

Karbon 700 Product Manual

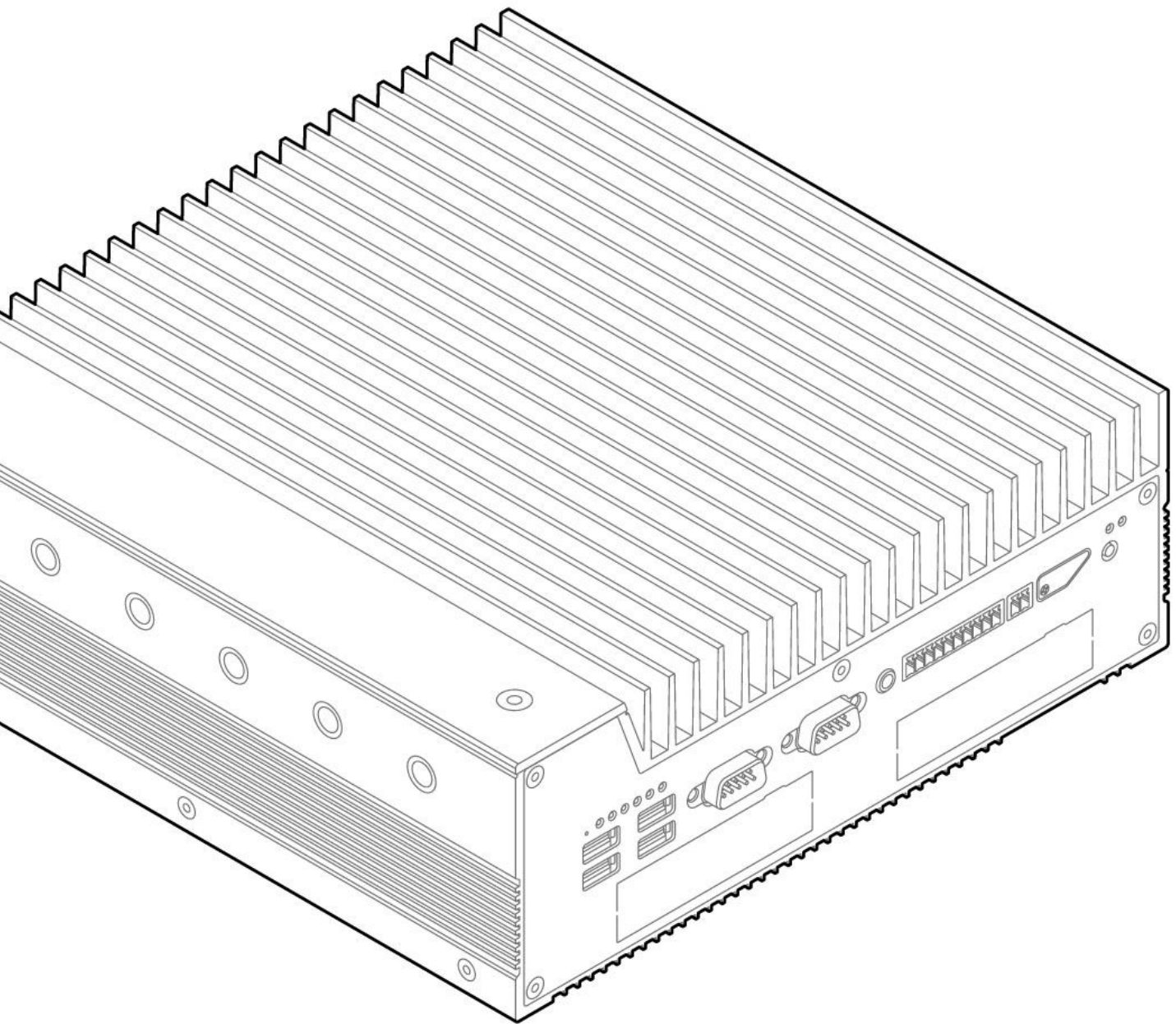

Revision History

Revision History	Date
First release of Karbon 700 manual	08/22/2019
Added ModBay LAN and PoE details to section 2.7	11/25/2019
Added DIN Rail details to section 3.3	08/19/2020
Updated DIO Illustration section 2.2	01/31/2021

1 - System Overview	5
1.1 - Accessories	5
1.2 - Product Specifications	6
1.3 - Exterior Features and Dimensions	8
1.3.1 - Front I/O	8
1.3.2 - Back I/O	8
1.3.3 - Karbon 700 Dimensions (K700-SE)	9
1.3.4 - Karbon 700 Dimensions with PCIe Expansion (K700-X2)	9
1.4 - Motherboard Overview	10
1.4.1 - System Block Diagram	10
1.4.2 - Motherboard Features	11
2 - I/O Definitions	13
2.1 - Serial Ports	13
2.2 - DIO	14
2.2.1 - DIO Connection Diagram	15
2.3 - Remote Power Switch	15
2.4 - LEDs	16
2.5 - Automotive Ignition Power Sensing (IGN)	17
2.6 - CAN Bus	17
2.6.1 - CAN Bus Connection Diagram	18
2.7 - LAN	18
3 - Mounting Instructions	19
3.1 - Wall Mount	19
3.2 - Wall Mount with Vibration Isolation	20

3.3 - DIN Rail Mount	21
4 - Microcontroller	22
4.1 - Overview	22
5 - Power Management	23
5.1 - Wake-Up Events	23
5.2 - Protection Circuitry	23
6 - Test Reports	24
6.1 - ISO 7637-2 and ISO 16750-2 Summary	24
6.1.1 - Electrical Supply/Load Voltage Drop Data	24
6.1.2 - Paragraph 4.11 Voltage Withstand Test Results	25
6.2 - Electrical Supply/Load Disturbance Data	25
6.2.1 - Paragraph 4.7 Reverse Voltage Test Results	25
6.2.2 - Paragraph 4.9 Open Circuit Test Results	25
6.2.3 - Paragraph 4.10 Open Circuit Test Results	26
6.2.4 - Paragraph 4.12 Open Circuit Test Results	26
6.3 - Conducted Transient Data	26
6.4 - EN 50121-3-2 Summary	27
6.4.1 - ESD Immunity Data	27
6.4.2 - Radiated Immunity Data	27
6.4.3 - Electrical Fast Transient Immunity Data	27
6.4.4 - Surge Immunity Data	27
6.4.5 - Conducted Immunity Data	27

1 - System Overview

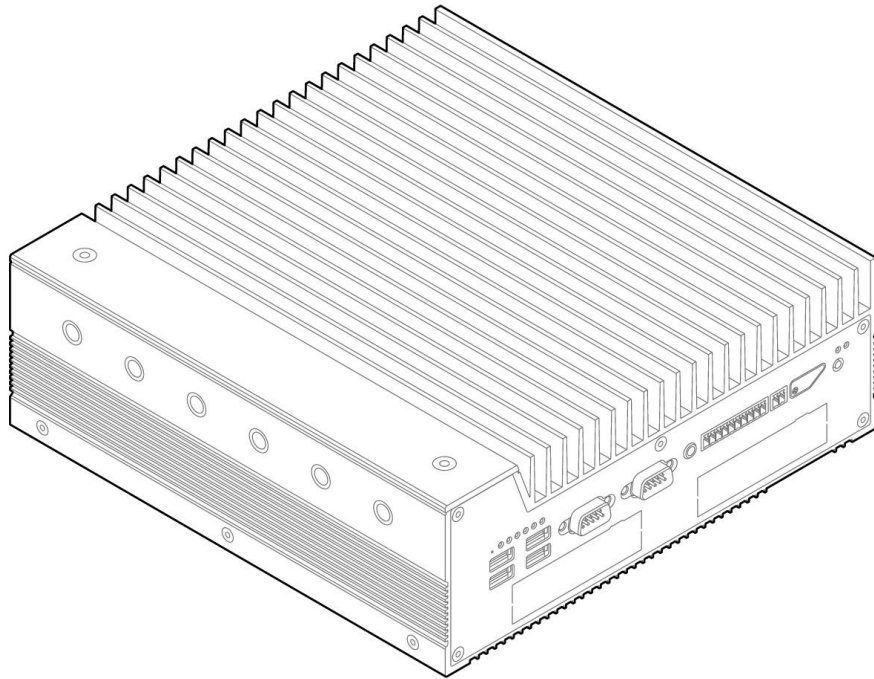

1.1 - Accessories

- 5-pin Power Terminal Block Connector (Dinkle PN: 2ESDVM-05P)
- 2-pin Remote Switch Terminal Block Connector (Dinkle PN: EC350V-02P)
- 3-pin CAN bus Terminal Block Connector (Dinkle PN: EC350V-03P)
- 10-pin DIO Terminal Block Connector (Dinkle PN: EC350V-10P)
- 5-pin Terminal Block to 6-pin Molex Adapter (OnLogic PN: CBP133)
- SATA Power and Data Cables If Not Installed (OnLogic PN: CBD123)

If you purchased additional items such as mounting brackets, power supplies or antennas, they will be located in the system box or within the outer shipping carton.







All drivers and product guides can be found on the corresponding product page. For more information on accessories and additional features, visit the Karbon 700 pages at:

US: <https://www.onlogic.com/k700-se/>
<https://www.onlogic.com/k700-x2/>

EU: <https://www.onlogic.com/eu-en/k700-se/>
<https://www.onlogic.com/eu-en/k700-x2/>

1.2 - Product Specifications

	Karbon 700 Series
Processor	Intel 8th Gen Coffee Lake & 9th Gen Coffee Lake Refresh LGA1151 Celeron, Pentium, Core & Xeon E up to 80W
Memory	2 DDR4-2666 SO-DIMM up to 64GB total (non-ECC or ECC)
Chipset	Intel C246
Integrated Graphics	Intel UHD Graphics 610/630
Front I/O	1 Power button 4 USB 3.1 Gen 1 Type A 2 Serial RS-232/422/485 1 3.5 mm audio jack (mic-in, stereo out) 8-bit isolated DIO (4-in, 4-out) 8 Status LEDs 2-pin Remote switch 1 Mini-SIM slot (2FF) 2 Hot-swap drive bays (optional)
Back I/O	5-pin Power input 3 Full-size DisplayPort 1.2 supporting DP++ and HDMI 1.4 3 Gb LAN (2 Gb Mode A PoE optional) 2 USB 3.1 Gen 1 Type A 2 ModBay™ expansion slots 3-pin CAN bus 2.0B 1 External fan connector
Expansion & Storage	1 M.2 2280 M-key (PCIe x4, SATA) 1 M.2 2230/60/80 M-key (PCIe x2) 1 M.2 2230 E-key (PCIe x1, USB 2.0) 2 Full-length mPCIe (1 duplexed with mSATA) 2 2.5" SATA SSD/HDD drives (hot-swap optional) 1 PCIe x16 <i>Max. PCIe dimensions: 211 x 129 x 41 mm (8.31 x 5.08 x 1.61 in)</i>
Special Features	OnLogic Microcontroller (MCU) Automotive Ignition Power Sensing SuperCap backup for RTC battery Optional TPM 2.0 module (Nuvoton NPCT750)
Operating Systems	Windows 10, Ubuntu 18.04
LAN Controllers	1 Intel I219-LM with AMT support 2 Intel I210-AT
Voltage Input	9~48 VDC with 5-pin terminal block
Dimensions	240 x 242 x 82 mm (9.45 x 9.53 x 3.23 in)
Mounting	Wall/surface (bottom) Wall/surface with Vibration Isolation (bottom)

Temperature	<p>Operating Temperature: -40°C ~ 70°C (35W TDP CPU) -40°C ~ 50°C (60W TDP CPU) -40°C ~ 40°C (80W TDP CPU)</p> <p>Storage Temperature: -40°C ~ 85°C</p>
Humidity	<p>Operating Humidity: 10~95% relative Storage Humidity: 0~95% relative</p>
Shock & Vibration	<p>Shock: Tested according to IEC 60068-2-27 and MIL-STD-810G Vibration: Tested according to IEC 60068-2-64 and MIL-STD-810G</p>
Certifications	<div style="display: flex; flex-direction: column; align-items: flex-start;"> <div style="display: flex; align-items: center; margin-bottom: 10px;">  <p>FCC 47 CFR Part 15</p> </div> <div style="display: flex; align-items: center; margin-bottom: 10px;">  <p>Low-Voltage (2014/35/EU) Electromagnetic Compatibility (2014/30/EU) Radio Equipment (2014/53/EU) - Only applicable for configurations with wireless transmitters EN 55032 EN 55035</p> </div> <div style="display: flex; align-items: center; margin-bottom: 10px;">  <p>RoHS 3 (2015/863/EU)</p> </div> <div style="display: flex; align-items: center; margin-bottom: 10px;">  <p>WEEE Directive (2012/19/EU)</p> </div> <div style="display: flex; align-items: center; margin-bottom: 10px;">  <p>IEC 60068-2-27 IEC 60068-2-64 MIL-STD-810G</p> </div> <div style="display: flex; align-items: center; margin-bottom: 10px;">  <p>Power Immunity According to E-Mark 7637-2 & 16750-2</p> </div> <div style="display: flex; align-items: center;">  <p>EN 50121</p> </div> </div>

1.3 - Exterior Features and Dimensions

1.3.1 - Front I/O

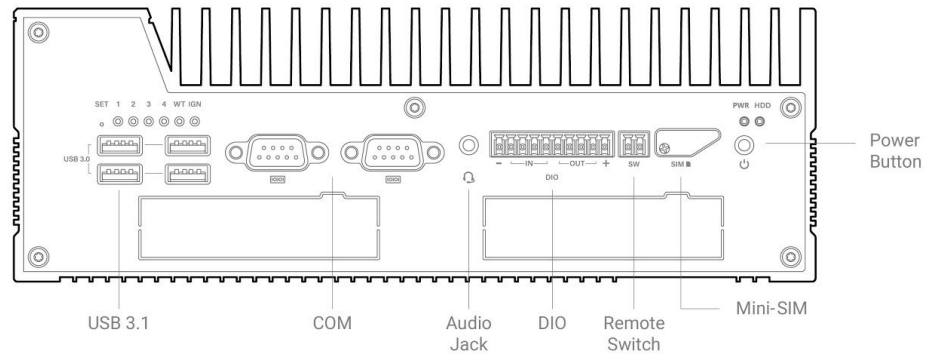

1.3.2 - Back I/O

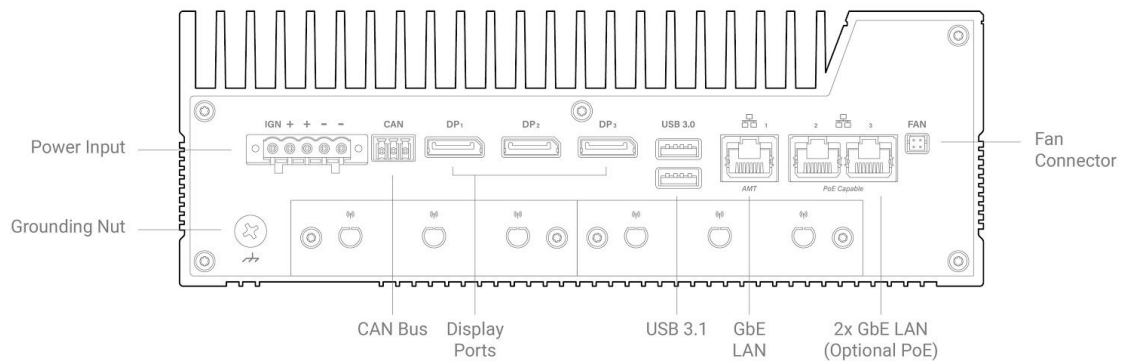

1.3.3 - Karbon 700 Dimensions (K700-SE)

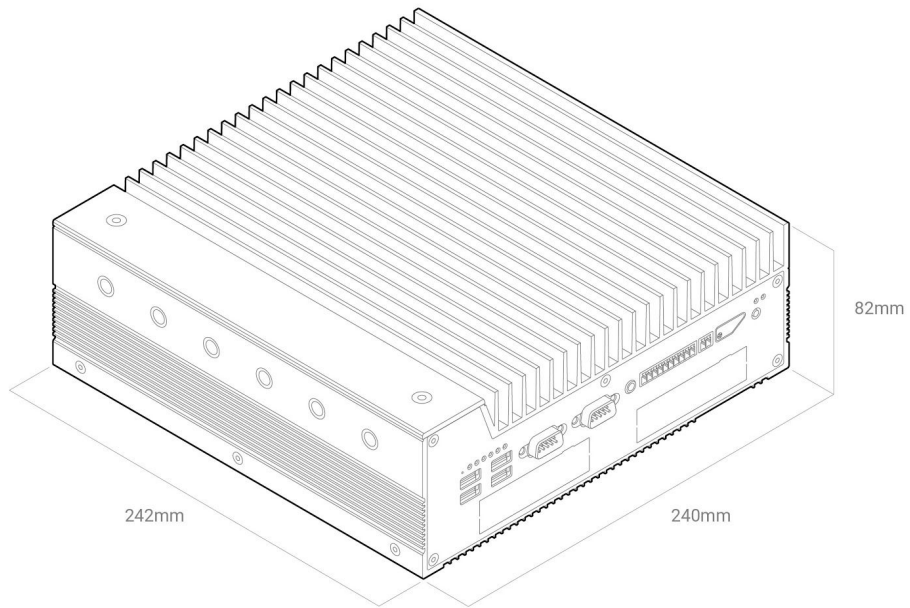

1.3.4 - Karbon 700 Dimensions with PCIe Expansion (K700-X2)

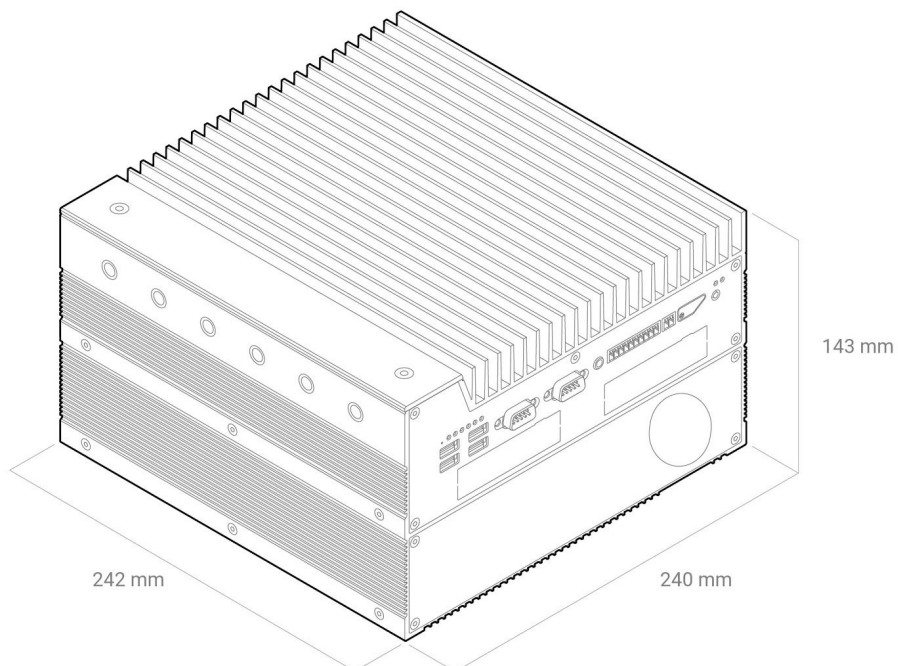

1.4 - Motherboard Overview

1.4.1 - System Block Diagram

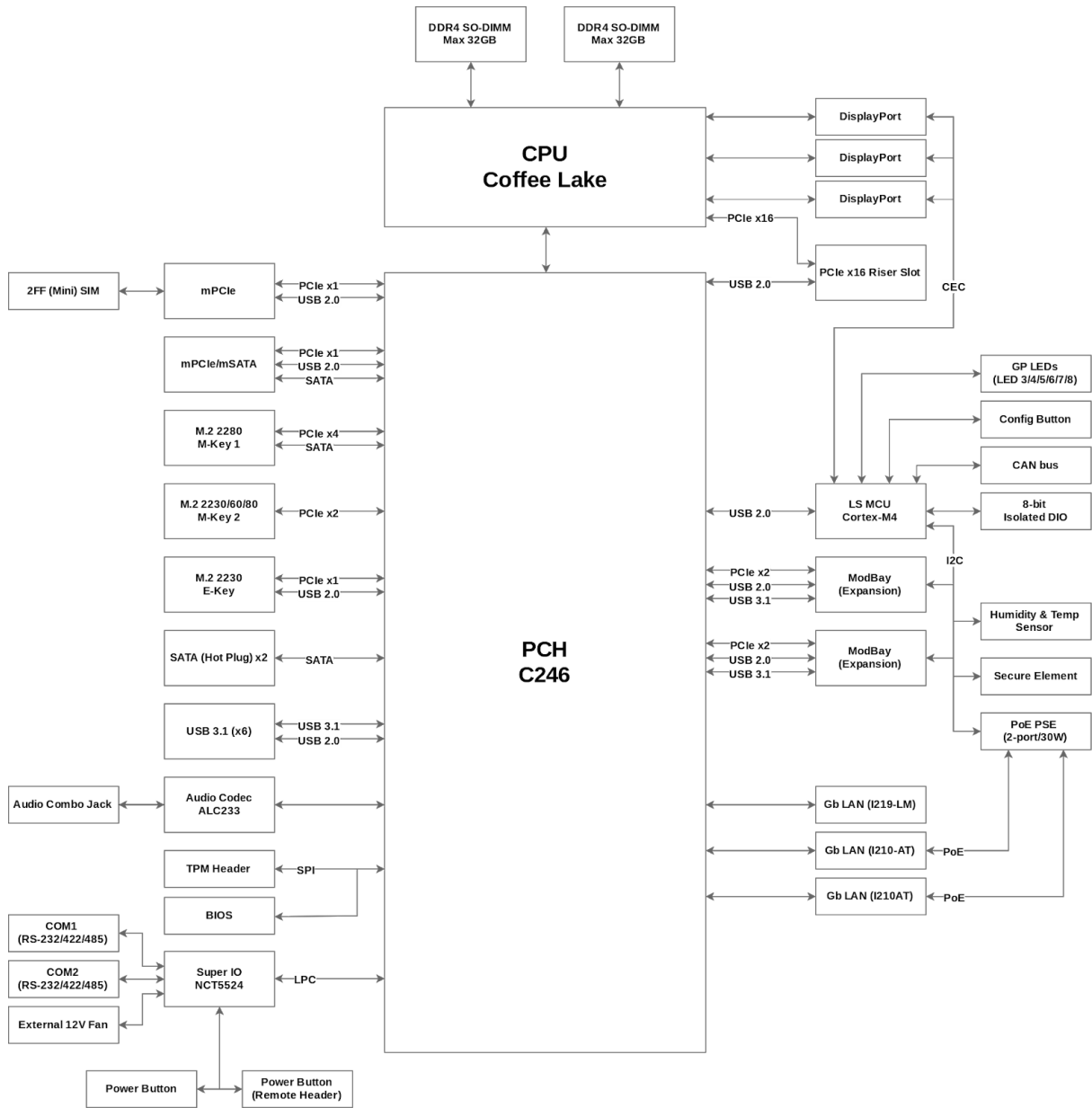

1.4.2 - Motherboard Features

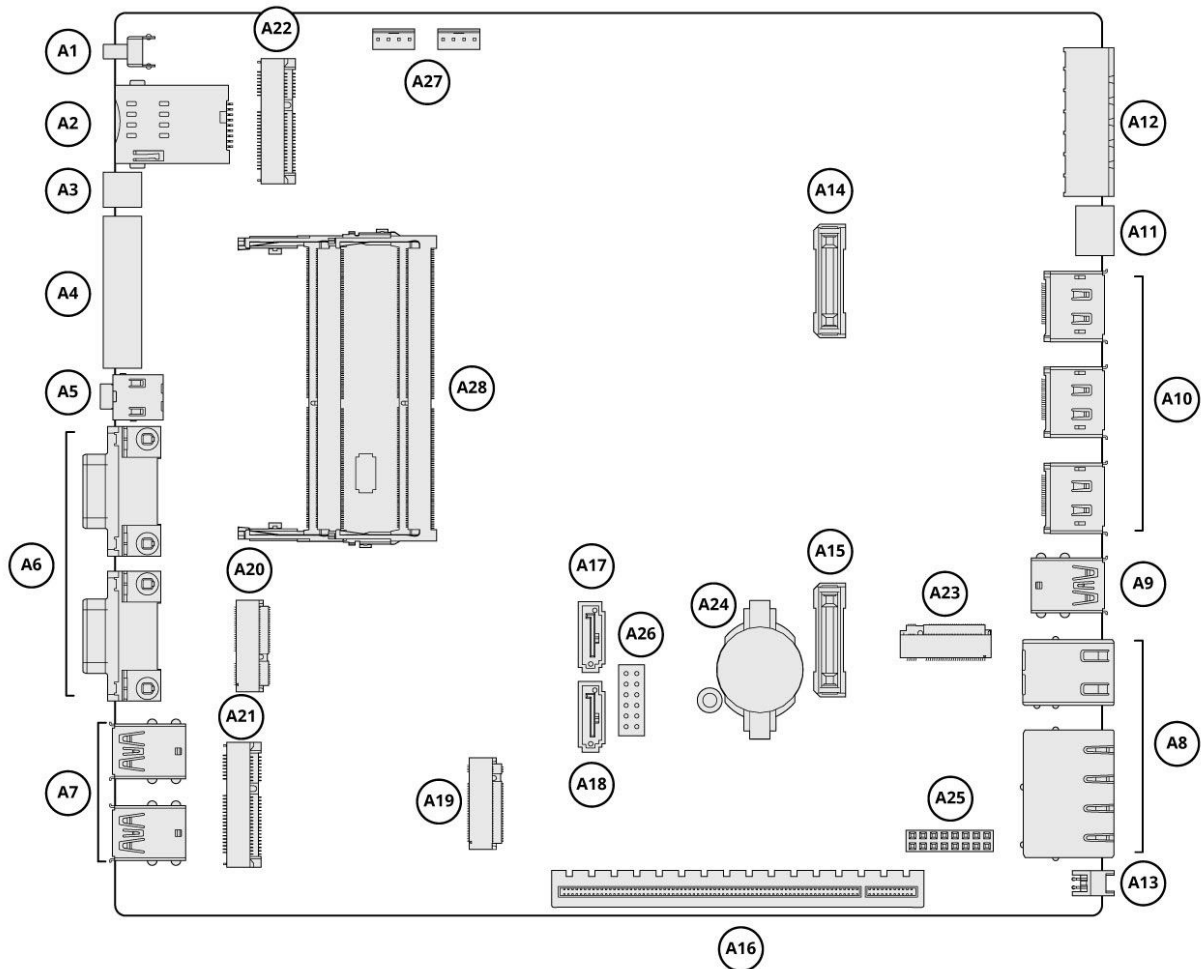

Item	Function Description
A1	Power button
A2	SIM card holder
A3	Remote switch
A4	8-bit isolated DIO (10 pins, 4-in, 4-out)
A5	3.5 mm combo audio connector
A6	COM RS-232/422/485 ports
A7	USB 3.1 Gen 1 Type A
A8	3 RJ45 GbE LAN connector (2 PoE optional with A25 module)
A9	USB 3.1 Gen 1 Type A

A10	Full-size DisplayPort with CEC support
A11	3-pin CAN bus
A12	5-pin power input with ignition sense
A13	External fan connector
A14	ModBay™ connector 1
A15	ModBay™ connector 2
A16	PCIe riser slot (x16 lanes)
A17	SATA 1
A18	SATA 2
A19	M.2 2230/60/80 M-key
A20	M.2 2230 E-key
A21	mPCIe/mSATA
A22	mPCIe
A23	M.2 2280 M-key
A24	RTC backup battery
A25	Onboard PoE module header
A26	TPM module header
A27	2 SATA power
A28	2 SO-DIMM memory slots

2 - I/O Definitions

2.1 - Serial Ports

The serial port mode and voltage between Off/5V/12V on Pin 9 on Karbon 700 can be selected in the BIOS configuration. The serial ports support RS-232, RS-422, and RS-485 configurations. Refer to the BIOS manual for configuration instructions.

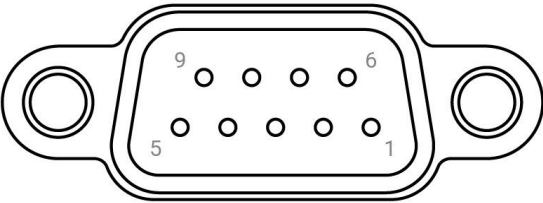
	Pin	RS-232	RS-422	RS-485
	1	DCD	TX-	TX-/RX-
	2	RX	TX+	TX+/RX+
	3	TX	RX+	NC
	4	DTR	RX-	NC
	5	GND	NC	NC
	6	DSR	NC	NC
	7	RTS	NC	NC
	8	CTS	NC	NC
	9	RI/PWR	NC/PWR	NC/PWR

NC = Not Connected

2.2 - DIO

The Karbon 700 Digital Input Output (DIO) or General Purpose Input Output (GPIO) terminals are optically isolated. This means that the terminal is separated from other motherboard features for protection. The DIO terminal requires external power from a 5~48VDC source through Pin 1 with GND to Pin 10 in order to function.

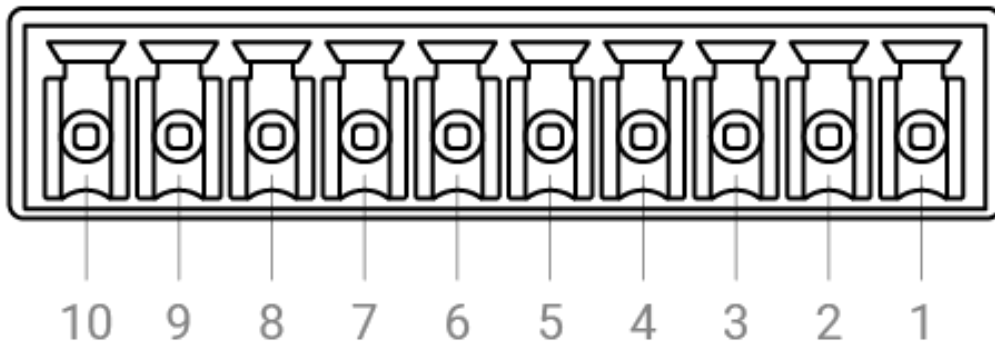

Pin 10	Pin 9	Pin 8	Pin 7	Pin 6	Pin 5	Pin 4	Pin 3	Pin 2	Pin 1
GND	In 4	In 3	In 2	In 1	Out 4	Out 3	Out 2	Out 1	Power

2.2.1 - DIO Connection Diagram

Karbon 700

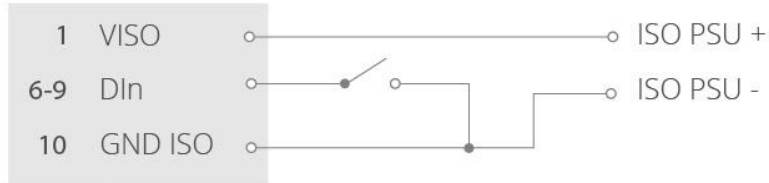

Karbon 700

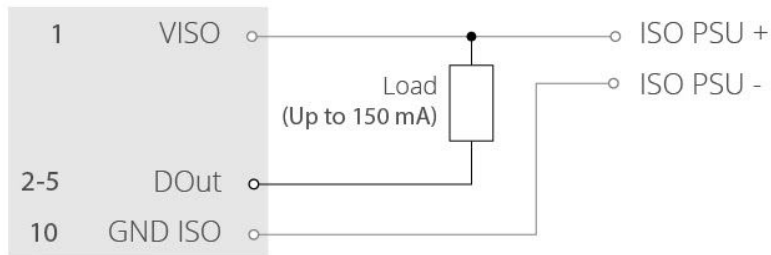

Karbon 700

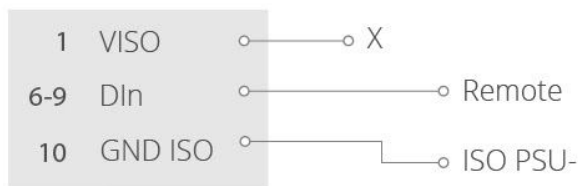

The Isolated Power Supply (ISO PSU) can be a voltage source from 5V-48V to interface with external digital IO. The max power draw from the supply should not exceed 0.6A under normal operating conditions. Individual DOut pins will be damaged by a load in excess of 150mA. The ISO PSU can only be a DC Limited Power Source (LPS) power supply.

2.3 - Remote Power Switch

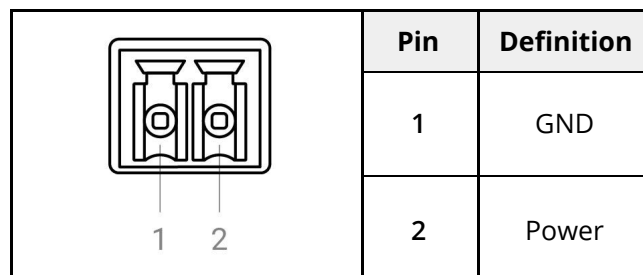

Mating power switch cables should be a twisted-pair wire with floating shield to assure proper immunity to EMI/RFI. It is recommended to keep wires at less than 3 meters in length. Switches should be momentary contact type only.

2.4 - LEDs

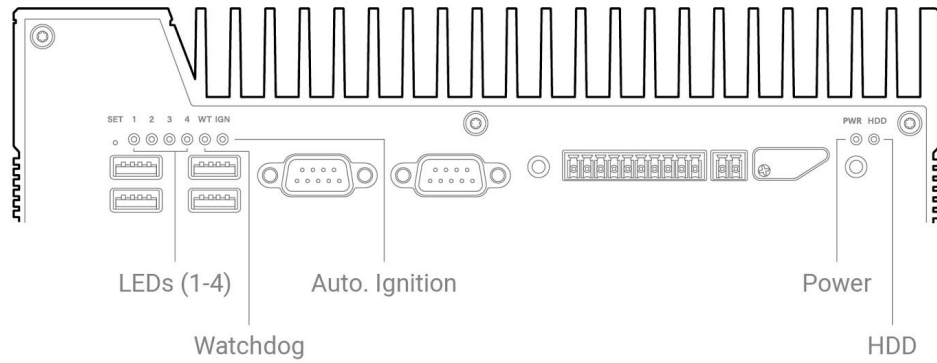

LED	On	Off	Blink	Pulse
HDD	-	-	Internal storage drive activity	-
Power	Device is on	Device is off	Device is asleep	-
Automotive Ignition	Ignition input to device is on	Ignition input to device is off	-	-
Watchdog	MCU is not functioning normally	MCU is not functioning normally	Firmware bootloader is active	MCU is functioning normally
LEDs 1-4	Currently selected user mode	-	-	-

2.5 - Automotive Ignition Power Sensing (IGN)

The Karbon 700 5-pin power input terminal offers automotive ignition sensing. The ignition sensing timing for power on and off delays can be modified through OnLogic's microcontroller (MCU) using serial commands. These commands allow setting the delay on startup after ignition is detected, the delay until soft and hard shutdown when ignition is lost, and enabling/disabling ignition sensing. For more information on ignition power sensing, and instructions on using these serial commands from Windows or Linux, visit [OnLogic's tech support site on the Karbon series ignition sensing](#).

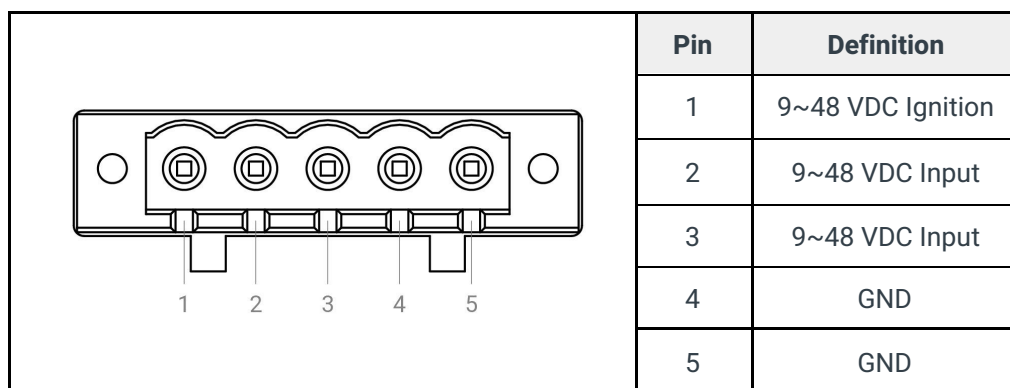
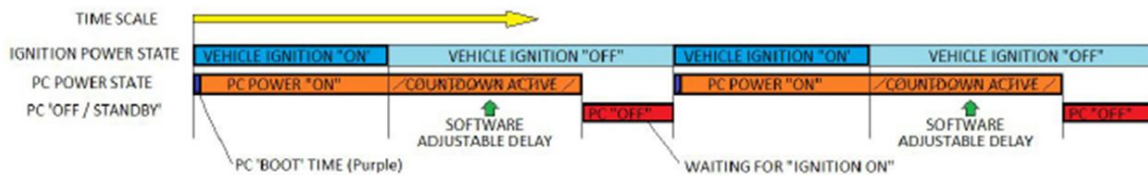

The system should always be used with the supplied 5-pin terminal block. The total system power draw and input voltage will determine whether only two of the power pins can be used. Configurations with high wattage CPUs (65W or more), PoE ModBay cards, or GPU expansion must use all 4 power pins. Low voltage supplies (9~12V) should also use all 4 power pins. If only two of the input pins are used, it is recommended to use a jumper between the populated and open connection.

2.6 - CAN Bus

See Section 4 for information on how to drive the CAN bus.

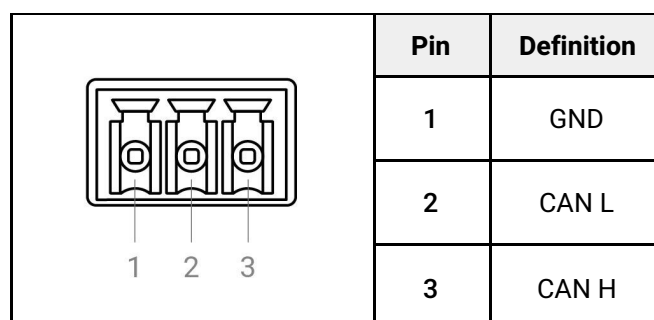

2.6.1 - CAN Bus Connection Diagram

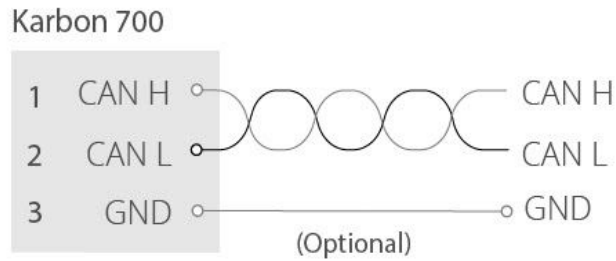

2.7 - LAN

The Karbon 700 provides three GbE LAN ports. Two of these LAN ports have an optional PoE function using an optional onboard module. When the PoE module is installed, the two PoE ports will provide up to 32W of combined power. This power output is enough to support a single port up to 25.5W (IEEE 802.3at), two ports up to 15.4W each (IEEE 802.3af), or two ports with a combined draw up to 32W (e.g. 7W and 25W). PoE is enabled by adding the optional PoE Expansion card.

	LED	Color	State	Condition
<p>Link LED (Green)</p> <p>Speed LED (Green/Yellow)</p>	Link	-	Off	LAN link is not established
		Green	On	LAN link is established
			Blinking	LAN activity occurring
Speed	-	Off	10 Mb/s data rate	
	Green	On	100 Mb/s data rate	
	Yellow	On	1000 Mb/s data rate	

The K700 also supports LAN expansion using optional ModBay cards. ModBay cards can be configured to add up to eight additional LAN or four additional PoE ports. The ModBay LAN and PoE expansion cards provide GbE LAN ports each using an Intel I210-AT controller. ModBay PoE power output depends on voltage input, total system power draw, and operating temperature. The ModBay PoE card supports up to 30W per port at 70°C with a total output of 110~120W using 48V input, 105~120W using 24V, 75~90W using 12V, and 60W using 9V. The PoE power output range for each voltage input is dependent on system configuration and total power draw.

3 - Mounting Instructions

3.1 - Wall Mount

Step 1: Attach wall mounting brackets to the chassis using:

Screw type: M4X0.7 T10 TORX 120°

Length: 10 mm

Step 2: Mark and prepare holes on the surface for mounting

Step 3: Fasten system to surface. The mounting bracket systems are required to secure 3x the hanging weight of the computer system. The mating substrate must be capable of maintaining the same rating.

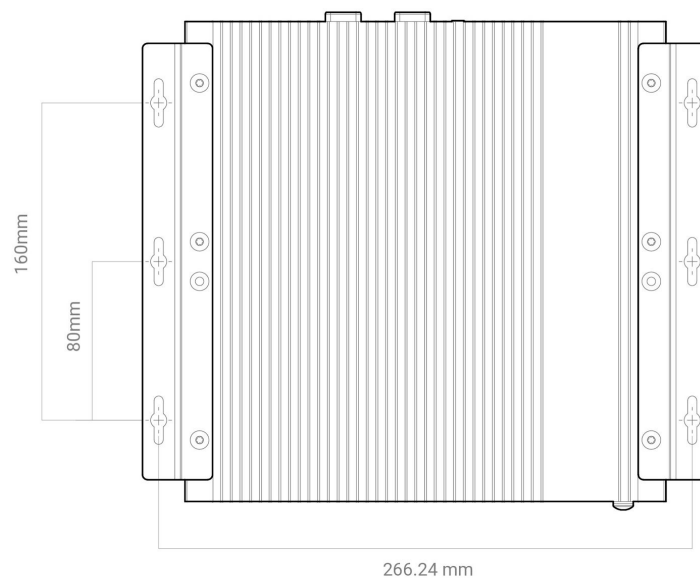
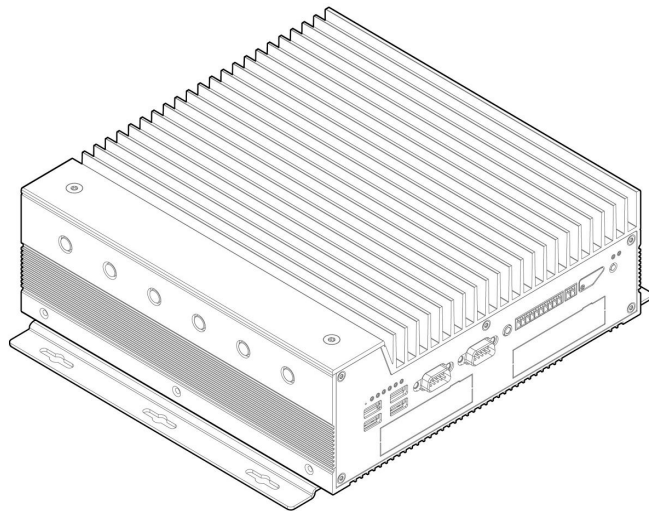

3.2 - Wall Mount with Vibration Isolation

Step 1: Attach wall mounting brackets to the chassis using:

Screw type: M4X0.7 T10 TORX 120°

Length: 10 mm

Step 2: Mark and prepare holes on the surface for mounting

Step 3: Fasten system to surface

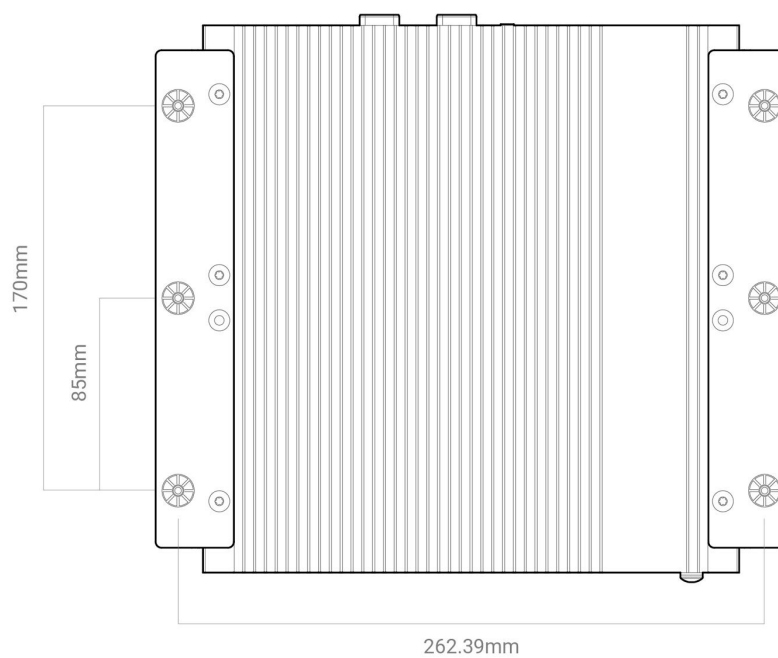
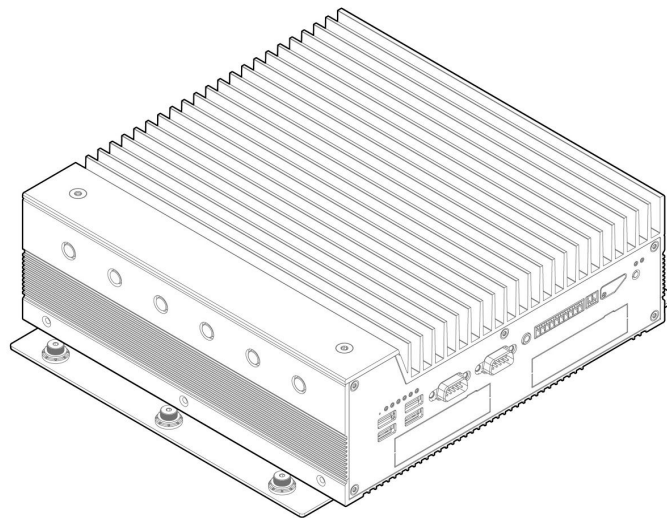
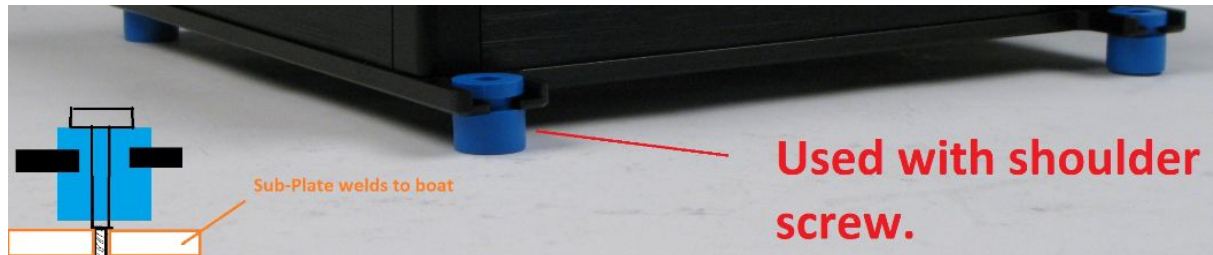

3.3 - DIN Rail Mount

Step 1: Attach DIN-compatible wall mounting brackets to the chassis using:

Screw type: M4X0.7 T10 TORX 120°

Length: 10 mm

Step 2: Attach DIN Rail clips to brackets using:

Screw type: M3X0.5 P2 120°

Step 3: Clip system to the DIN Rail

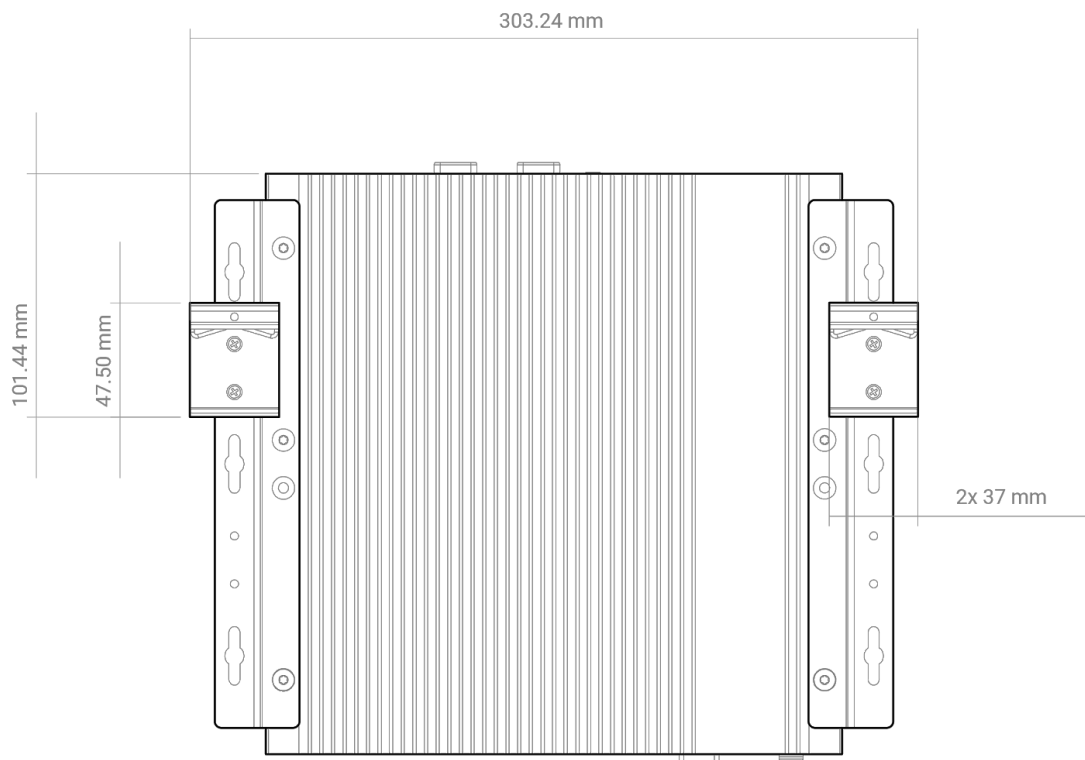
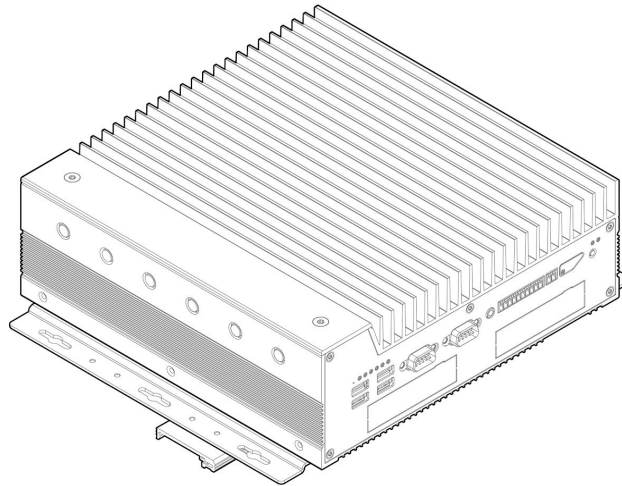

4 - Microcontroller

4.1 - Overview

The microcontroller on Karbon 700 controls several systems, including:

- Automotive ignition power sensing
- CAN bus
- DIO
- Status LEDs
- Power management and wake-up
- DisplayPort CEC and persistent EDID
- Input voltage monitoring

A segment is exposed for user control via two serial ports. By reading and writing to these serial ports, the user can send and receive CAN messages, read/set the DIO state, and select from a number of configuration options. One port is dedicated to Karbon 700's CAN bus, while the other doubles as a serial terminal and the DIO interface. Any configuration settings may be saved to non-volatile memory which means the MCU settings will be retained during a long power-off.

The serial interfaces can be controlled through Pykarbon, the karbon series' very own MCU interface tool. To learn more about how to use the Karbon series MCU and Pykarbon interface tools, visit our [Karbon Series technical support site](#) for a complete overview of articles.

View the following articles for specific information:

[Introducing the Pykarbon Module: Karbon Series Interface Tool](#): for information on the Pykarbon module and how to set up the Pykarbon module to configure your system.

[Karbon Series - Using the Serial Interface](#): for information regarding voltage settings, timing settings, and sending commands to the serial interface to configure your system.

[Karbon Series - CAN Bus FAQ](#): for information regarding the CAN Bus and how to configure it.

The Pykarbon module is designed to be a simple and easy tool for configuring your system to meet your needs and applications. Visit [OnLogic's Pykarbon GitHub page](#) for specific information regarding using the interface tool.

5 - Power Management

5.1 - Wake-Up Events

Karbon 700 supports multiple power states. The wake-up events can be configured in the MCU and BIOS. This section describes the power management functions you can perform and gives information on protection circuitry for power adapters.

Wake-Up Event	From ACPI State	Comments
Power Button	VR-Disabled, S5, S3	
Ignition	VR-Disabled, S5, S3	Must be enabled in MCU
Digital Input	S5, S3	Must be enabled in MCU
LAN	S5, S3	Must be enabled in BIOS
USB	S3	
RTC Alarm	S5, S3	Must be enabled in BIOS

5.2 - Protection Circuitry

Parameter	Value
Nominal operating voltage (Rated DC value of input)	9~48V
Undervoltage protection trip DC level (system turns off)	7.6V
Overvoltage protection trip DC level (system turns off)	52.5V
Maximum safe DC voltage (system not damaged)	56V
Minimum safe reverse voltage (system not damaged)	-36V
Ignition pin safe working voltage (system not damaged)	56V

These DC levels specified are the absolute max values for the pins for function and safety of the system. The protection circuitry allows for brief transient voltages above these levels without the system turning off.

6 - Test Reports

6.1 - ISO 7637-2 and ISO 16750-2 Summary

The OnLogic, Inc. Model Karbon 700 PC meets ISO 7637-2 and ISO 16750-2 requirements for conducted transients and supply/load disturbance. Sections IX through XI reference measurement procedures of VIII-1 through -7 in accordance with performance criteria described in Section V for type acceptance and per the manufacturer's test plan.

6.1.1 - Electrical Supply/Load Voltage Drop Data

The table below describes the results of the electrical load test. The system does not exhibit susceptibility to voltage drop profiles and pulses delivered directly to power lines.

“A” result = No effect on EUT.

“C” result = Operator intervention required.

“C” is an acceptable result for the test of 4.5 per the standard. The unit recovers and operates normally once the voltage returns to specified levels per the datasheet (Operates at >5 VDC).

ISO 16750-2 Paragraph	Voltage	Application Port	Duration	Cycle/PRT	Spec.	Result
4.3	36V	Power Entry	60 m	1	A	A
4.4	10V 50Hz - 25 kHz	Power Entry	120 s	5	A	A
4.5	9V to 0V 0V to 9V	Power Entry	1080 ms 1080 ms	1	C	C
4.6.1	9V to 9V	Power Entry	100 ms @ 10 s	1	B	A
4.6.2	9V to 0V .45V steps	Power Entry	300 s	1	C	A
4.6.3	24V to 10V with 2V AC profile	Power Entry	1150 ms	10	A	A
4.6.4.2.2	151V	Power Entry	100 ms	10	A	A
4.6.4.2.3	151V/58V	Power Entry	100 ms	5	C	A

6.1.2 - Paragraph 4.11 Voltage Withstand Test Results

500 VDC for 60 s. > 10 mA or catastrophic event to fail.

Test Point	Notes	Current (mA)
Main Input	Class C	3.01

6.2 - Electrical Supply/Load Disturbance Data

The tables below describe the results from the ISO 16750-2 electrical load tests. The system

does not exhibit susceptibility to disturbances delivered directly to power lines.

6.2.1 - Paragraph 4.7 Reverse Voltage Test Results

@ 28 VDC for 60 s.

Test Point	Notes	Current (mA)
Main Input	Class A	0

6.2.2 - Paragraph 4.9 Open Circuit Test Results

@ 0 VDC for 10 s.

Test Point	Notes	Current (mA)
Main Input Single Lead	Class C	0
Main Input Both Leads	Class C	0

6.2.3 - Paragraph 4.10 Open Circuit Test Results

@ 32 VDC for 60 s.

Test Point	Notes	Current (mA)
Main Input	Outputs Active, Class C	0
Main Input	Outputs Inactive, Class C	0
Main Input	Supply Inactive, Class C	0

6.2.4 - Paragraph 4.12 Open Circuit Test Results

@ 500 VDC, <10 MΩ to fail.

Test Point	Notes	Resistance (MΩ)
Main Input	Class C	>1000 MΩ

6.3 - Conducted Transient Data

The table below describes the results of the transient test. The system does not exhibit susceptibility to conducted transients delivered directly to power lines.

"A" result = No effect on EUT.

Pulse	Voltage V	Application Port	Duration	Cycle/PRT	Spec.	Result
1	-450	Power Entry	500	500 ms	A	A
2a	+55	Power Entry	500	200 ms	A	A
2b	+20	Power Entry	10	500 ms	A	A
3a	-220	Power Entry	1 hour	100 ms	A	A
3b	+220	Power Entry	1 hour	100 ms	A	A

6.4 - EN 50121-3-2 Summary

The Karbon 700 PC complies with the EN 61000-6-4 radiated and conducted

emissions limits as tailored by EN 50121-3-2. The unit passes EN 50121-3-2, Table 5 levels for ESD and radiated immunity. The unit also passes EN 50121-3-2, Tables 3 & 4 levels for EFT, conducted, and surge immunity.

All EN 50121-3-2 testing on the Karbon 700 PC was performed without the use of an AC-DC external power adapter. Instead, a direct DC power input was used.

6.4.1 - ESD Immunity Data

The unit does not exhibit susceptibility to 4-kV and 6-kV contact/8-kV air discharges applied singly or repetitively, and directly or indirectly. The relative humidity during unit testing was measured to be between 30% and 60%. The Karbon 700 PC was unaffected during testing.

6.4.2 - Radiated Immunity Data

The system does not exhibit susceptibility to 20/10/5/3-V/m radiated electric fields, amplitude modulated at 1000 Hz, 80%, from 80 MHz to 6 GHz. Frequencies listed are samples and spots. The Karbon 700 PC was unaffected during testing.

6.4.3 - Electrical Fast Transient Immunity Data

The system does not exhibit susceptibility to 0.5-kV/1-kV/2-kV electrical fast transients, delivered in 5-kHz bursts to power lines. "A" result = No effect on EUT.

The system does not exhibit susceptibility 0.5-kV/1-kV/2-kV electrical fast transients, delivered in 5-kHz bursts to signal lines. The Karbon 700 PC was unaffected during testing.

6.4.4 - Surge Immunity Data

The system does not exhibit susceptibility to 1-kV line-to-line/2-kV line-to-ground, 1.2/50us-combination wave surges delivered directly or by 90°- and 270°-phase synchronizations. The Karbon 700 PC was unaffected during testing.

6.4.5 - Conducted Immunity Data

The system does not exhibit susceptibility to 3/1-V conducted signals applied, using the injection probe, to the signal lines from 150 kHz to 80 MHz. Frequencies listed are samples; dwell >EUT response time. The Karbon 700 PC was unaffected during testing.