

ML100G-51/52 Manual

Version 1



US Office

Phone: +1 802 861 2300
Email: info@onlogic.com
www.onlogic.com

EU Office

Phone: +31 85 2733760
Email: info@onlogic.eu
www.onlogic.com

ML100G-51/52 Manual

About OnLogic	3
Contact Information	3
Regulatory Compliance and Safety Information	4
Safe Use and Installation Instructions	4
1 - What's In The Box	7
2 - System Overview	8
2.1 - System Diagram	8
2.2 - System Specifications	9
2.3 - Mounting Hole Pattern	10
2.4 - Mounting Guide	11
3 - Motherboard Overview	12
3.1 - Jumpers and Headers Guide	13
3.2 - Configuring Jumpers	14
3.3 - Onboard Headers	15



About OnLogic

OnLogic is powering innovation with highly configurable embedded and IoT computers engineered for reliability. Businesses worldwide depend on our solutions to operate in the toughest environments while tapping into the evolving Industrial Internet of Things.

This guide will introduce you to the ML100G-51 and ML100G-52 industrial fanless computers and system specifications. For technical questions or support, please reach out via our contact information below.

You have a lot of choices when choosing computer hardware. The OnLogic Team wants to thank you for trusting our components to meet your application needs. The ML100G-51/52 is the result of input from partners like you. We've worked hard to create a system that meets the varied needs of industrial and IoT computing and we've manufactured this system under our strict quality assurance and immunity standards to serve you best. If you have any concerns about the quality or performance of this product, please contact us directly or visit our support pages at US: <https://www.onlogic.com/company/support/> or EU: <https://www.onlogic.com/eu-en/company/support/>.

Contact Information

OnLogic Global

35 Thompson Street,
South Burlington, VT 05403
USA

+1 802 861 2300
info@onlogic.com

OnLogic Europe

De Boedingen 39
4906 BA Oosterhout
The Netherlands

+31 88 5200 700
info@onlogic.eu

Revision History

Revision History	Date
Release of ML100G-51/52 manual	7/31/2019

Regulatory Compliance and Safety Information

Regarding equipment: Industrial Fanless PC model(s): xxxxxML100G-51xxxxx and xxxxxML100G-52xxxxx (where x is any alphanumeric character, "-" or blank designating configuration differences)

Safe Use and Installation Instructions

1. Do not open or modify the device. The device uses components that comply with FCC and CE regulations. Modification of the device may void these certifications.
2. Install the device securely. Be careful handling the device to prevent injury and do not drop.
3. Wall or ceiling mounting device requires use of a mounting plate or bracket. Plate or bracket must be of metal construction and have a minimum thickness of 1mm.
4. Use M3x0.5mm Flat Head screws to attach mounting plate or mounting brackets to threaded holes on bottom or rear of chassis. Screws should be minimum length of 4mm. Add 1mm of screw length for every milimeter of additional thickness of plate or bracket beyond 1.5mm.
5. Ambient operational temperature must be between 0 °C to 40 °C, or with some configurations 0 °C to 50 °C , with a non-condensing relative humidity of 10-90%.
6. The device can be stored at temperatures between -40 °C to 85 °C.
7. Keep the device away from liquids and flammable materials.
8. Do not clean the device with liquids. The chassis can be cleaned with a cloth.
9. Allow at least 2 inches of space around all sides of the device for proper cooling. If device is mounted to vertical surface then recommended device orientation so that heatsink fins allow air to rise unobstructed. Alternative orientations may result in reduced operational temperature range.
10. This device is intended for indoor operation only.
11. Use UL Listed external power supply with rated output 12Vd.c., 5A min.
12. Install the device only with shielded network cables.
13. Service and repair of the device must be done by qualified service personnel. This includes, but is not limited to, replacement of the CMOS battery. Replacement CMOS battery must be of the same type as original.
14. Proper disposal of CMOS battery must comply with local governance.

 **WARNING:** There is danger of explosion if the CMOS battery is replaced incorrectly. Disposal of battery into fire or a hot oven, or mechanically crushing or cutting of a battery can result in an explosion.

Précautions et guide d'installation

1. Ne pas ouvrir ou modifier l'appareil. L'appareil utilise des composants conformes aux réglementations FCC et EC. La modification de l'appareil peut annuler ces certifications.
2. Installez l'appareil en toute sécurité. Soyez prudent lors de la manipulation de l'appareil pour éviter les blessures et ne pas faire tomber.
3. Le montage au mur ou au plafond nécessite l'utilisation d'une plaque de montage ou d'un support. La plaque ou le support doit être en métal et doit avoir une épaisseur minimale de 1 mm.
4. Utilisez des vis à tête plate M3x0,5mm pour fixer la plaque de montage ou les supports aux trous filetés situés au bas ou à l'arrière du châssis. Les vis doivent avoir une longueur minimale de 4 mm. Ajoutez 1 mm de longueur de vis pour chaque mm d'épaisseur supplémentaire de plaque ou de support dépassant 1,5 mm.
5. La température ambiante opérationnelle doit se situer entre 0 °C et 40 °C, ou pour certaines configurations, entre 0 °C et 50 °C avec une humidité relative sans condensation entre 10 et 90%.
6. La plage de températures de stockage doit être de -40 °C à 85 °C.
7. Gardez l'appareil à l'écart des liquides et des matières inflammables.
8. Ne nettoyez pas l'appareil avec des liquides. Le châssis peut être nettoyé avec un chiffon.
9. Laissez au moins 5 cm d'espace autour de tous les côtés de l'appareil pour un refroidissement correct. Si l'appareil est monté sur une surface verticale, l'orientation recommandée est telle que les ailettes du dissipateur de chaleur permettent à l'air de monter sans obstruction. Les orientations alternatives peuvent entraîner une réduction de la plage de température de fonctionnement.
10. Cet appareil est conçu uniquement pour une utilisation en intérieur.
11. Utilisez une alimentation externe listée UL avec une sortie nominale de 12Vd.c., 5A min.
12. Installez l'appareil uniquement avec des câbles réseau blindés.
13. L'entretien et la réparation de l'appareil doivent être effectués par du personnel qualifié. Cela inclut, sans toutefois s'y limiter, le remplacement de la batterie CMOS. La batterie CMOS de remplacement doit être du même type que l'originale.
14. La mise au rebut des batteries usagées doit être réalisée conformément aux réglementations environnementales.

 **WARNING: ATTENTION:** Risque d'explosion si la batterie est remplacée par une batterie de type incorrect. Les batterie doivent être recyclées dans la mesure du possible.

Declaration of Conformity

CE

in accordance with the following Directive(s):

Electromagnetic Compatibility (2014/30/EU)

Low-Voltage (2014/35/EU)

RoHS 2 (2011/65/EU)

Radio Equipment (2014/53/EU) - Only applicable for configurations with wireless transmitters

hereby declare that: Equipment: Industrial Fanless PC model(s): xxxxxML100G-51xxxx and xxxxxML100G-52xxxxx (where x is any alphanumeric character, "-" or blank designating configuration differences) is in conformity with the applicable requirements of the following documents:

- EN 55032:2015/AC:2016 Class A
- EN 55035:2017
- EN 61000-3-2:2014 Class D
- EN 61000-3-3:2013
- EN 61000-4-2:2009
- EN 61000-4-3:2006+A1:2008+A2:2010
- EN 61000-4-4:2012
- EN 61000-4-5:2014+A1:2017
- EN 61000-4-6:2014+AC:2015
- EN 61000-4-8:2010
- EN 61000-4-11:2004+A1:2017
- EN 62368-1:2014 / A11:2017
- EN 301 489-1 V2.2.0 (2017-03) Draft
- EN 301 489-17 V3.2.0 (2017-03) Draft

FCC

This device complies with part 15 of the FCC rules as a Class A device. Operation is subject to the following two conditions: (1) this device may not cause harmful interference and (2) this device must accept any interference received, including interference that may cause undesired operation.

ISED (Innovation, Science and Economic Development Canada)

This device complies with Industry Canada license-exempt RSS standard(s). Operation is subject to the following two conditions: (1) this device may not cause interference, and (2) this device must accept any interference, including interference that may cause undesired operation of the device.

Le présent appareil est conforme aux CNR d'Industrie Canada applicables aux appareils radio exempts de licence. L'exploitation est autorisée aux deux conditions suivantes : (1) l'appareil ne doit pas produire de brouillage, et (2) l'utilisateur de l'appareil doit accepter tout brouillage radioélectrique subi, même si le brouillage est susceptible d'en compromettre le fonctionnement.

1 - What's In The Box

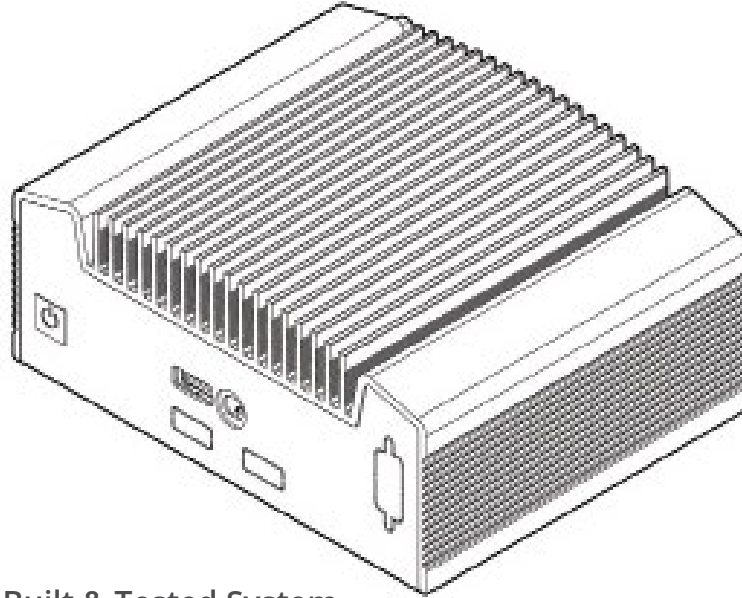

ML100G-51/52 Built & Tested System



Any Selected Accessories

If you purchased additional items such as specific mounting brackets, power supplies or antennas, they will be located in the system box or within the outer shipping carton.

All drivers and product guides can be found on the corresponding product page at:

US: <https://www.onlogic.com/ml100g-51/> and
<https://www.onlogic.com/ml100g-52/>

EU: <https://www.onlogic.com/eu-en/ml100g-51/> and
<https://www.onlogic.com/eu-en/ml100g-52/>.

2 - System Overview

2.1 - System Diagram

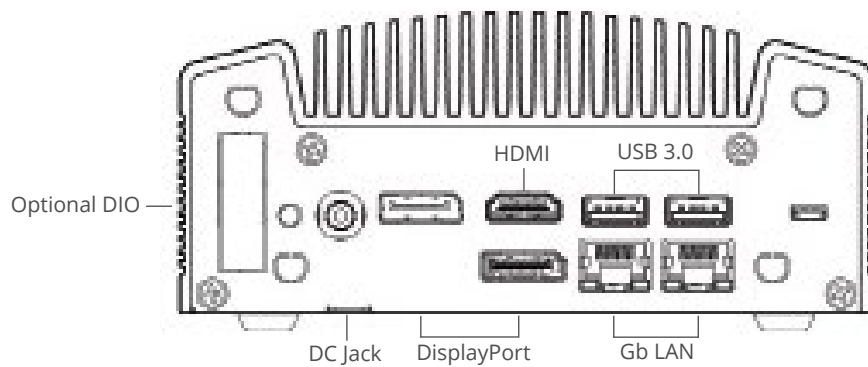
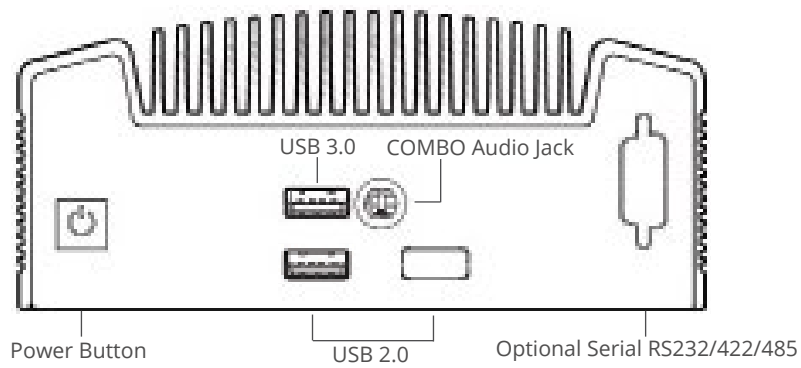
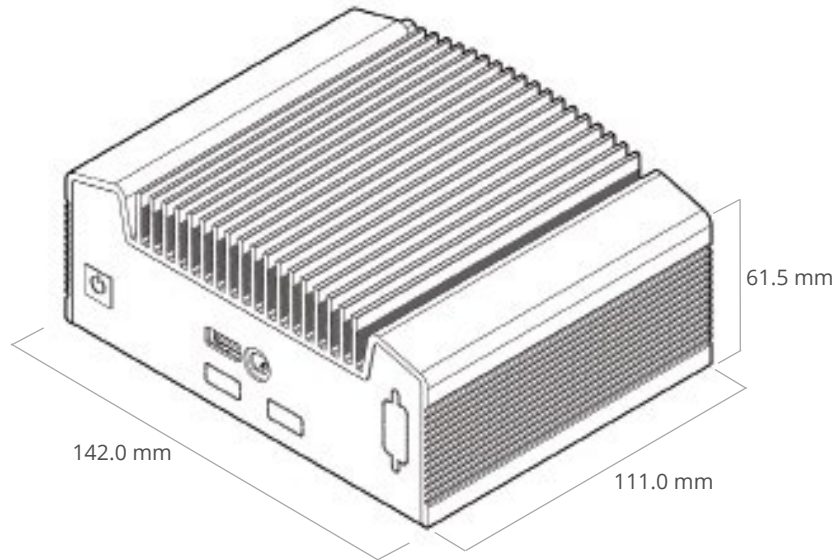

2.2 - System Specifications

	ML100G-51	ML100G-52	
	NUC-8265U	NUC-8365UE	NUC-8665UE
Processor	Intel® 8th Gen i5-8265U	Intel® 8th Gen i5-8365UE	Intel® 8th Gen i7-8665UE
Memory Capacity	32 GB	64 GB	64 GB
Supported Features		vPro, TSX-NI	vPro, TSX-NI
Memory Type	DDR4 SO-DIMM		
Processor Graphics	Intel® UHD Graphics 620		
Supported OS	Windows 10, Ubuntu 18		
Power Input	12VDC Jack		
Expansion	1 x M.2 2230 E-Key (PCIe x 1 + USB)		
Storage	1 x M.2 socket (2242/2260, SATA/PCIex4)		
Ethernet	1 x Intel® I219V + 1 x Realtek RTL8111G		
Rear I/O	1 x DC In-Jack		
	2 x RJ45 (w/LED)		
	1 x HDMI (max resolution up to 4K x 2K at 30Hz)		
	2 x Display Port (max resolution up to 3840 x 2160 at 60Hz)		
	2 x USB 3.0		
Front I/O	1 x DIO 4 in / 4 out (optional)		
	1 x COMBO Audio Jack (Headphone + MIC)		
	1 x USB 3.0		
Environment	RS-232/422/485 COM (optional)		
	Operating Temperature: 0°C ~ 50°C		
	Operation Humidity: 10%~ 95%		
	Storage Temperature: -40°C ~ 85°C		
Mounting	Storage Humidity: 0%~ 95%		
	Wall, DIN, VESA-100 (Additional mounting hardware required)		

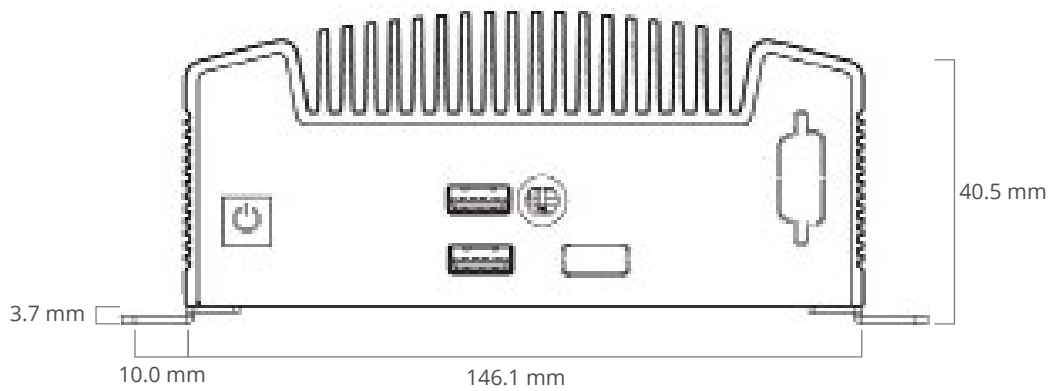
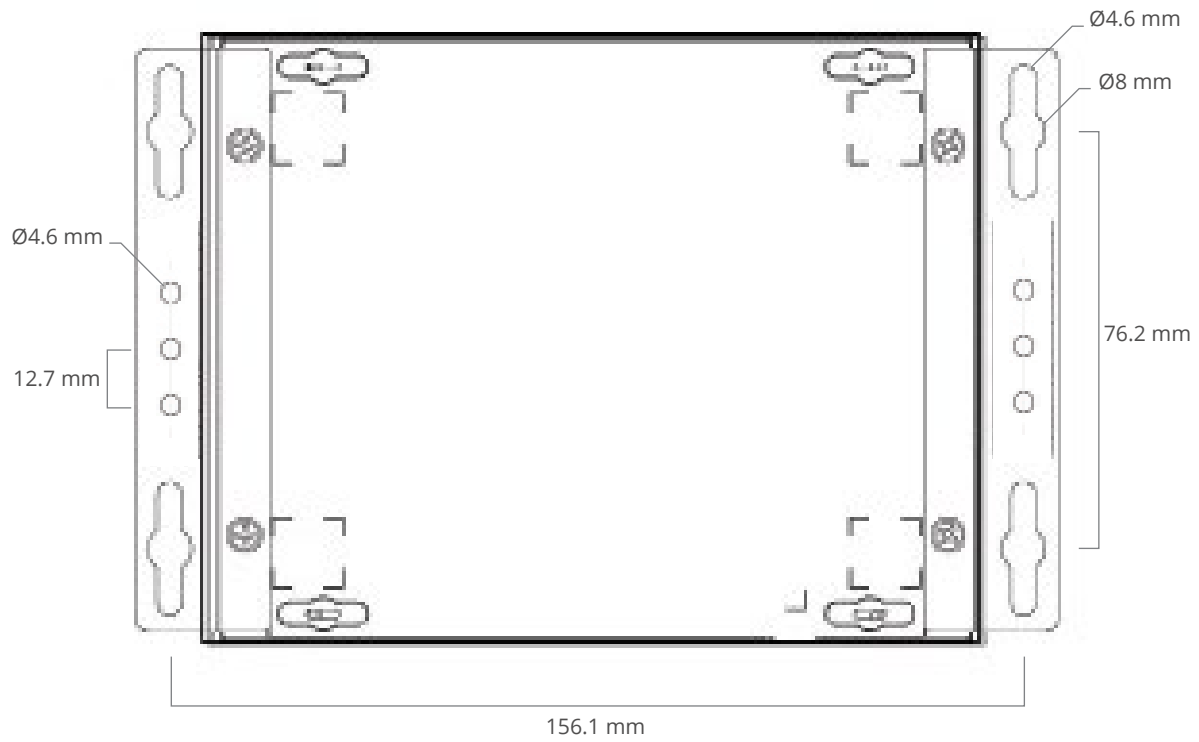
2.3 - Mounting Hole Pattern

2.4 - Mounting Guide

Desk Mounting

- Step 1: Attach wall mount brackets to chassis
- Step 2: Mark and prep holes in surface for mounting
- Step 3: Fasten system to surface

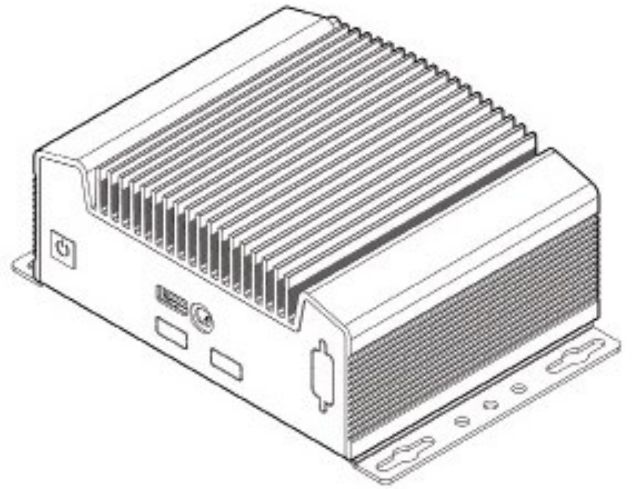

VESA Mounting

- Step 1: Install 4 VESA Screws into your display/surface
- Step 2: Attach VESA bracket to the chassis
- Step 3: Hang combined system and bracket to display/surface

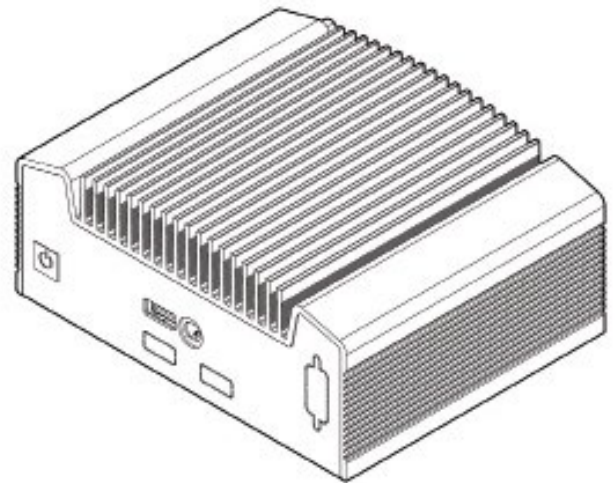

DIN Rail Mounting

- Step 1: Attach wall mounting brackets to the chassis
- Step 2: Attach DIN Rail Clips to the mounting brackets
- Step 3: Clip system to the DIN Rail

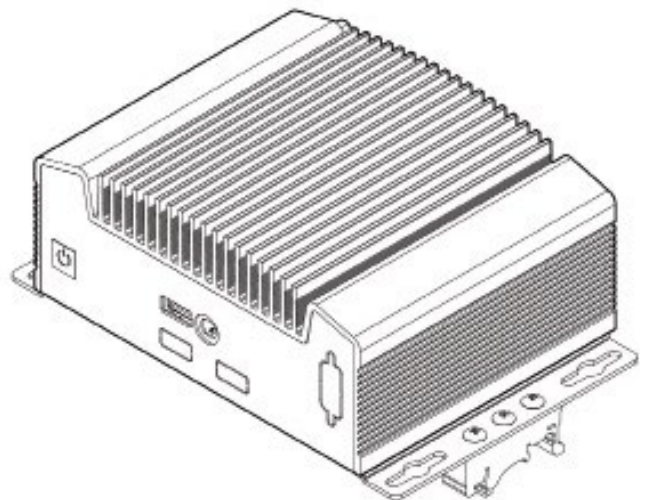

3 - Motherboard Overview

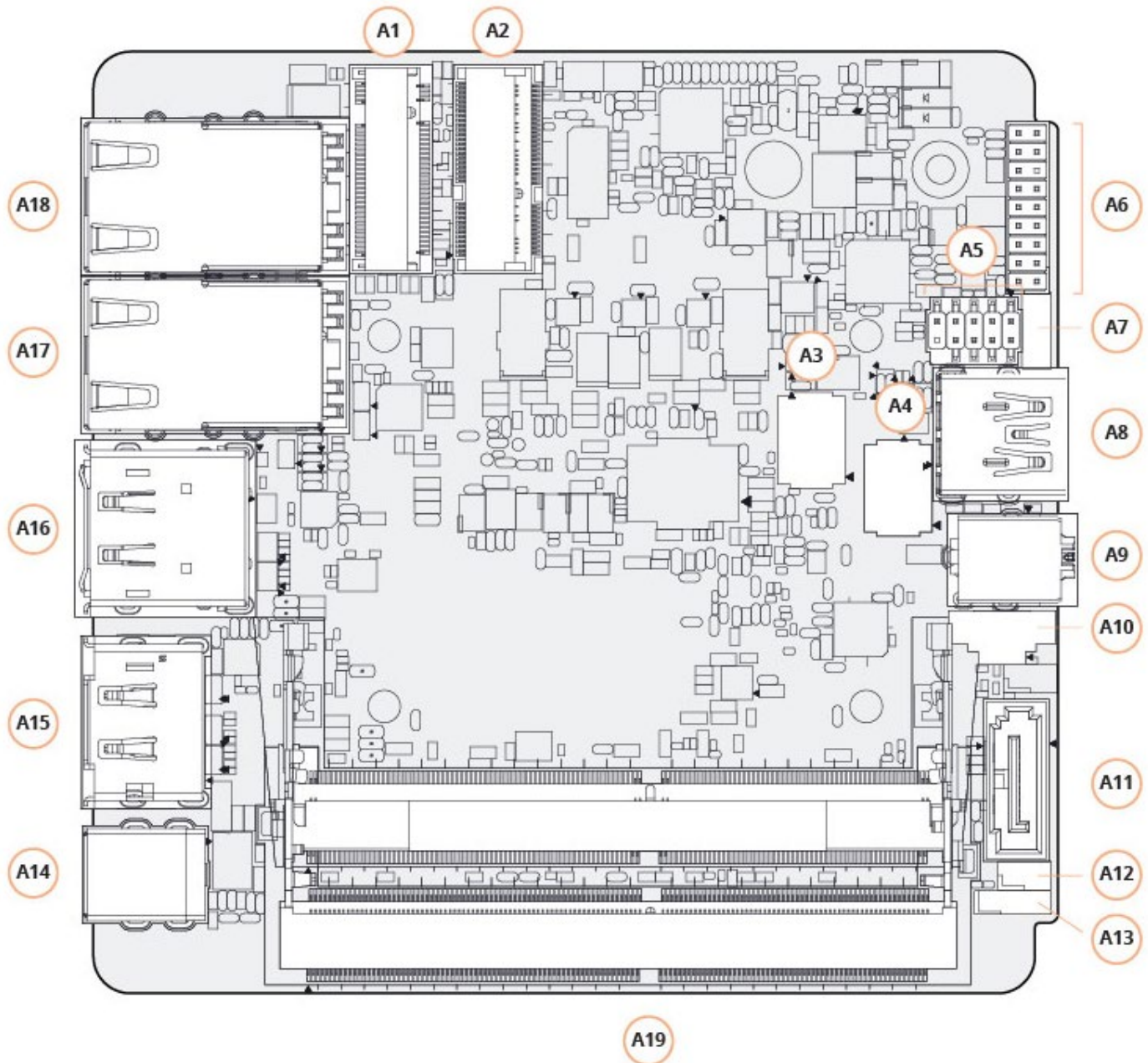

3.1 - Jumpers and Headers Guide

Number	Location	Function
1	M2M_1	M.2 Key-M Socket 2242/2260 (SATA/PCIe x4)
2	M2E_1	M.2 Key-E Socket 2230 (USB + PCIe x1)
3	USB2_3_4	USB 2.0 Connector
4	COM1	COM Port Header (RS232/422/485)
5	PANEL1	System Panel Header
6	LPC1	LPC Debug Header
7	PWR_JP1	ATX/AT Mode Jumper
8	USB3_3	USB 3.1 Gen 1 Port
9	AUDIO1	Audio Jack
10	SATA_PWR1	SATA Power Output Connector
11	SATA3_1	SATA3 Connector
12	M2_SEL2	M.2 Select
13	CLRMOS1	BIOS Reset
14	DC_JACK1	DC-In Jack
15	DISPLAY1	Display Port (Max Resolution 3840 x 2160 @ 60 Hz)
16	DP2	Display Port (Top)
	HDMI1	HDMI Port (Bottom) (Max Resolution 4K x 2K @ 30 Hz)
17	LAN2	RJ-45 LAN Port (Top)
	USB3_2	USB 3.1 Gen 1 Port (Bottom)
18	LAN1	RJ_45 LAN Port
	USB3_1	USB 3.1 Gen 1 Port
19	DDR4_B1	Memory Slots
	DDR4_A1	
Back Side	PWR_BTN1	Power Button
	FAN1	Fan Connector

Refer to the following diagrams for configuring jumpers and onboard headers.

3.2 - Configuring Jumpers

CLRMOS1

The CLRMOS1 jumper loads the default BIOS settings. Short pins 1-2 for normal operation. Short pins 2-3 to clear the CMOS and reset the system setup configuration to default settings. If you experience challenges powering up, short pins 2-3 to reset the BIOS.



PWR_JP1

AT = Auto power on.

ATX = No auto power on.

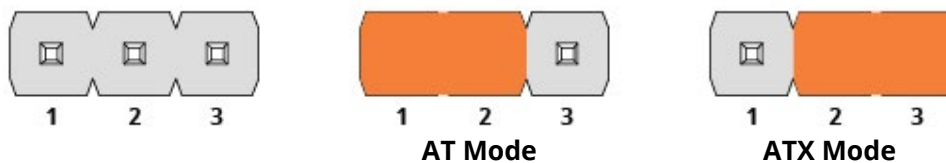

3.3 - Onboard Headers

An onboard header is a connection on the motherboard that permits connecting a peripheral component to an external port on the system.

USB2_3_4

The USB2_3_4 connector supports two USB ports.

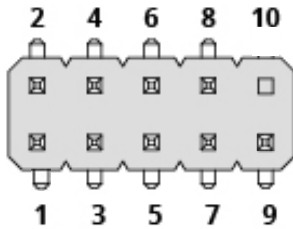

1	5V_USB
3	Data (Negative)
5	Data (Positive)
7	GND
9	NC

2	5V_USB
4	Data (Negative)
6	Data (Positive)
8	GND
10	Key

COM1

The motherboard includes an I/O COM Port at 0x3F8 IRQ4 and can support RS232/RS422/RS485.

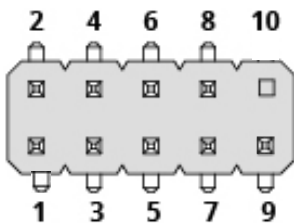

	RS232	RS422	RS485
1	DCD	TX (negative)	RTX (negative)
2	RXD#	TX (positive)	RTX (positive)
3	TXD#	RX (positive)	N/A
4	DTR	RX (negative)	N/A
5	GND	GND	GND
6	DSR	N/A	N/A
7	RTS	N/A	N/A
8	CTS	N/A	N/A
9	RI	N/A	N/A
10	Key	N/A	N/A

PANEL1

The system panel header controls the power on and reset buttons, as well as Hard Drive LEDs (HDLED) and Power LEDs (PLED).

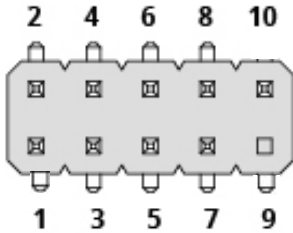

1	HDLED (Positive)	2	PLED (Positive)
3	HDLED (Negative)	4	PLED (Negative)
5	GND	6	PWRBTN
7	RESET	8	GND
9	GND	10	None

LPC1

The motherboard includes a Low Pin Count (LPC) debug header as a troubleshooting solution.

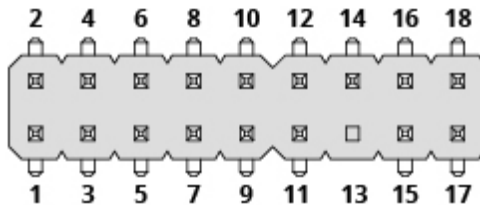

1	PCICLK	2	GND
3	FRAME	4	SMBus Clock
5	PCIRST	6	SMBus Data
7	LAD3	8	LAD2
9	3V	10	LAD1
11	LAD0	12	GND
13	None	14	S ₂ _PWRDWN
15	3V_SB	16	SERIRQ
17	GND	18	GND