

XM1

User Manual

Rugged GPU Computing System
Supports Intel® Raptor Lake-S / Alder Lake-S
Core-i Processors



PREFACE



Copyright Notice

No part of this document may be reproduced, copied, translated, or transmitted in any form or by any means, electronic or mechanical, for any purpose, without the prior written permission of OnLogic. All information and specification provided in this manual are for reference only and remain subject to change without prior notice.



Disclaimer

We reserve the right to make changes, without notice, to any product, including circuits and/or software described or contained in this manual in order to improve design and/or performance. We assume no responsibility or liability for the use of the described product(s) conveys no license or title under any patent, copyright, or masks work rights to these products, and make no representations or warranties that these products are free from patent, copyright, or mask work right infringement, unless otherwise specified. Applications that are described in this manual are for illustration purposes only. We make no representation or guarantee that such application will be suitable for the specified use without further testing or modification.

Declaration of Conformity

	<p>FCC</p> <p>This equipment has been tested and found to comply with the limits for a class "A" digital device, pursuant to part 15 of the FCC rules. These limits are designed to provide reasonable protection against harmful interference when the equipment is operated in a commercial environment. This equipment generates, uses, and can radiate radio frequency energy and, if not installed and used in accordance with the instruction manual, may cause harmful interference to radio communications. Operation of this equipment in a residential area is likely to cause harmful interference in which case the user will be required to correct the interference at him own expense.</p>
	<p>CE</p> <p>This equipment is in conformity with the requirement of the following EU legislations and harmonized standards. Product also complies with the Council directions.</p>

Safety Information

	<p>WARNING! / AVERTISSEMENT!</p> <p>Always completely disconnect the power cord from your chassis whenever you work with the hardware. Do not make connections while the power is on. Sensitive electronic components can be damaged by sudden power surges. Only experienced electronics personnel should open the PC chassis, and assemble the power supply with power cable connection.</p>
	<p>CAUTION/ATTENTION</p> <p>Always ground yourself to remove any static charge before touching the CPU card. Modern electronic devices are very sensitive to static electric charges. As a safety precaution, use a grounding wrist strap at all times. Place all electronic components in a static-dissipative surface or static-shielded bag when they are not in the chassis.</p>

Safety Precautions

For your safety, please carefully read all the safety instructions before using the device. All cautions and warnings on the equipment should be noted. Keep this user manual for future reference.

***Let licensed electricity engineer to check the equipment in case any of the following problems appear:**

- The power cord or plug is damaged.
- Liquid has penetrated into the equipment.
- The equipment has been exposed to moisture.
- The equipment does not work well or you cannot get it to work according to the user manual.
- The equipment has been dropped and damaged.
- The equipment has obvious signs of breakage on the surface.

***Only licensed electricity engineer should open the PC chassis, or assemble the power supply with power cable connection.**

Packing List

Item	Description	Q'ty
1	XM1 Rugged GPU Computing System	1
2	Wall Mount Brackets (2 pcs in 1 set)	1
3	Screw Pack (For Wall Mount Bracket)	1
4	4-pin Terminal Block Power Connector (For DC Power Input)	2
5	2-pin Terminal Block Power Connector (For Remote Power Control)	1
6	GPU card to riser board power cable (3 types, 2 pcs for each type)	6

CONTENTS

PREFACE	1
CHAPTER 1: INTRODUCTION	7
1.1 Overview	7
1.2 Product Features	8
1.3 CPU Options	9
1.4 GFX/AI Card Options.....	10
1.5 Hardware Specification	11
1.6 Mechanical Specification	14
1.7 System I/O Placement	16
CHAPTER 2: DIP SWITCH SETTING AND PIN DEFINITION	18
2.1 Jumper and Internal Connector Overall Placement.....	18
2.2 DIP Switch Setting	23
2.3 Internal Connector Pin Definition	25
2.4 External Connector Pin Definition.....	27
2.5 Xpansion Module MS-01IGN-S10.....	31
CHAPTER 3: SYSTEM SETUP.....	33
3.1 CPU, Memory, and M.2 M Key Module Installation.....	33
3.2 M.2 B Key/E Key/mPCIe Module Installation.....	36
3.3 PCIe Card Installation	37
3.4 RTC Battery Maintenance	38
3.5 1000W PSU Cable Assembly	39
CHAPTER 4: BIOS SETUP.....	41
4.1 Main Page.....	41
4.2 Advance Page	44
4.3 Security Page.....	60
4.4 Boot Page	66
4.5 Save & Exit Page	69
4.6 Event Logs.....	70

INTRODUCTION

This chapter provides the XM1 Rugged GPU Computing System product overview, including features, hardware and mechanical specifications.

1

CHAPTER 1: INTRODUCTION

This chapter provides the XM1 Rugged GPU Computing System product overview, including features, hardware, mechanical specifications, and I/O placement.

1.1 Overview

The XM1, a revolutionary embedded system powered by Intel 12th/13th Gen Core-i processors. With its unrivaled AI capabilities, this cutting-edge device takes innovation to the next level. Optional with 2 x high-end NVIDIA GFX cards (up to 600W + 600W), the XM1 harnesses the immense parallel computing power of NVIDIA GPUs to deliver advanced and multiplexed image processing for edge AI inference or machine learning tasks. Its expandable design caters to the demands of high-performance applications while its rugged construction ensures durability in even the harshest environments. Tailored for AI inference in factory automation, intelligent transportation systems, smart cities, and smart retail, the XM1 is the pinnacle of embedded AI systems.

It revolutionizes AI and edge computing, offering numerous benefits for deploying the XM1 at the edge. Its integration of Intel's latest processor technology provides unparalleled processing power, enabling real-time decision-making and accelerated AI inference at the edge. The optional inclusion of two high-end NVIDIA GFX cards unlocks exceptional parallel computing, reducing latency and dependence on the cloud. With expandability, it caters to evolving edge needs, while its rugged construction ensures reliable operation in harsh environments. By choosing the XM1, you empower your edge infrastructure with cutting-edge AI capabilities, faster insights, enhanced data privacy, and efficient edge deployments.

1.2 Product Features

XM1 Rugged GPU Computing System features:

- Intel 12th/13th/14th Gen Core
- SO-DIMM DDR5 x2 (Up to 4800/5600MHz and 64GB)
- Support Dual high-end GFX cards (**600W+600W**)
- Power Budget **1500W** system power consumption
- Hot Swappable 2.5/3.5" HDD Tray x4 & CFAST slot
- Exp.: PCIe x16/8, PCIe x4, PCIe x4, PCIe x8, PCIe x1
- Wide Voltage Input from **9V to 48V**

1.3 CPU Compatibility

Processor Name	Cache	E Core Base Clock	P Core Base Clock	Boost Clock	Cores	Threads	TDP
13th Generation Intel® Raptor Lake-S							
Intel® Core™ i9-13900 Processor	36M	1.50 GHz	2.00 GHz	5.60 GHz	8 + 16	32	65W
Intel® Core™ i9-13900E Processor	36M	1.30 GHz	1.80 GHz	5.20 GHz	8 + 16	32	65W
Intel® Core™ i9-13900TE Processor	36M	800 MHz	1.00 GHz	5.00 GHz	8 + 16	32	35W
Intel® Core™ i7-13700 Processor	30M	1.50 GHz	2.10 GHz	5.20 GHz	8 + 8	24	65W
Intel® Core™ i7-13700E Processor	30M	1.30 GHz	1.90 GHz	5.10 GHz	8 + 8	24	65W
Intel® Core™ i7-13700TE Processor	30M	800 MHz	1.10 GHz	4.80 GHz	8 + 8	24	35W
Intel® Core™ i5-13500 Processor	24M	1.80 GHz	2.50 GHz	4.80 GHz	6 + 8	20	65W
Intel® Core™ i5-13500E Processor	24M	1.50 GHz	2.40 GHz	4.60 GHz	6 + 8	20	65W
Intel® Core™ i5-13500TE Processor	24M	1.10 GHz	1.30 GHz	4.50 GHz	6 + 8	20	35W
Intel® Core™ i3-13100 Processor	12M	-	3.40 GHz	4.50 GHz	4	8	60W
Intel® Core™ i3-13100E Processor	12M	-	3.30 GHz	4.40 GHz	4	8	60W
Intel® Core™ i3-13100TE Processor	12M	-	2.40 GHz	4.10 GHz	4	8	35W
12th Generation Intel® Alder Lake-S							
Intel® Core™ i9-12900 Processor	30M	1.80 GHz	2.40 GHz	5.10 GHz	8 + 8	24	65W
Intel® Core™ i9-12900E Processor	30M	1.70 GHz	2.30 GHz	5.00 GHz	8 + 8	24	65W
Intel® Core™ i9-12900TE Processor	30M	1.00 GHz	1.10 GHz	4.80 GHz	8 + 8	24	35W
Intel® Core™ i7-12700 Processor	25M	1.60 GHz	2.10 GHz	4.90 GHz	4 + 8	20	65W
Intel® Core™ i7-12700E Processor	25M	1.60 GHz	2.10 GHz	4.80 GHz	4 + 8	20	65W
Intel® Core™ i7-12700TE Processor	25M	1.00 GHz	1.40 GHz	4.60 GHz	4 + 8	20	35W
Intel® Core™ i5-12500 Processor	18M	-	3.00 GHz	4.60 GHz	6	12	65W
Intel® Core™ i5-12500E Processor	18M	-	2.90 GHz	4.50 GHz	6	12	65W
Intel® Core™ i5-12500TE Processor	18M	-	1.90 GHz	4.30 GHz	6	12	35W
Intel® Core™ i3-12100 Processor	12M	-	3.30 GHz	4.30 GHz	4	8	60W
Intel® Core™ i3-12100E Processor	12M	-	3.20 GHz	4.20 GHz	4	8	60W
Intel® Core™ i3-12100TE Processor	12M	-	2.10 GHz	4.00 GHz	4	8	35W
Intel® Pentium® G7400E Processor	6M	-	3.60 GHz	-	2	2	46W
Intel® Pentium® G7400TE Processor	6M	-	3.00 GHz	-	2	2	35W
Intel® Celeron® G6900E Processor	4M	-	3.00 GHz	-	2	2	46W
Intel® Celeron® G6900TE Processor	4M	-	2.40 GHz	-	2	2	35W

1.4 GFX/AI Card Compatibility

Model Name	Display	Memory	CUDA	TDP
NVIDIA A40 48GB <i>*with optional fan duct kit</i>	3 x DP1.4a	48 GB GDDR6	10,752	300W
NVIDIA RTX 6000 Ada Gen.	4 x DP1.4a	24 GB GDDR6	18,176	300W
NVIDIA RTX A6000 48GB	4 x DP1.4a	48 GB GDDR6	10,752	300W
NVIDIA RTX A5500 24GB	4 x DP1.4a	24 GB GDDR6	10,240	230W
NVIDIA RTX A5000 24GB	4 x DP1.4a	24 GB GDDR6	8,192	230W
NVIDIA RTX A4500 20GB	4 x DP1.4a	20 GB GDDR6	7,168	200W
NVIDIA RTX 4000 SFF Ada Gen. 20GB	4 x mDP1.4a	20 GB GDDR6	6,144	70W
NVIDIA RTX A4000 16GB	4 x DP1.4a	16 GB GDDR6	6,144	140W
NVIDIA RTX A2000 12GB	4 x mDP1.4	12 GB GDDR6	3,328	70W
NVIDIA Quadro T1000 8GB	4 x mDP1.4	8 GB GDDR6	896	50W
NVIDIA Quadro T1000 4GB	4 x mDP1.4	4 GB GDDR6	896	50W
NVIDIA Quadro T400 4GB	3 x mDP1.4	4 GB GDDR6	384	30W
Leadtek RTX 4090 AI Blower 24GB	1 x HDMI2.1 3 x DP1.4a	24 GB GDDR6	16,384	450W
Leadtek RTX 4080 AI Blower 16GB	1 x HDMI2.1 3 x DP1.4a	16 GB GDDR6	9,728	320W
Leadtek RTX 4070 AI BLOWER 12GB	1 x HDMI2.1 3 x DP1.4a	12 GB GDDR6	5,888	200W
Leadtek RTX 3060 Classic 12GB (LHR)ver.B	1 x HDMI2.1 3 x DP1.4a	12 GB GDDR6	3,584	170W

1.5 Hardware Specification

System	
Processor	13th/12th Gen Intel® Raptor Lake-S/Alder Lake-S Core i9/i7/i5/i3/Celeron/Pentium
Chipset	Intel® R680E
Memory	2 x 262-pin SO-DIMM / DDR5 4800/5600* MHz / Max. 64 GB (Non-ECC) *13 th Gen Intel Raptor Lake-S Core i9/i7 SKUs can support up to 5600MHz
Audio	Realtek® ALC888S
Super I/O	Nuvoton NCT6126D
LAN	Intel® i225LM Gigabit (10/100/1000/2500 Mb/s) LAN
	Intel® i225V Gigabit (10/100/1000/2500 Mb/s) LAN
TPM IC	Nuvoton NPCT750AAAYX TPM2.0
Expansion	M.2 3042 / 3052 / 2242 / 2260 / 2280 B key (USB3.0, SATAIII, *PClex1) w/ SIM slot*2
	M.2 2230/ 2242 / 2260 / 2280 M key (PClex4 NVME, SATAIII)
	M.2 2230 E key (CNVi, PClex1, USB 2.0)
	Mini PCIe Full size*1 (USB2.0 / SATAIII / PClex1) w/ SIM slot*1
	Mini PCIe Full size*1 (USB2.0 / PClex1) w/ SIM slot*1
	Hot Swappable 2.5" HDD Tray*2, 3.5" HDD Tray*2
	Removable CFast slot*1
	PCle Slot#1: PCIe x16 or PCIe x8 (switch by jumper setting) in PClex16 physical connector
	PCle Slot#2: PCIe x4 in PClex16 physical connector
	PCle Slot#3: PCIe x4 in PClex16 physical connector
	PCle Slot#4: Blank or PCIe x8 (switch by jumper setting) in PClex16 physical connector
	PCle Slot#5: PCIe x1 in Gen3 open-ended connector
Xpansion header for Optional Vehicle Power Ignition Xpansion "MS-01IGN-S10" for delay power on/off	
BIOS	AMI
Front I/O	4-pin Terminal Block x2 for power connectors
	1 x Removable CFast Slot
	SIM slot x4 (with door plate, mapping to 2 x mPCIe and 1 x M.2 B Key slots)
Side I/O	2 x Hot Swappable 2.5" HDD Tray (support 7-9.5mm height) 2 x Hot Swappable 3.5" HDD Tray

Rear I/O	Power/HDD LED
	Power ON/OFF button
	3 x RS232 (support power 5V/12V)
	1 x RS232/422/485 (support power 5V/12V)
	1 x DB37 connector for 32-bit DIO
	1 x HDMI 2.0b
	1 x VGA
	1 x DisplayPort 1.4
	2 x 2.5G RJ45 LAN Ports
	4 x USB3.1 Gen2
	4 x USB3.1 Gen1
	2 x USB2.0
	1 x Line out, 1 x Mic-in
	5 x PCIe Slot
	1 x Remote power on/off 2-pin terminal block
6 x Antenna SMA Hole with cap	
Internal I/O	1 x USB3.2 Gen1 TYPE A
	1 x USB2.0 TYPE A
	4 x 8PIN PEG Header
	Battery Holder with RTC Coin Battery
	Clear CMOS switch
POWER REQUIREMENT	
Power Input	9~48V Wide Range DC Input w/ Terminal Block Connectivity
Power Adaptor	Optional 300W/1000W AC to DC PSU
MECHANICAL	
Thermal Design	Fan
Mounting	Wallmount
Dimension (W X D X H)	264 x 415 x 256mm
Weight	13kg (28.7 lb)
ENVIRONMENTAL	
Operating Temperature	<p>a. <u>XM1 without GPU Card:</u> 35W TDP Processor: -40°C to 70°C 65W TDP Processor: -40°C to 60°C (with 0.7m/s Air Flow and Wide Temperature Memory/Storage)</p>
	<p>b. <u>XM1 with dual NVIDIA RTX40X0/Quadro GPU Cards*:</u> 35W TDP Processor: -20°C to 60°C 65W TDP Processor: -20°C to 50°C (with 0.7m/s Air Flow and Wide Temperature Memory/Storage)</p>

	<p>c. <u>XM1 with dual NVIDIA A40/AI Cards and optional fan duct:</u> 35W~125W TDP Processor: -20°C to 35°C (with 0.7m/s Air Flow and Wide Temperature Memory/Storage)</p> <p>*Please consult with your sales contact window about the Operating Temperature of GPU Card Configurations</p> <p>*Max OT limit -10°C with dual GPU card and with 0.7m/s Air Flow and Wide Temperature Memory/Storage</p>
Storage Temperature	-40 ~ 85°C (-40 ~185°F)
Operating Humidity	10% ~ 90% R/H (Non-condensing)
Storage Humidity	10% ~ 95% @85°C non-condensing
Vibration Resistance	MIL-STD-810H, Follow Method 514.8C-I Category 4 for Truck
Shock Resistance	MIL-STD-810H 516.8 procedure I - functional shock, Operating 20G, 11ms (Follow IEC 60068-2-27 half sine)
Certification	CE, FCC class A
OS	
OS Support	Windows® 11 64bit, / Windows® 10 IoT LTSC 64bit (LTSC 2021) / Ubuntu 22.04



**Note¹: Please make sure that the power consumption is in the spec of the power supply output capability from AC adaptor (300W or 1000W). Please choose the suitable AC adaptor for your application.*

AC/DC 24V/12.5A, 300W Terminal Block Power Adaptor

AC/DC 48V/9.20.8A, 1000W Power Supply



**Note²: The safety ambient operating temperature is 40 degree C if the external AC adapter model: EA13001N will be placed in the same high temperature area with the embedded system.*



**Note³: CAUTION - Lithium battery is included in this embedded system. Please do not puncture, mutilate, or dispose of battery in fire. There will be danger of explosion if battery is incorrectly replaced. Replace only with the same or equivalent type recommended by manufacturer. Dispose of used battery according to manufacturer instructions and in accordance with your local regulations.*



**Note⁴: Please read the BIOS release note before re-flashing BIOS. If the BIOS notes mention the BIOS will be loaded default after re-flashing BIOS, please check the BIOS setting again before boot up. For example, inconsistent RAID setting might cause system boot up issue.*



**Note⁵: When XM1 is installed with PCIe GFX card, the BIOS setup menu will only have display output via external graphic card.*

1.6 Mechanical Specification

XM1

- Mechanical Dimension: 264 x 415 x 256mm
- Maximum Dimension for single GFX card (System Fan put inside): 340 mm x 150 mm x 4 Slots

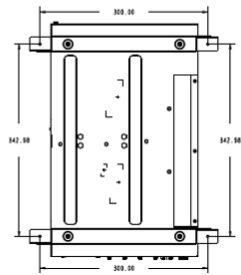
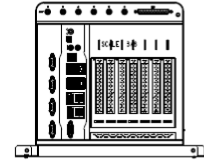
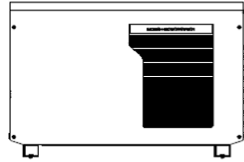
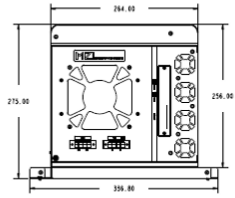
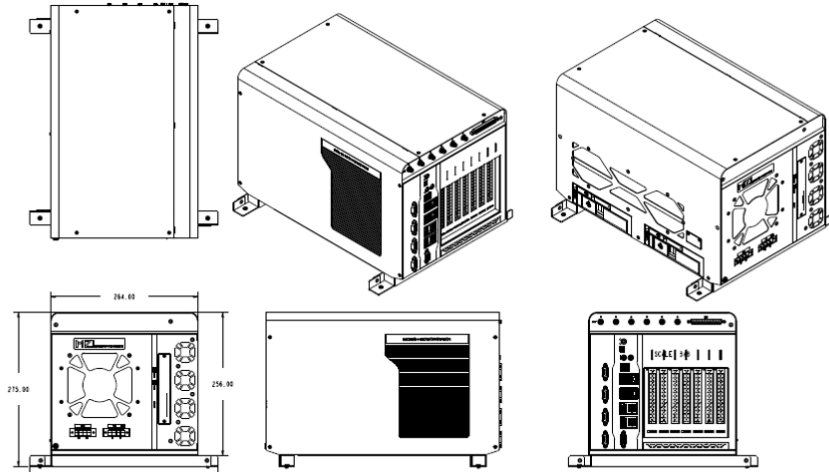
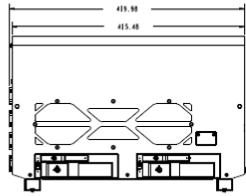

Yours

1.7 System I/O Placement

Front I/O

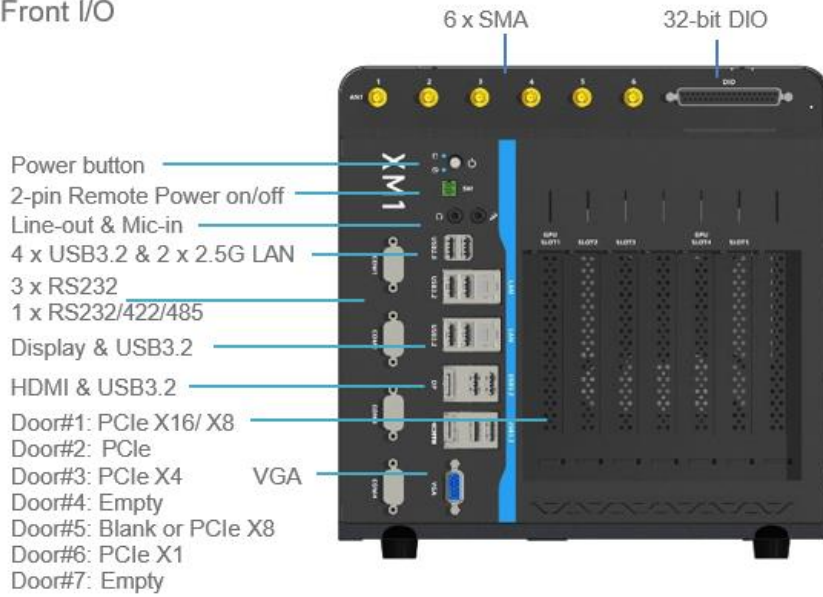

Side I/O

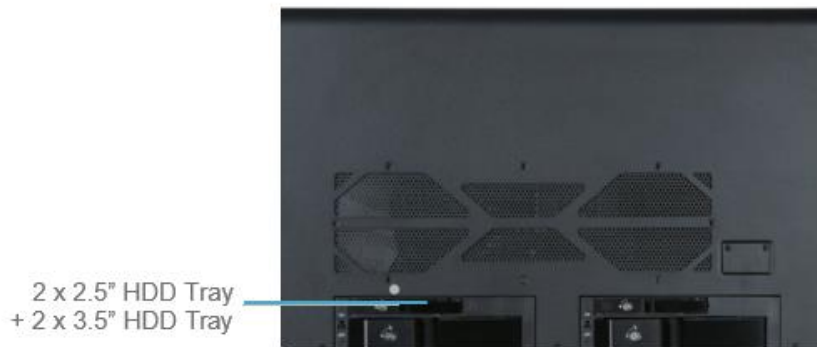

Rear I/O

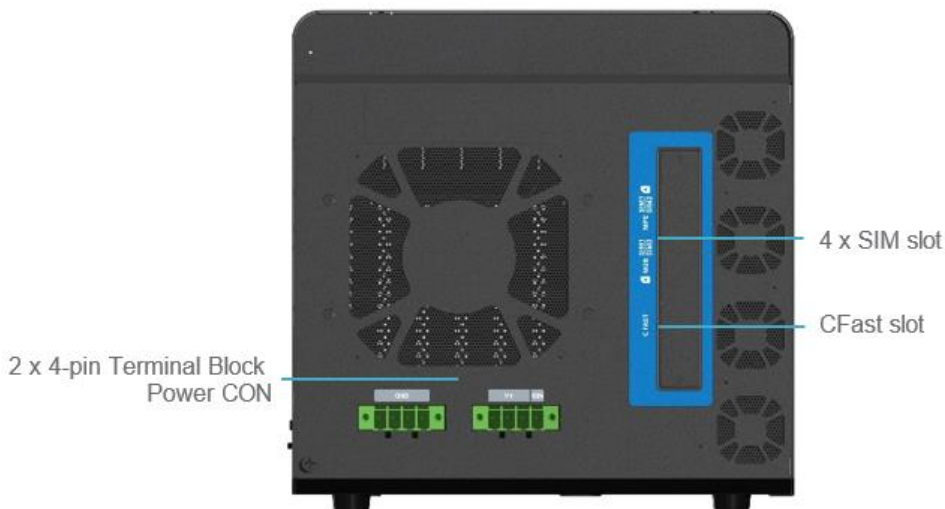

DIP SWITCH SETTING AND PIN DEFINITION

This chapter provides information about how to set up the dip switch and use internal I/Os of XM1 Rugged GPU Computing System hardware.

2

CHAPTER 2: DIP SWITCH SETTING AND PIN DEFINITION

This chapter provides information about how to set up the dip switch, and use internal I/Os of XM1 hardware.

2.1 Jumper and Internal Connector Overall Placement

2.1.1 Main Board Top side placement

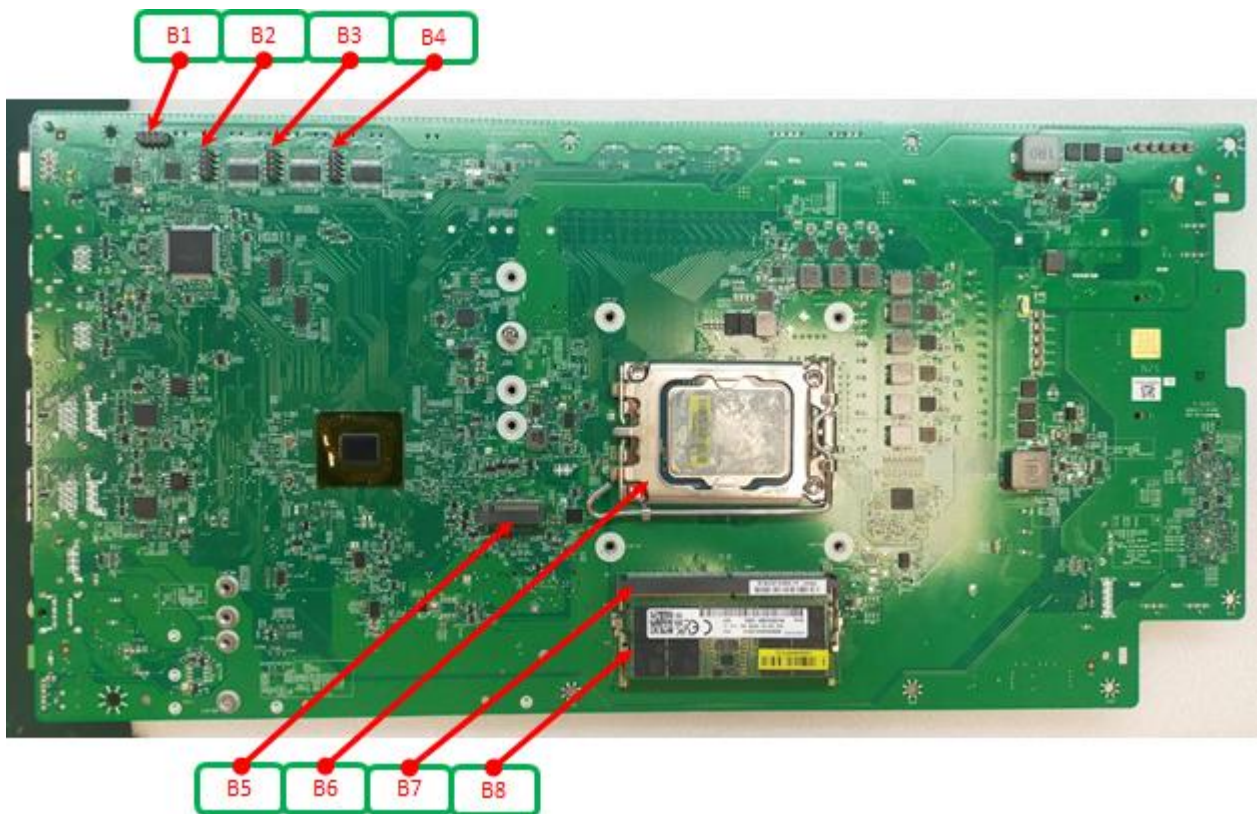

Item	Location	Interface
B1	COM1	RS232 5Px2_NP10
B2	COM2	RS232 5Px2_NP10
B3	COM3	RS232 5Px2_NP10
B4	COM4	RS232 5Px2_NP10
B5	M2M1	M2 key M: PCIe Gen4 x4, SATA SSD
B6	CPU1	Intel® Alder Lake Processor socket
B7	DIMM1	DDR5 So-DIMM socket
B8	DIMM2	DDR5 So-DIMM socket

2.1.2 Main Board Bottom side placement

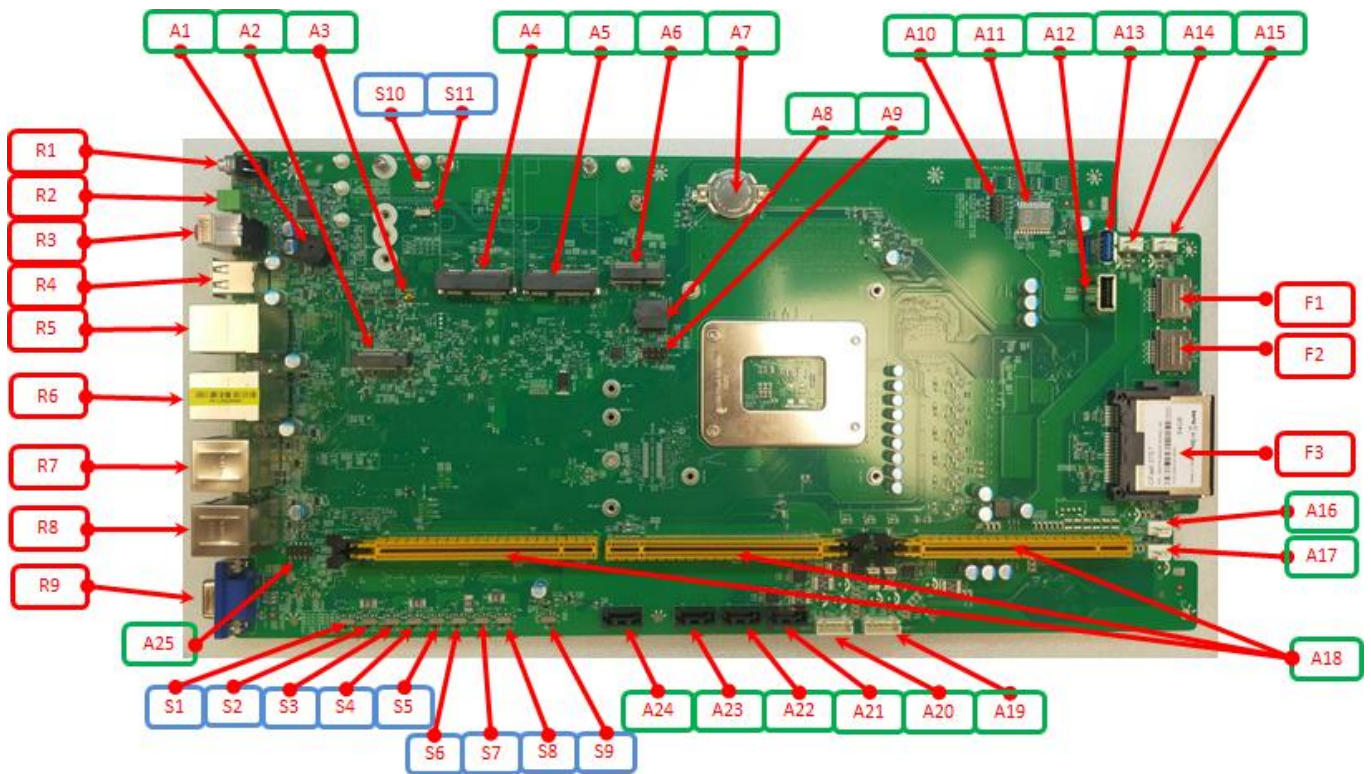

Item	Location	Interface
R1	PWRBT2	Power button
R2	JPWRBT1	Power button at PCB Screw Terminal Block, 2P, 3.5mm, R/A
R3	J55	Audio Jack: MIC IN + LINE OUT I/O
R4	J59	USB2.0 x2 I/O
R5	J43	USB3.0 x2 + RJ45 2.5G
R6	J42	USB3.0 x2 + RJ45 2.5G
R7	DP1	Display Port I/O
R8	J60	USB3.0 x2 high Rise I/O
R9	HD1	HDMI 1.4 4K 30 Hz
R10	J62	USB3.0 x2 high Rise I/O
R11	VGA1	VGA I/O

Item	Location	Interface
F1	MP_SIM1	Mini PCIe SIM card holder from mini PCIe Slot#1, #2
F2	M2B_SIM1	M2 keyB SIM card holder
F3	CF1	Audio Jack: MIC IN + LINE OUT I/O

Item	Location	Interface
A1	BZ1	Buzzer
A2	M2_KB1	M2 key B connector: 1. PCIe x1/ USB3.0/ SATA by DIP switch 2. USB2.0 3. 4G/5G SIM card
A3	RTCRST1	Clear CMIS button
A4	MINI_PCIE1	Mini_PcIE1: Support PCIe x1/ SATA + SIM card
A5	MINI_PCIE2	Mini_PcIE2: Support PCIe x1 + SIM card
A6	M2E	Me key E connector: PCIe x1, USB2.0
A7	BT1	battery CR2032 & socket
A8	UBIOS1	BIOS IC; MP to remove BIOS socket
A9	SPI_HDR1	BIOS F/W code update header
A10	JP80_LED1	P80 LED header support POST code message
A11	P80_LED_1	P80 LED module (Removed from MP)
A12	JUSB2	USB2.0 Type A
A13	J_USB3	USB3.0 Type A
A14	AUX_FAN1	Aux FAN1
A15	AUX_FAN2	Aux FAN2
A16	CPU_FAN1	CPU FAN1
A17	AUX_FAN3	Aux FAN3
A18	BRS_S1, BRS_S2, BRS_S3	Support Riser board
A19	SATA_P34	SATA PWR
A20	SATA_P12	SATA PWR
A21	SATA3	SATA3 header
A22	SATA2	SATA2 header
A23	SATA1	SATA1 header
A24	SATA0	SATA0 header
A25	J6	ESPI debug header

Item	Location	Interface
S1	Sw_P1_Pw_A	COM1 PWR 5V/12V setting 5V = Sw_P1_Pw_A 12V = Sw_P1_Pw_C
S2	Sw_P1_Ri_A	COM1 PWR/RI setting RI = SW_P1_RI_A PWR = SW_P1_RI_C
S3	Sw_P2_Pw_A	COM2 PWR 5V/12V setting 5V = Sw_P2_Pw_A 12V = Sw_P2_Pw_C
S4	Sw_P2_Ri_A	COM2 PWR/RI setting RI = SW_P2_RI_A PWR = SW_P2_RI_C
S5	Sw_P3_Pw_A	COM3 PWR 5V/12V setting 5V = Sw_P3_Pw_A 12V = Sw_P3_Pw_C
S6	Sw_P3_Ri_A	COM3 PWR/RI setting RI = SW_P3_RI_A PWR = SW_P3_RI_C
S7	Sw_P4_Pw_A	COM4 PWR 5V/12V setting 5V = Sw_P4_Pw_A 12V = Sw_P4_Pw_C
S8	Sw_P4_Ri_A	COM5 PWR/RI setting RI = SW_P4_RI_A PWR = SW_P4_RI_C
S9	Sw_At1	AT/ATX mode setting ATX default mode (Sw_At1_A) AT mode ((Sw_At1_C))
S10	M2b_Sw2_A	M2 Key B USB3.0 or PCIe_SATA HW setting PCIe/SATA = M2b_Sw2_A USB3.0 = M2b_Sw2_C
S11	M2b_Sw1_A	M2 Key B PCIe/SATA HW setting PCIe = M2b_Sw1_A + M2b_Sw2_A SATA = M2b_Sw1_C + M2b_Sw2_A

2.1.3 Riser Board Top side placement

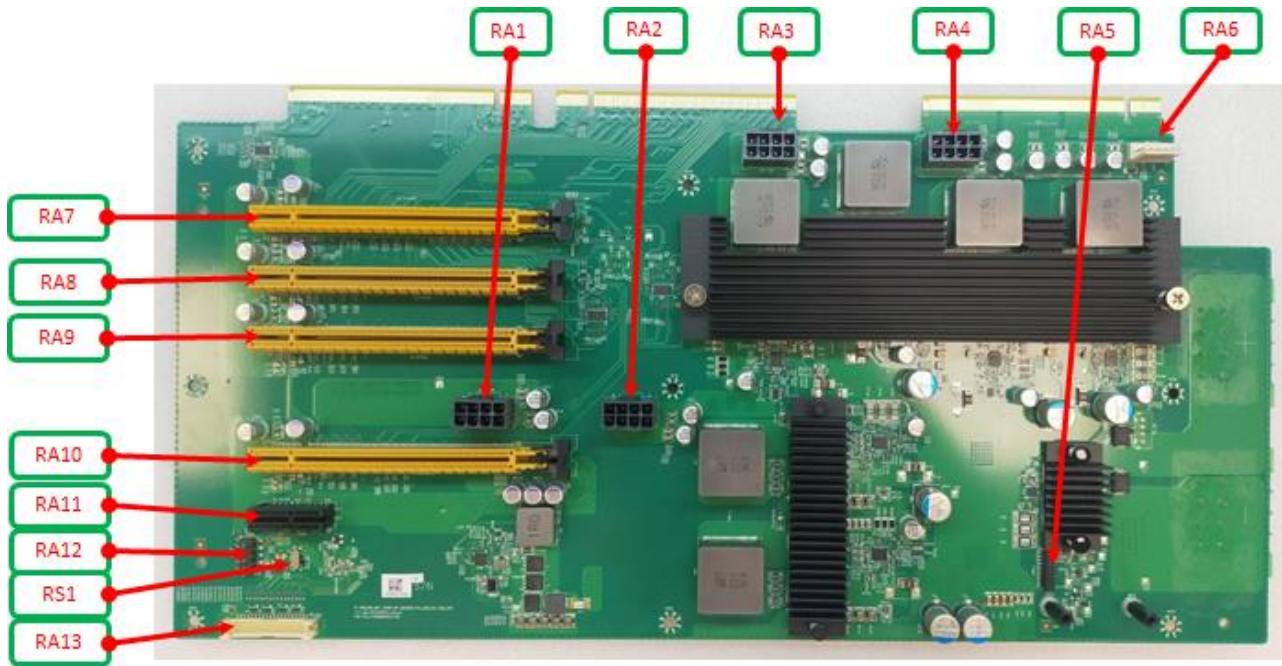

Item	Location	Interface
RA1	Gxf2_Pw1	Support PCIe Slot #4,#5 EXT PWR connector
RA2	Gxf2_Pw2	Support PCIe Slot #4,#5 EXT PWR connector
RA3	Gxf1_Pw1	Support PCIe Slot #1,#2,#3 EXT PWR connector
RA4	Gxf1_Pw2	Support PCIe Slot #1,#2,#3 EXT PWR connector
RA5	Btb_1	Support MS-01IGN-S10 Vehicle Power Ignition Card
RA6	Fan_Sys1	System FAN 6pin 2.5mm
RA7	S1_PClx16	Slot#1 : CPU PCIe X16 Gen4 or x8 with Slot#4 GXF card
RA8	S2_PClx4	Slot#2 : PCH PCIe x4 GEN4
RA9	S3_PClx4	Slot#3 : PCH PCIe x4 GEN4
RA10	S4_PClx8	Slot#4 : CPU PCIe X8 Gen4
RA11	S5_PClx1	Slot#5 : PCH PCIe x1 GEN3
RA12	J2	MCU NUC1262SE4AE F/W update header
RA13	Dio1	GPIO32 (8x4) header V_3P3V_5V_GPIO PWR is 5VSB / 3VSB
RS1	DIO_SW1	DIO_SW1 = A => 3.3V 1A DIO_SW1 = B => 5V 1A

2.2 DIP Switch Setting

■ M2 key B socket Interface at M2_KB1 Slot

- Support SATA SSD (HW settinh by HW DIP switch)
- Support PCIe1 SSD (HW settinh by HW DIP switch)
- Support USB3.0 (HW settinh by HW DIP switch)
- Support PCIe1 Gen1/Gen2/Gen3device (HW settinh by HW DIP switch)
- Support USB2.0 device

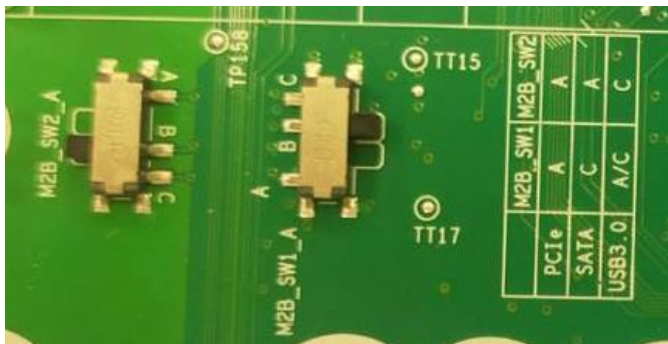

	M2B_SW1	M2B_SW2
PCle	A	A
SATA	C	A
USB3.0	A/C	C

HW setting by HW DIP switch

Item	Location	Interface
S10	M2b_Sw2_A	M2 Key B USB3.0 or PCIe_SATA HW setting PCIe/SATA = M2b_Sw2_A USB3.0 = M2b_Sw2_C
S11	M2b_Sw1_A	M2 Key B PCIe/SATA HW setting PCIe = M2b_Sw1_A + M2b_Sw2_A SATA = M2b_Sw1_C + M2b_Sw2_A

■ AT/ATX Mode Jumper

AT/ATX mode DIP SWITCH at SW_AT1 location

AT/ATX	Jumper Header location
Default –ATX mode	SW_AT1_A
Auto PWR ON – AT mode	SW_AT1_C

■ DIO V_5V_3V_40mil_P1 PWR setting guide



DIO_SW1	
A	VCC3
C	VCC

■ **Serial Port power DIP switch setting guide**

<i>Item</i>	<i>Location</i>	<i>Interface</i>
S1	Sw_P1_Pw_A	COM1 PWR 5V/12V setting 5V = A 12V = C
S2	Sw_P1_Ri_A	COM1 PWR/RI setting RI = A PWR = C
S3	Sw_P2_Pw_A	COM2 PWR 5V/12V setting 5V = A 12V = C
S4	Sw_P2_Ri_A	COM2 PWR/RI setting RI = A PWR = C
S5	Sw_P3_Pw_A	COM3 PWR 5V/12V setting 5V = A 12V = C
S6	Sw_P3_Ri_A	COM3 PWR/RI setting RI = A PWR = C
S7	Sw_P4_Pw_A	COM4 PWR 5V/12V setting 5V = A 12V = C
S8	Sw_P4_Ri_A	COM5 PWR/RI setting RI = A PWR = C

■ **BIOS / CMOS Clear Button (RTCST1)**



2.3 Internal Connector Pin Definition

■ GPU PWR connector

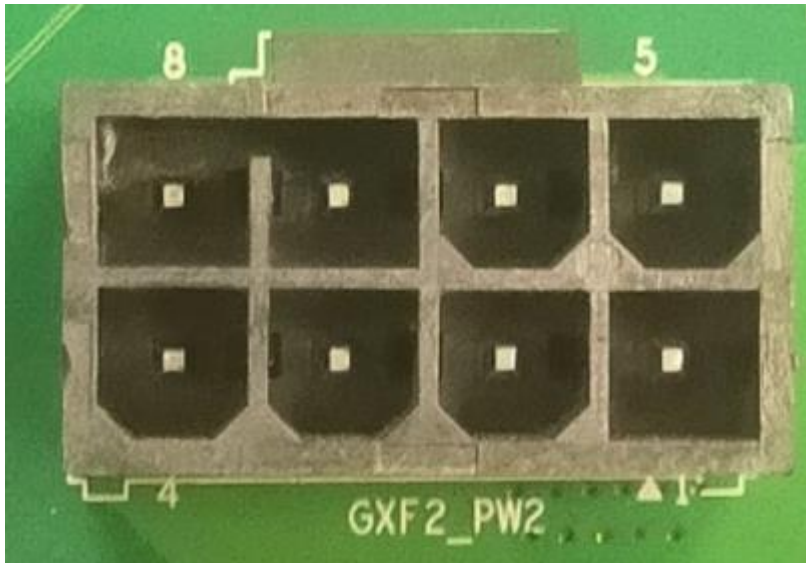

TF-CON;POWER,SBU,ATX,AC/600V,4P*2,MA,4.2mm,ST,LCP,BLACK,TIN,GPU

AMPHENOL LTD	G874D08E135C2HR
FOXCONN (HONG HAI PRECISION IN	HMDA040-L2B00-4H

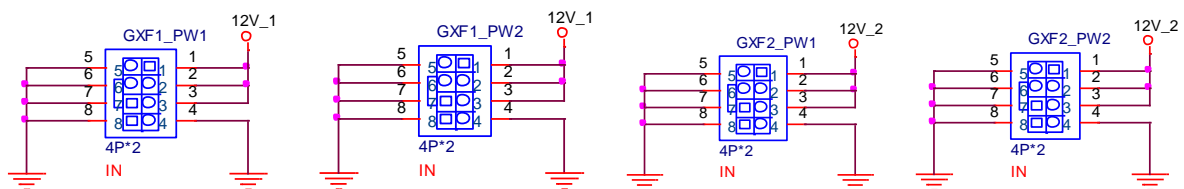

Support 600W at Gxf1_Pw1 + Gxf1_Pw2 2ea GPU PWR connector

Support 600W at Gxf2_Pw1 + Gxf2_Pw2 2ea GPU PWR connector

Notes: Don't support to short 12V_1 + 12V_2 2ea different PWR rail

Item	Location	Interface
RA1	Gxf2_Pw1	Support PCIe Slot #4,#5 EXT PWR connector
RA2	Gxf2_Pw2	Support PCIe Slot #4,#5 EXT PWR connector
RA3	Gxf1_Pw1	Support PCIe Slot #1,#2,#3 EXT PWR connector
RA4	Gxf1_Pw2	Support PCIe Slot #1,#2,#3 EXT PWR connector

■ PCIe Slot #1~#5

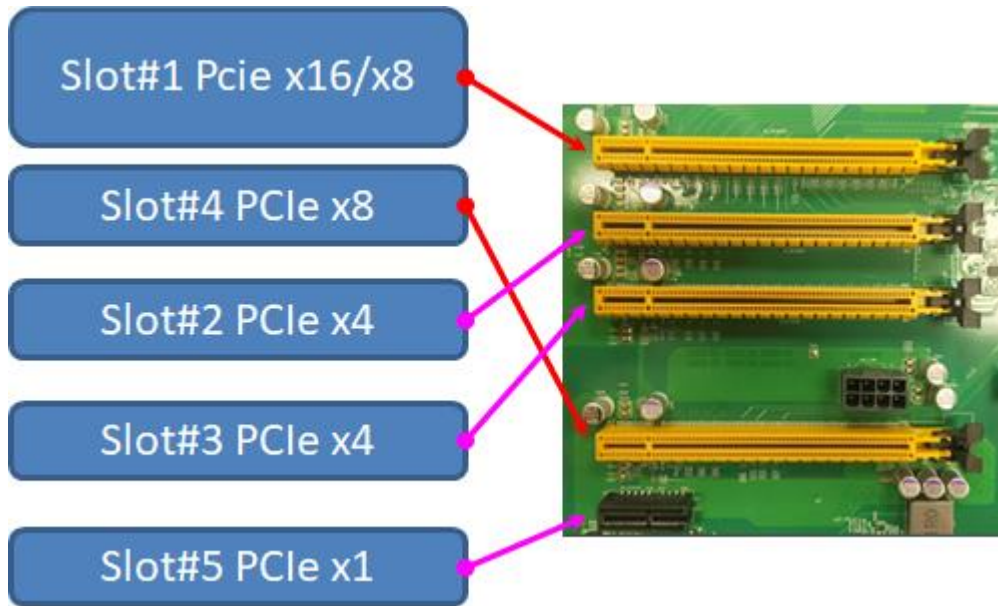

Item	Location	Interface
RA7	S1_PClcx16	Slot#1 : CPU PCIe X16 Gen4 or x8 with Slot#4 GXF card
RA8	S2_PClcx4	Slot#2 : PCH PCIe x4 GEN4
RA9	S3_PClcx4	Slot#3 : PCH PCIe x4 GEN4
RA10	S4_PClcx8	Slot#4 : CPU PCIe X8 Gen4
RA11	S5_PClcx1	Slot#5 : PCH PCIe x1 GEN3

2.4 External Connector Pin Definition

■ DC input power connector at DC_P1 & DC_P2 location

V_IN_A input PWR range from +12V~48V

12V max PWR = 600W

48V max PWR = 1500W

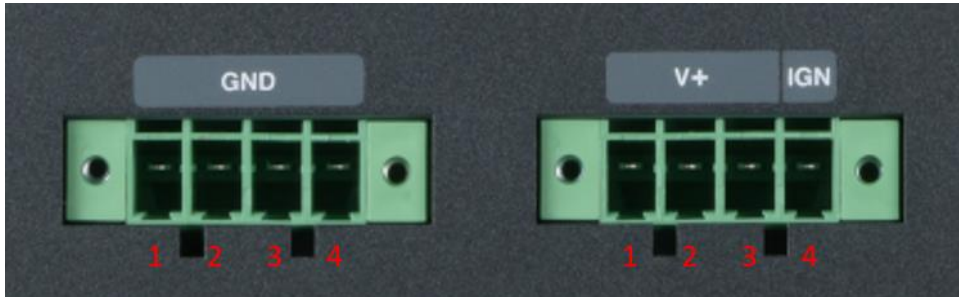

DC_P1 connector pinout

Pin	Signal Name
1	V_IN_A
2	V_IN_A
3	V_IN_A
4	CAR_IGN

DC_P2 connector pinout

Pin	Signal Name
1	GND
2	GND
3	GND
4	GND

■ **2-pin Terminal Block for Remote Power ON/OFF**

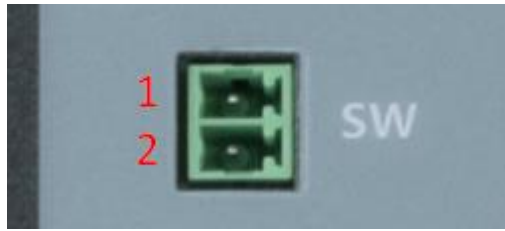

Pin	Signal
1	EXT_PWRBT_ON/OFF
2	Ground

■ **32-bit GPIO in DB37**

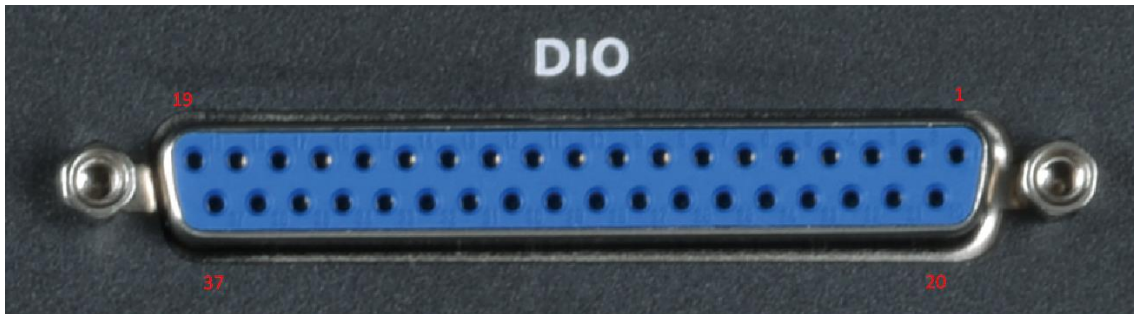

Pin#	DB37	Default GPIO Type
1	VCC	-
2	VCC	-
3	USBM_GPIOA0	Output Low
4	USBM_GPIOA1	Output Low
5	USBM_GPIOA2	Output Low
6	USBM_GPIOA3	Output Low
7	USBM_GPIOA5	Output Low
8	USBM_GPIOA6	Output Low
9	USBM_GPIOA7	Output Low
10	USBM_GPIOA8	Output Low
11	USBM_GPIOB0	Output Low
12	USBM_GPIOB1	Output Low
13	USBM_GPIOB2	Output Low
14	USBM_GPIOB3	Output Low
15	USBM_GPIOB4	Output Low
16	USBM_GPIOB5	Output Low
17	USBM_GPIOB6	Output Low

18	USBM_GPIOB7	Output Low
19	GND	-
20	GND	-
21	USBM_GPIOC0	Input
22	USBM_GPIOC1	Input
23	USBM_GPIOC2	Input
24	USBM_GPIOC3	Input
25	USBM_GPIOC4	Multi Function for UART0_TX
26	USBM_GPIOC5	Multi Function for UART0_RX
27	USBM_GPIOC6	Input
28	USBM_GPIOC7	Output low for Power LED
29	USBM_GPIOD0	Input
30	USBM_GPIOD1	Input
31	USBM_GPIOD2	Input
32	USBM_GPIOD3	Input
33	USBM_GPIOD4	Input
34	USBM_GPIOD5	Input
35	USBM_GPIOD6	Input
36	USBM_GPIOD7	Input
37	GND	-

■ COM#1 / COM#2 / COM#3 / COM#4

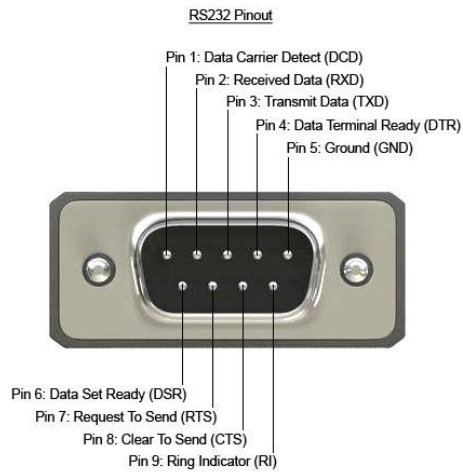

Pin	PWR RS232	RS232	RS422	RS485
1	DCD	DCD	TX- [TX(B)]	RS485 D-(B)
2	RX	RX	TX+ [TX(A)]	RS485 D+(A)
3	RTX	RTX	RX+ [RX(A)]	NC
4	DTR	DTR	RX- [RX(B)]	NC
5	GND	GND	GND	GND
6	DSR	DSR	NC	NC
7	RTS	RTS	NC	NC
8	CTS	CST	NC	NC
9	5V/12V	RI	NC	NC

■ 2.5"/3.5" HDD Tray Switch

Power on/off switch for left 2.5"/3.5" HDD Tray or right 2.5"/3.5" HDD Tray.

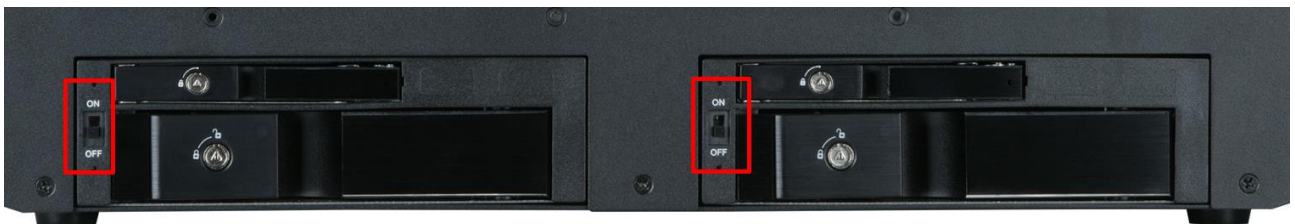

2.5 Expansion Module MS-01IGN-S10

This Module MS-01IGN-S10 can detect vehicle ignition status and control the on/off delay time setting. This document is used to guide how to set up this power ignition module correctly.

a. Location

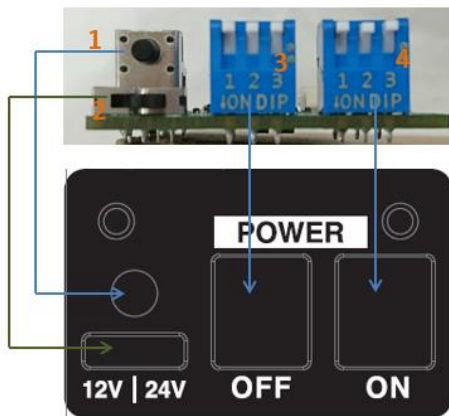

- (1) Emergency reset button
- (2) Input power selection switch
- (3) Power off delay switch
- (4) Power on delay switch

b. Function

✓ **Emergency reset button**

This button is for engineering use only. The host will be reset when this button is pressed.

✓ **Input power selection switch**

Common car power supplies are DC 12V or 24V. Please set it according to your environment.

c. Delay Power On/Off Setting Switch

This feature detects the ignition signal status and allows users to control the on/off delay time setting through DIP switch.

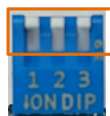

set on up side = 0



set on down side = 1

Power Off Delay Time Table

1	2	3	
0	0	0	0 second
0	0	1	1 minute
0	1	0	3 minutes
0	1	1	5 minutes
1	0	0	10 minutes
1	0	1	30 minutes
1	1	0	1 hour
1	1	1	2 hours

Power On Delay Time Table

1	2	3	
0	0	0	0 second
0	0	1	3 seconds
0	1	0	4 seconds
0	1	1	10 seconds
1	0	0	15 seconds
1	0	1	20 seconds
1	1	0	25 second
1	1	1	30 seconds

SYSTEM SETUP

This chapter provides information about how to set up the XM1 Rugged GPU Computing System hardware installation.

3

CHAPTER 3: SYSTEM SETUP

This chapter provides information about how to set up the XM1 Rugged GPU Computing System hardware installation.

3.1 CPU, Memory, and M.2 M Key Module Installation

Please follow the instructions to install CPU & memory as below.

- Loosen 7 screws to release heatsink front cover



- Loosen 8 screws for heatsink



- Remove black mylar and CPU socket cover, and follow CPU direction to install CPU.



- Assemble SO-DIMM DDR5 memory to slots



- Assemble M.2 M key/B-M key module to M.2 M key slot

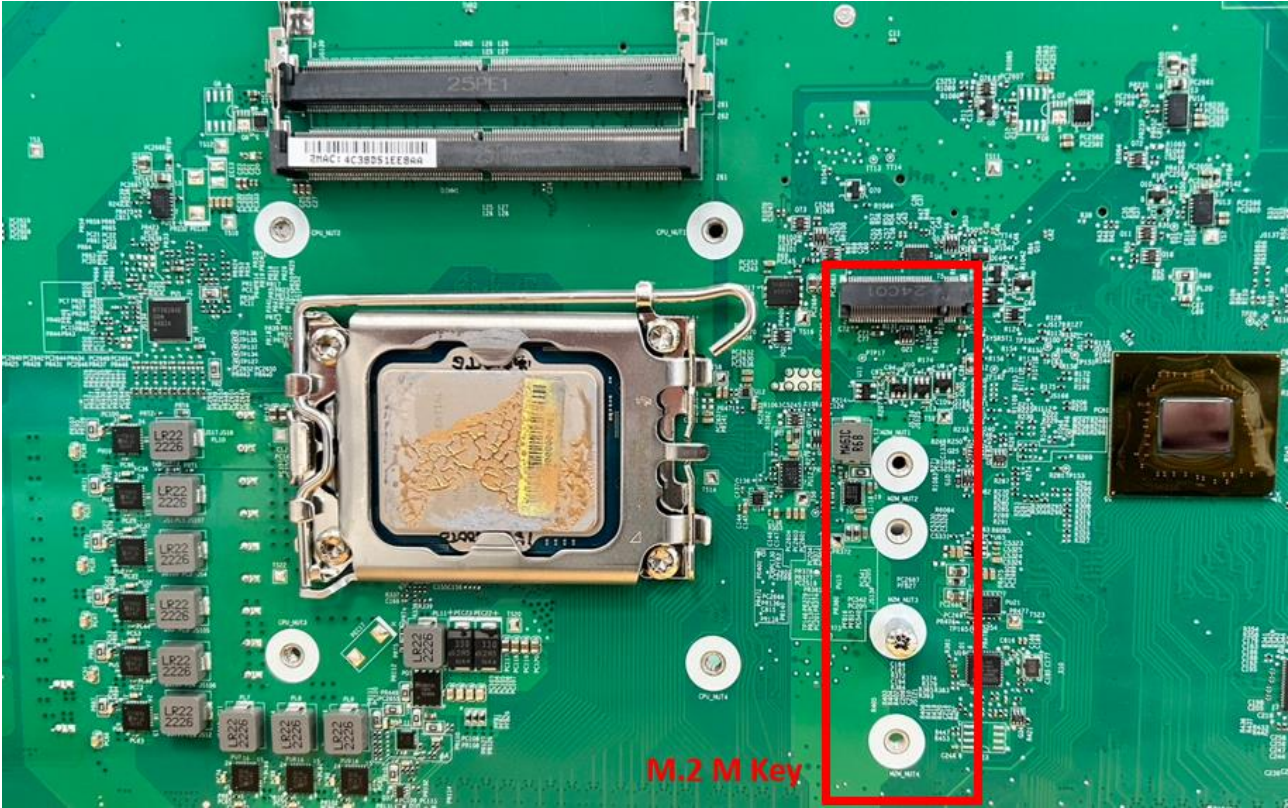

M.2 M Key

3.2 M.2 B Key/E Key/mPCIe Module Installation

- Loosen 7 screws, and move chassis cover as below direction



- Assemble M.2 B key/E key/mPCIe module as below location on the bottom of main board

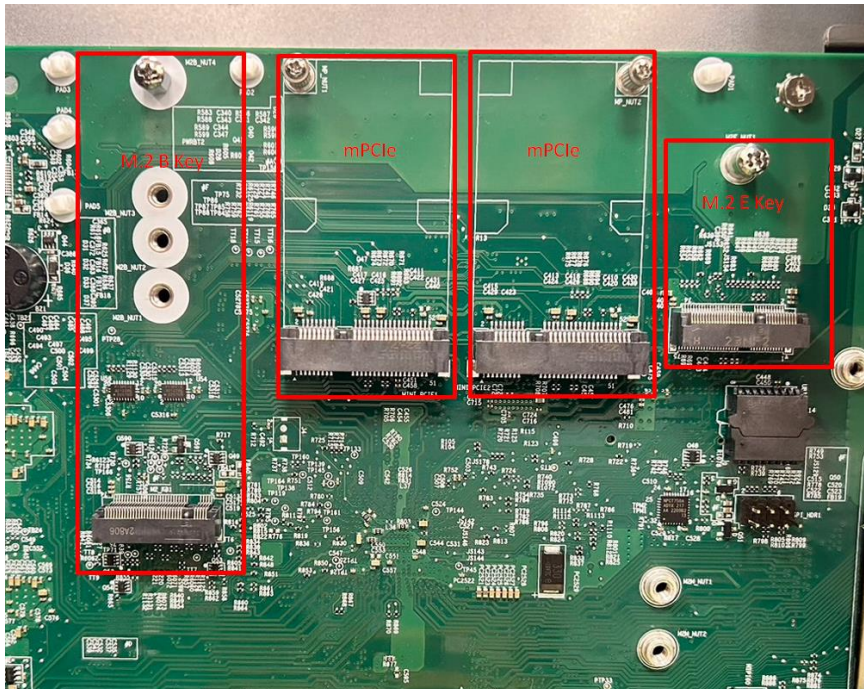

3.3 PCIe Card Installation

- Loosen 4 screws to release PCIe card holder bracket as red box highlights
- After PCIe card assembly, please adjust bumpers in blue box A to hold PCIe card in Slot#1, and bumpers in blue box B to hold PCIe card in Slot#2 in place

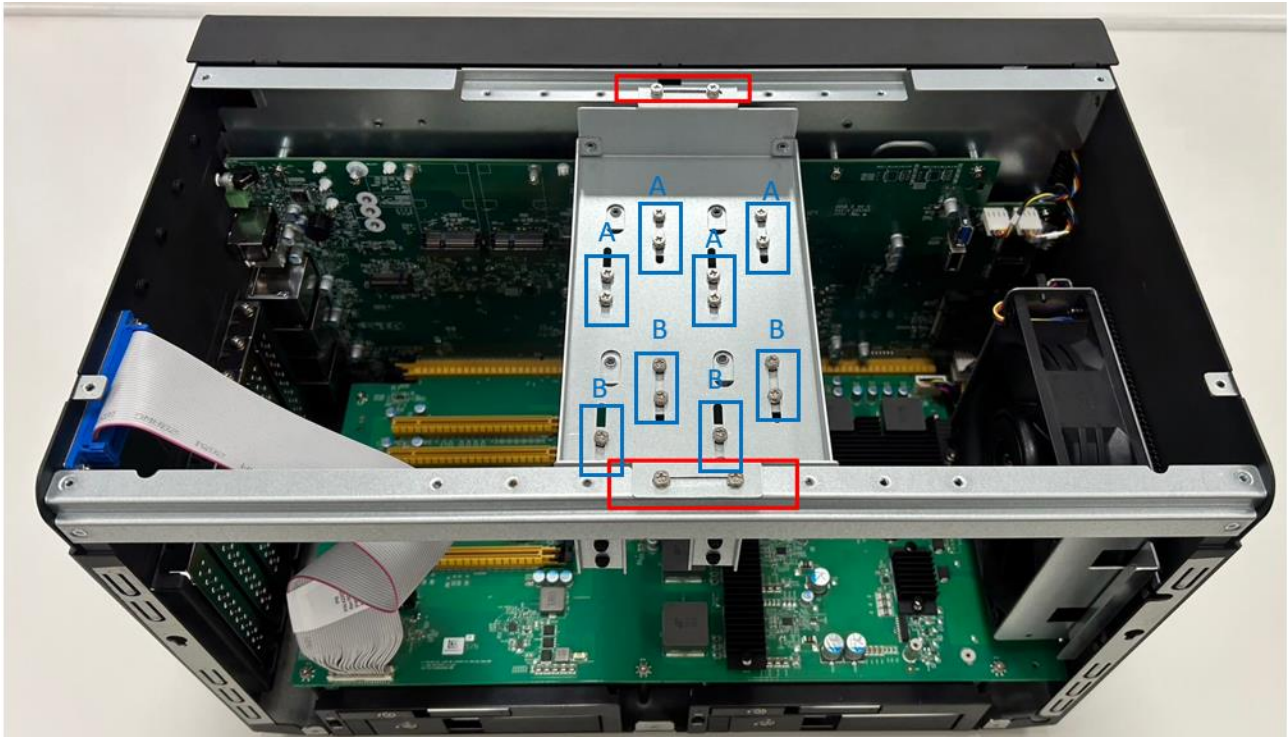

- Loosen 1 screw for PCIe door plate which will be used for expansion card and assemble with PCIe card bracket. Then adjust PCIe card holder to fix the card to resist S&V conditions

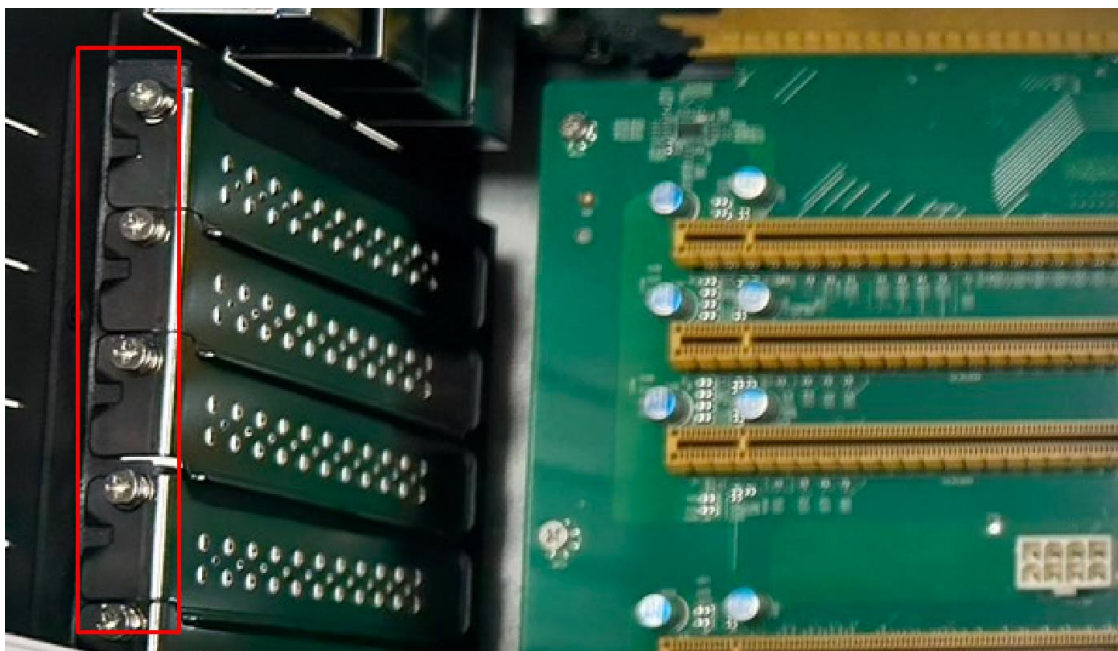

3.4 RTC Battery Maintenance

- Preparation for disassembly:

Flathead Screwdriver

(The battery holder is designed for great vibration resistant and harsh environment use, so it needs to use a tool to disassemble the coin battery)

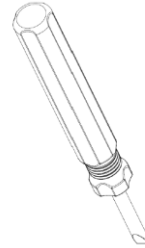

- Insert flathead screwdriver to the gap of one side of RTC battery vertically.
- Rotate the screwdriver at around 45 degrees to loosen the coin battery

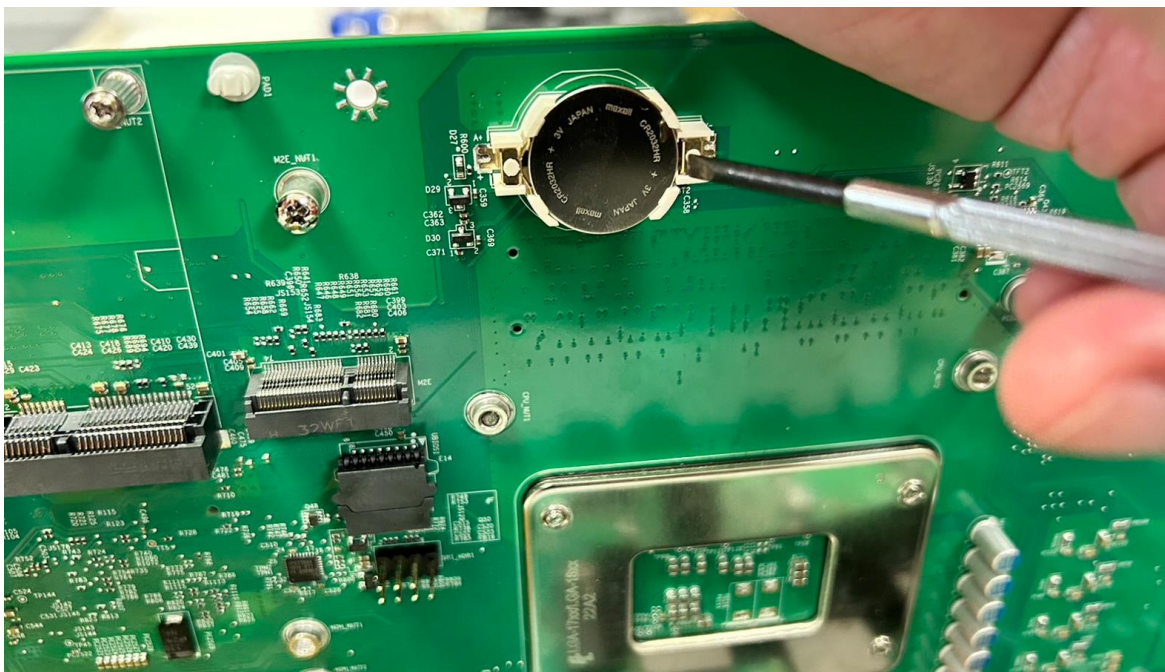

3.5 1000W PSU Cable Assembly

- Green, white, and black cables connect to power cords. Red and black cables connect to XM1 terminal block connectors.

***Only experienced electronics personnel should open the PC chassis, or assemble the power supply with power cable connection.**



- Black cables connect to GND, and red cables connect to V+.

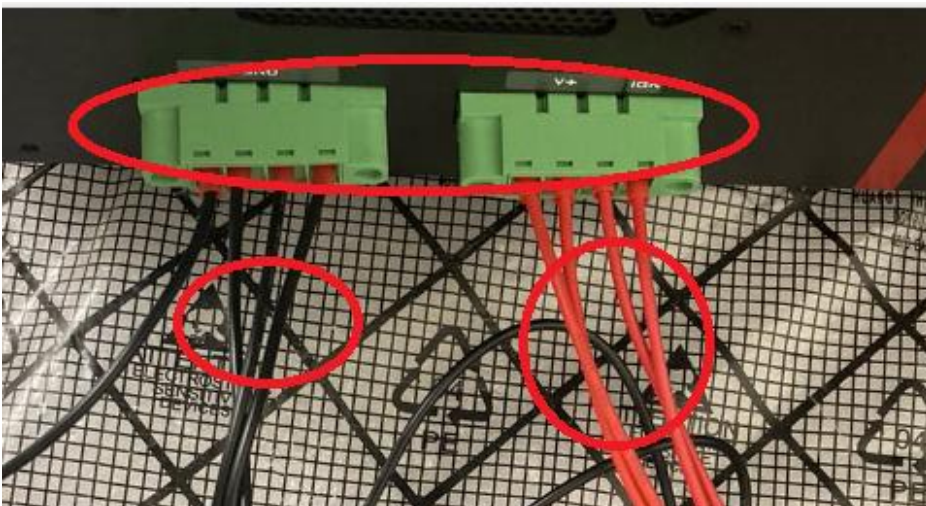

BIOS SETUP

This chapter provides information about how to set up BIOS and use BIOS menu items to adjust basic function settings.

4

CHAPTER 4: BIOS SETUP

This chapter provides information about how to set up BIOS and use BIOS menu items to adjust basic function settings.

4.1 Main Page

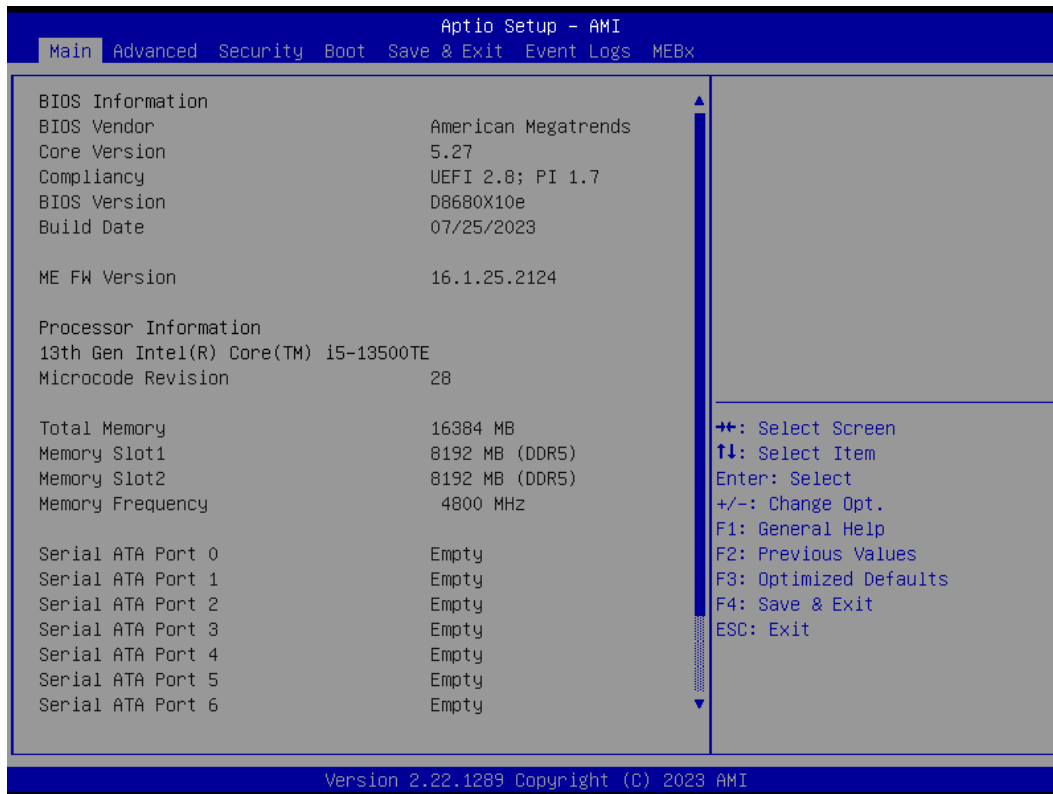

Field Name	BIOS Vender
Default Value	American Megatrends
Comment	This field is not selectable. There is no help text associated with it.

Field Name	Core Version
Default Value	5.27
Comment	This field is not selectable. There is no help text associated with it.

Field Name	Compliance
Default Value	UEFI 2.8 ; PI 1.7
Comment	This field is not selectable. There is no help text associated with it.

Field Name	BIOS Version
Default Value	Display the version of the BIOS
Comment	This field is not selectable. There is no help text associated with it.

Field Name	Build Date
Default Value	Display build date of the BIOS
Comment	This field is not selectable. There is no help text associated with it.

Field Name	ME FW Version
------------	----------------------

Value	ME Firmware Version.
Comment	This field is not selectable. There is no help text associated with it.

Field Name	Processor Information
Value	Display the installed CPU brand.
Comment	This field is not selectable. There is no help text associated with it.

Field Name	Microcode Revision
Value	Display the CPU microcode revision.
Comment	This field is not selectable. There is no help text associated with it.

Field Name	Total Memory
Value	Display the installed memory size.
Comment	This field is not selectable. There is no help text associated with it.

Field Name	Memory Slot1
Value	Display the installed memory size of slot1.
Comment	This field is not selectable. There is no help text associated with it.

Field Name	Memory Slot2
Value	Display the installed memory size of slot2.
Comment	This field is not selectable. There is no help text associated with it.

Field Name	Memory Frequency
Value	Display the installed memory frequency.
Comment	This field is not selectable. There is no help text associated with it.

Field Name	Serial ATA Port 0
Value	Display the installed SATA device model/size of port 0.
Comment	This field is not selectable. There is no help text associated with it.

Field Name	Serial ATA Port 1
Value	Display the installed SATA device model/size of port 1.
Comment	This field is not selectable. There is no help text associated with it.

Field Name	Serial ATA Port 2
Value	Display the installed SATA device model/size of port 2.
Comment	This field is not selectable. There is no help text associated with it.

Field Name	Serial ATA Port 3
Value	Display the installed SATA device model/size of port 3.
Comment	This field is not selectable. There is no help text associated with it.

Field Name	Serial ATA Port 4
Value	Display the installed SATA device model/size of port 4.
Comment	This field is not selectable. There is no help text associated with it.

Field Name	Serial ATA Port 5
Value	Display the installed SATA device model/size of port 5.
Comment	This field is not selectable. There is no help text associated with it.

Field Name	Serial ATA Port 6
Value	Display the installed SATA device model/size of port 6.
Comment	This field is not selectable. There is no help text associated with it.

Field Name	Serial ATA Port 7
Value	Display the installed SATA device model/size of port 7.

Comment	This field is not selectable. There is no help text associated with it.
---------	---

Field Name	System Date
Default Value	[Www mm/dd/yyyy]
Possible Value	Www : Mon/Tue/Wed/Thu/Fri/Sat/Sun mm : 1-12 dd : 1-31 yyyy : 1900-9999
Help	Set the Date. Use Tab to switch between Date elements. Default Ranger: Year : 1900-9999 Months : 1-12 Days : Dependent on month Range of Years may vary.

Field Name	System Time
Default Value	[hh :mm :ss]
Possible Value	hh : 0-23 mm : 0-59 ss : 0-59
Help	Set the Time. Use Tab to switch between Time elements.

4.2 Advance Page

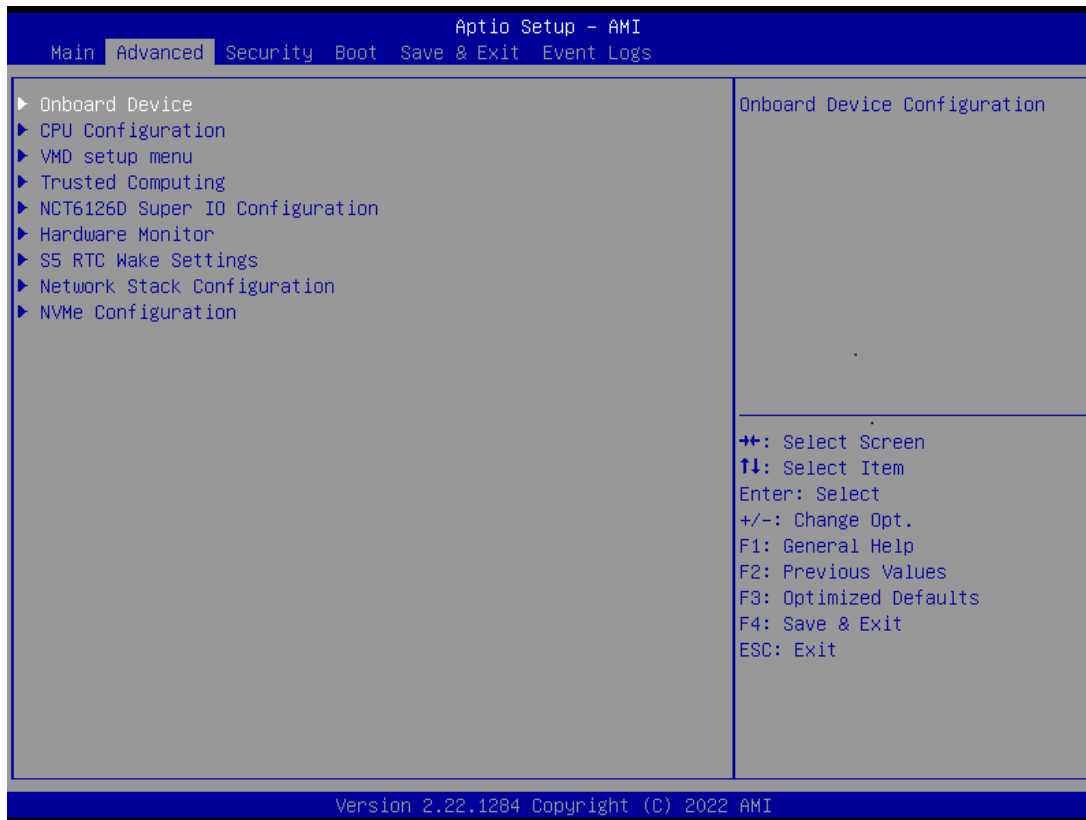

Field Name	Onboard Device
Help	Onboard Device Configuration.
Comment	Press Enter when selected to go into the associated Sub-Menu.

Field Name	CPU Configuration
Help	CPU Configuration Parameters.
Comment	Press Enter when selected to go into the associated Sub-Menu.

Field Name	VMD setup menu
Help	VMD Configuration settings
Comment	Press Enter when selected to go into the associated Sub-Menu.

Field Name	Trusted Computing
Help	Trusted Computing Settings
Comment	Press Enter when selected to go into the associated Sub-Menu.

Field Name	NCT6126D Super IO Configuration
Help	System Super IO Chip Parameters.
Comment	Press Enter when selected to go into the associated Sub-Menu.

Field Name	Hardware Monitor
Help	Monitor hardware status
Comment	Press Enter when selected to go into the associated Sub-Menu.

Field Name	S5 RTC Wake Settings
Help	Enable system to wake from S5 using RTC alarm
Comment	Press Enter when selected to go into the associated Sub-Menu.

Field Name	Network Stack Configuration
Help	Network Stack Settings.
Comment	Press Enter when selected to go into the associated Sub-Menu.

Field Name	NVMe Configuration
Help	NVMe Device Options Settings
Comment	Press Enter when selected to go into the associated Sub-Menu.

4.2.1 Onboard Device

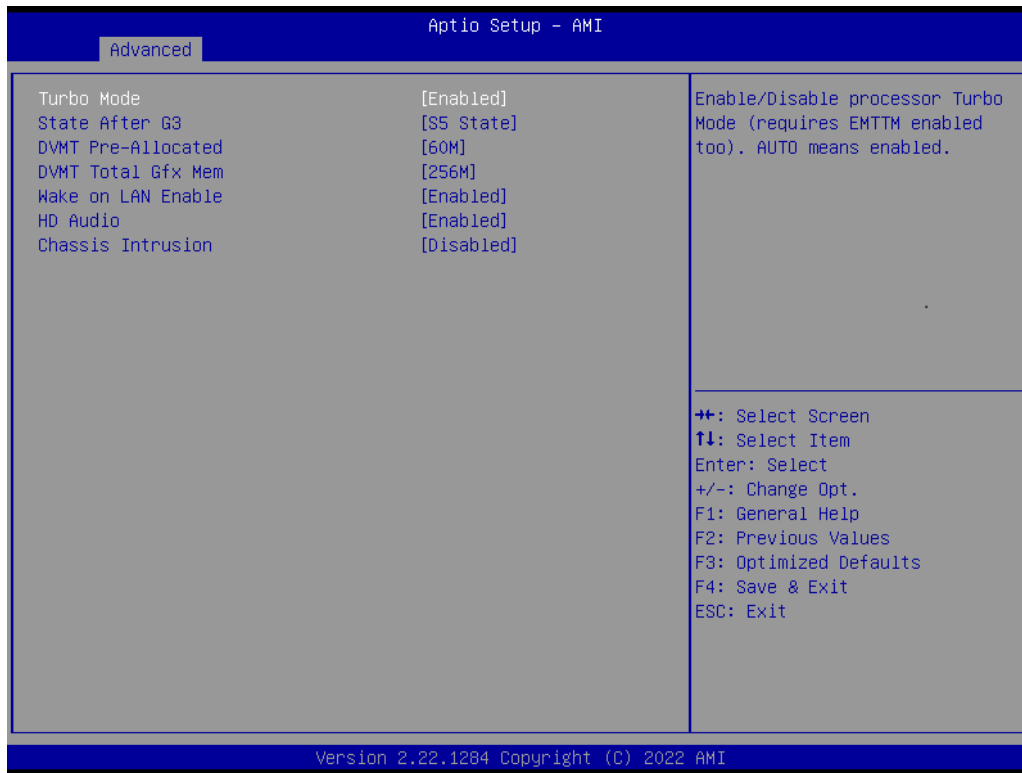

Field Name	Turbo Mode
Default Value	[Enabled]
Possible Value	Enabled Disabled
Help	Enable/Disable processor Turbo Mode (requires EMTTM enabled too).AUTO means enabled.

Field Name	State After G3
Default Value	[S5 State]
Possible Value	S0 State S5 State
Help	Specify what state to go to when power is re-applied after a power failure (G3 state).

Field Name	DVMT Pre-Allocated
Default Value	[60M]
Possible Value	64M 32M/F7 36M 40M 44M 48M 52M 56M 60M
Help	Select DVMT 5.0 Pre-Allocated (Fixed) Graphics Memory size used by the Internal Graphics Device.

Field Name	DVMT Total Gfx Mem
------------	---------------------------

Default Value	[256M]
Possible Value	128M 256M MAX
Help	Select DVMT5.0 Total Graphic Memory size used by the Internal Graphics Device.

Field Name	HD Audio
Default Value	[Enabled]
Possible Value	Enabled Disabled
Help	Control Detection of the HD-Audio device. Disabled = HDA will be unconditionally disabled Enabled = HDA will be unconditionally enabled.

Field Name	M2 key BSIM card switch
Default Value	[M2B SIM1]
Possible Value	M2B SIM2 M2B SIM1
Help	M2 key B SIM card Switch function

Field Name	Mini PCIe SIM card switch
Default Value	[MPE SIM1_ MPE2 SIM2]
Possible Value	MPE1 SIM2_ MEP2 SIM1 MPE1 SIM1_ MEP2 SIM2
Help	Mini PCIe SIM card Switch function MPE SIM1_ MPE2 SIM2 MP1->MPE SIM1 MP2->MPE SIM2 MPE SIM2_ MPE2 SIM1 MP1->MPE SIM2 MP2->MPE SIM1

4.2.2 CPU Configuration

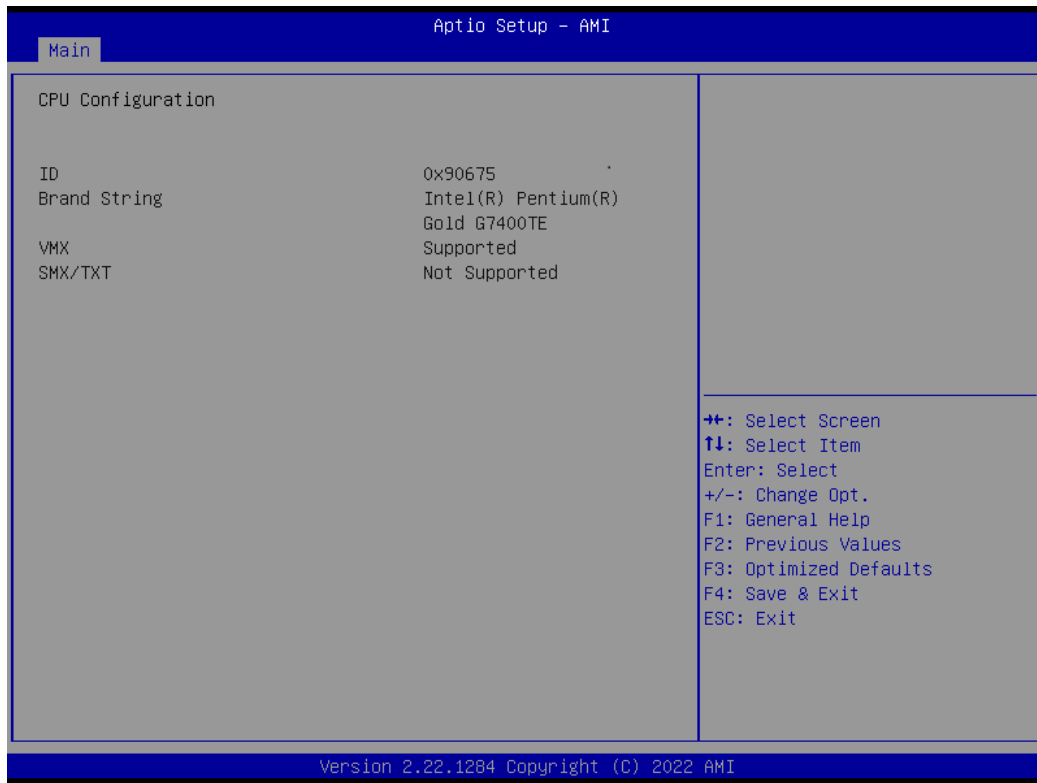

Field Name	ID
Default Value	Displays CPU Signature
Comment	This field is not selectable. There is no help text associated with it.

Field Name	Brand String
Default Value	Displays the CPU brand string
Comment	This field is not selectable. There is no help text associated with it.

Field Name	VMX
Default Value	VMX Supported or Not
Comment	This field is not selectable. There is no help text associated with it.

Field Name	SMX/TXT
Default Value	SMX/TXT Supported or Not
Comment	This field is not selectable. There is no help text associated with it.

4.2.3 VMD Setup Menu

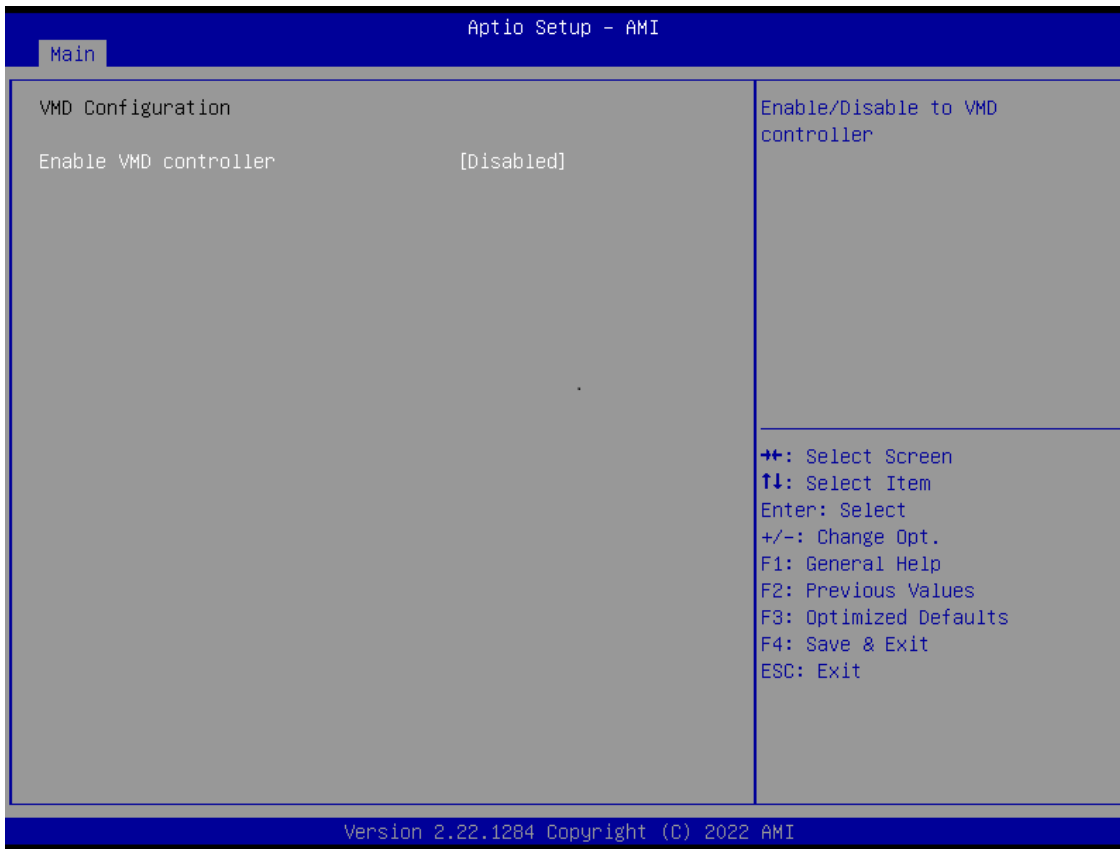

Field Name	VMD Configuration
Default Value	VMD Configuration.
Comment	This field is not selectable. There is no help text associated with it.

Field Name	Enable VMD controller
Default Value	[Disabled]
Possible Value	Disabled Enabled
Help	Enable/Disable to VMD controller.

4.2.4 Trusted Computing



Field Name	Firmware Version
Default Value	TPM module version.
Comment	This field is not selectable. There is no help text associated with it.

Field Name	Vendor
Default Value	TPM module vendor name.
Comment	This field is not selectable. There is no help text associated with it.

Field Name	Security Device Support
Default Value	[Enable]
Possible Value	Enable Disable
Help	Enables or Disables BIOS support for security device. O.S. will not show Security Device. TCG EFI protocol and INT1A interface will not be available.

Field Name	Pending operation
Default Value	[None]
Possible Value	None TPM Clear
Help	Schedule an Operation for the Security Device. NOTE: Your Computer will reboot during restart in order to change State of Security Device.

4.2.5 Super IO Configuration

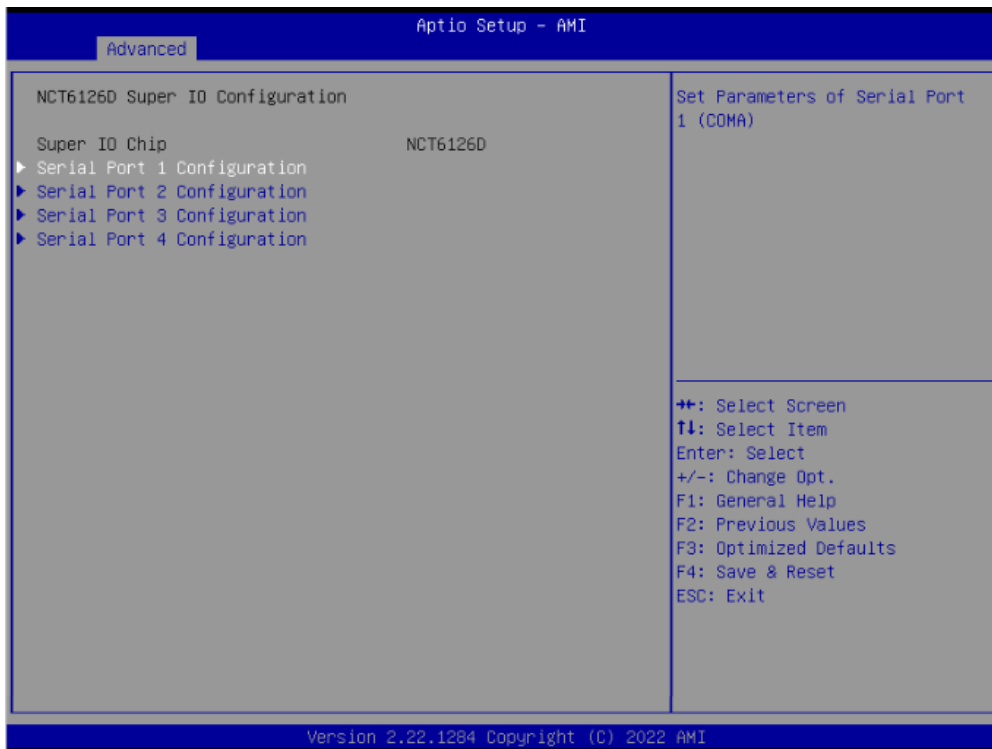

Field Name	Serial Port 1 Configuration
Help	Set Parameters of Serial Port 1 (COMA)
Comment	Press Enter when selected to go into the associated Sub-Menu.

Field Name	Serial Port 2 Configuration
Help	Set Parameters of Serial Port 2 (COMB)
Comment	Press Enter when selected to go into the associated Sub-Menu.

Field Name	Serial Port 3 Configuration
Help	Set Parameters of Serial Port 3 (COMC)
Comment	Press Enter when selected to go into the associated Sub-Menu.

Field Name	Serial Port 4 Configuration
Help	Set Parameters of Serial Port 4 (COMD)
Comment	Press Enter when selected to go into the associated Sub-Menu.

4.2.5.1 Serial Port 1 Configuration

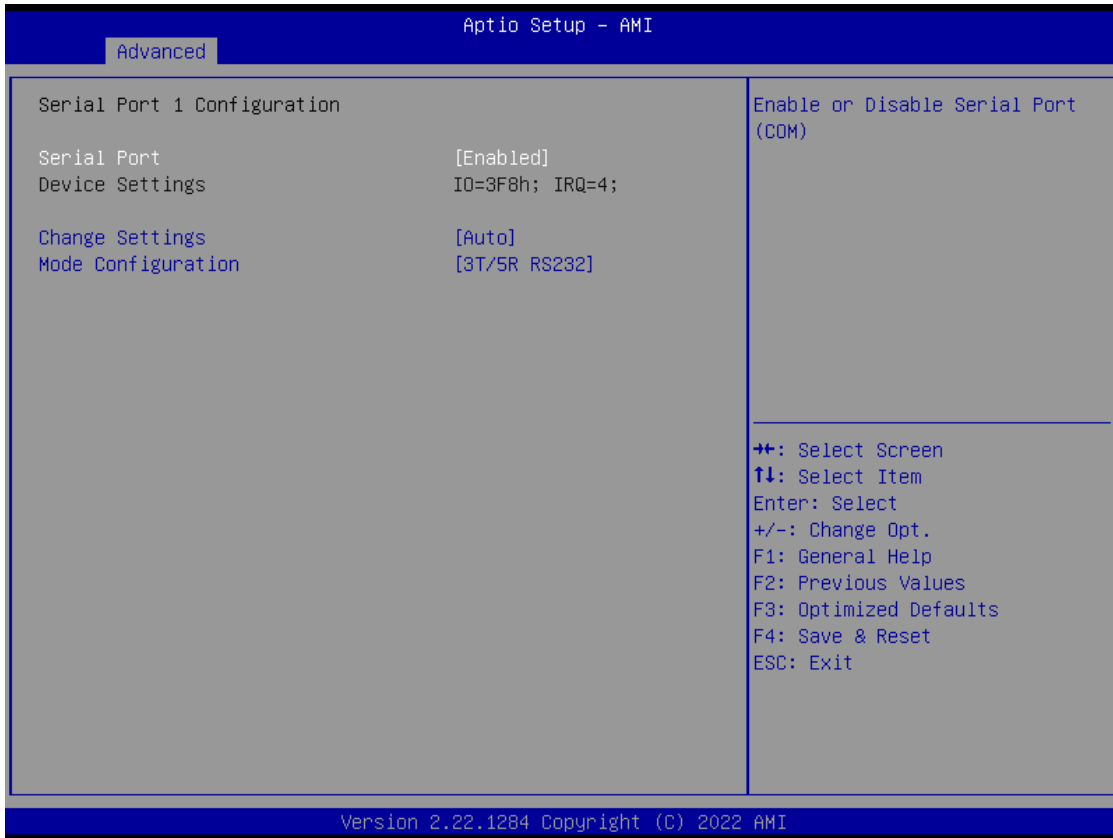

Field Name	Serial Port
Default Value	[Enabled]
Possible Value	Disabled Enabled
Help	Enable or Disable Serial Port(COM)

Field Name	Device Settings
Default Value	Device Super IO COM1 Address and IRQ.
Comment	This field is not selectable. There is no help text associated with it.

Field Name	Change Settings
Default Value	[Auto]
Possible Value	Auto IO=3F8h; IRQ=4; IO=3F8h; IRQ=3,4,5,6,7,9,10,11,12; IO=2F8h; IRQ=3,4,5,6,7,9,10,11,12; IO=3E8h; IRQ=3,4,5,6,7,9,10,11,12; IO=2E8h; IRQ=3,4,5,6,7,9,10,11,12;
Help	Select an optimal settings for Super IO Device

Field Name	Mode Configuration
Default Value	[3T/5R RS232]
Possible Value	1T/1R RS422 3T/5R RS232 1T/1R RS485 TX ENABLE Low Active 1T/1R RS422 with termination resistor

	1T/1R RS485 with termination resistor TX ENABLE Low Active Disabled
Help	Configure serial port as RS232/RS422/RS485.

4.2.5.2 Serial Port 2 Configuration



Field Name	Serial Port
Default Value	[Enabled]
Possible Value	Disabled Enabled
Help	Enable or Disable Serial Port(COM)

Field Name	Device Settings
Default Value	Device Super IO COM2 Address and IRQ.
Comment	This field is not selectable. There is no help text associated with it.

Field Name	Change Settings
Default Value	[Auto]
Possible Value	Auto IO=2F8h; IRQ=3; IO=3F8h; IRQ=3,4,5,6,7,9,10,11,12; IO=2F8h; IRQ=3,4,5,6,7,9,10,11,12; IO=3E8h; IRQ=3,4,5,6,7,9,10,11,12; IO=2E8h; IRQ=3,4,5,6,7,9,10,11,12;
Help	Select an optimal settings for Super IO Device

4.2.5.3 Serial Port 3 Configuration

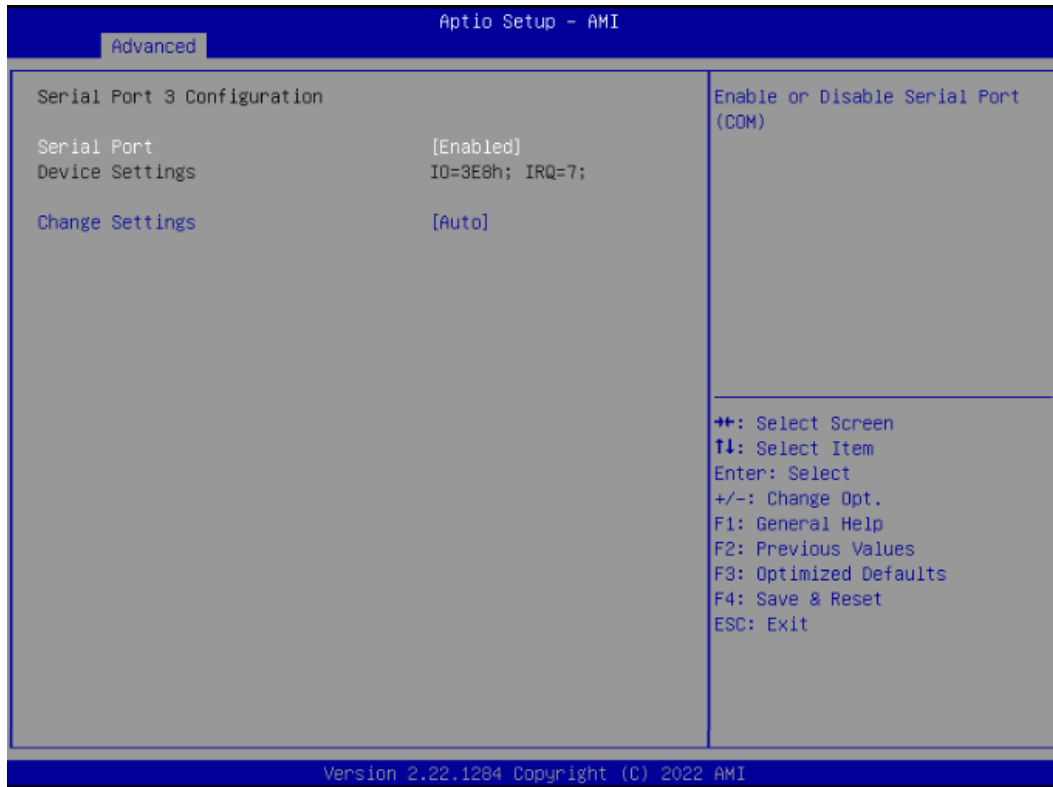

Field Name	Serial Port
Default Value	[Enabled]
Possible Value	Disabled Enabled
Help	Enable or Disable Serial Port(COM)

Field Name	Device Settings
Default Value	Device Super IO COM3 Address and IRQ.
Comment	This field is not selectable. There is no help text associated with it.

Field Name	Change Settings
Default Value	[Auto]
Possible Value	Auto IO=3E8h; IRQ=7; IO=3E8h; IRQ=3,4,5,6,7,9,10,11,12; IO=2E8h; IRQ=3,4,5,6,7,9,10,11,12; IO=220h; IRQ=3,4,5,6,7,9,10,11,12; IO=228h; IRQ=3,4,5,6,7,9,10,11,12;
Help	Select an optimal settings for Super IO Device

4.2.5.4 Serial Port 4 Configuration

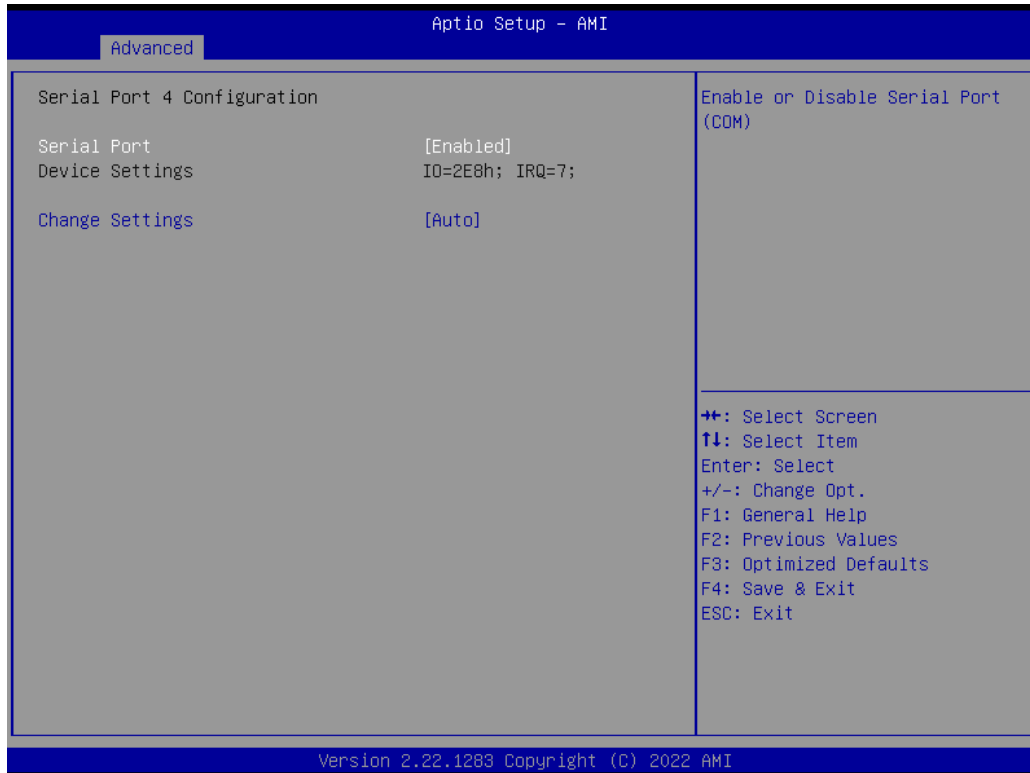

Field Name	Serial Port
Default Value	[Enabled]
Possible Value	Disabled Enabled
Help	Enable or Disable Serial Port(COM)

Field Name	Device Settings
Default Value	Device Super IO COM4 Address and IRQ.
Comment	This field is not selectable. There is no help text associated with it.

Field Name	Change Settings
Default Value	[Auto]
Possible Value	Auto IO=2E8h; IRQ=12; IO=3E8h; IRQ=3,4,5,6,7,9,10,11,12; IO=2E8h; IRQ=3,4,5,6,7,9,10,11,12; IO=220h; IRQ=3,4,5,6,7,9,10,11,12; IO=228h; IRQ=3,4,5,6,7,9,10,11,12;
Help	Select an optimal settings for Super IO Device

4.2.6 Hardware Monitor

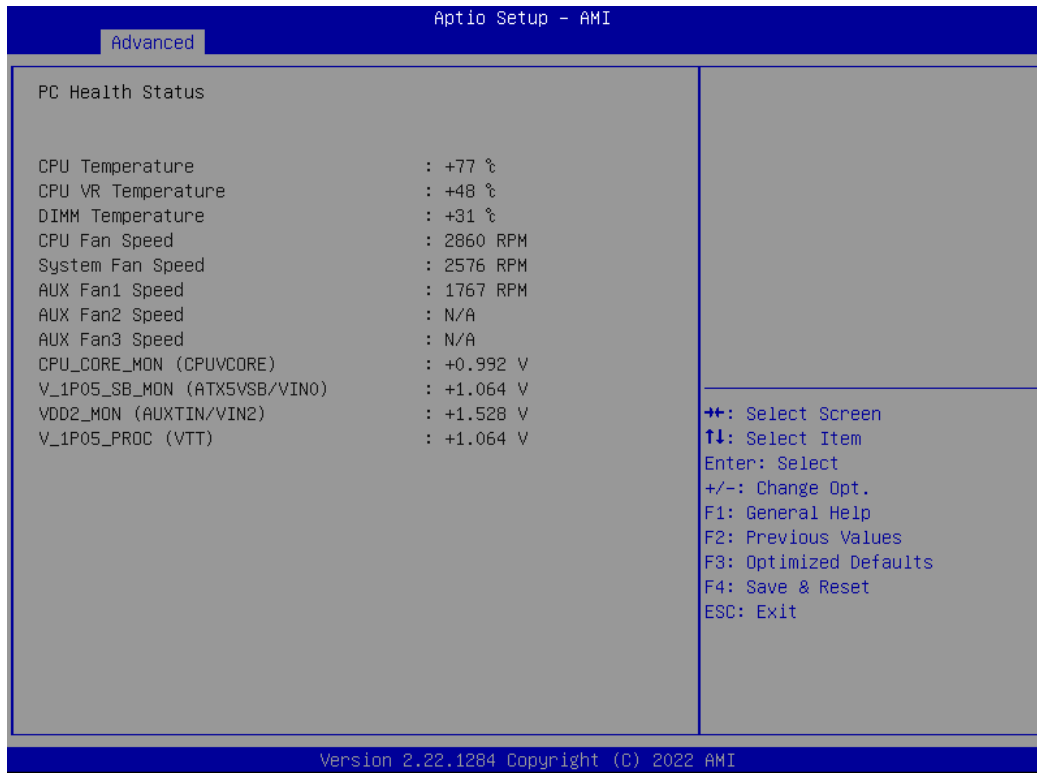

Type	Range
CPU Temperature	-20 ~ (By Processor Tjmax) °C
CPU VR Temperature	-20 ~ 120 °C
DIMM Temperature	-20 ~ 120 °C
CPU Fan Speed	There are many kinds of the fan could be installed into the system, so we could only set 0 RPM for the failed fan speed, and there is also no high RPM limitation.
System Fan Speed	
AUX Fan1 Speed	
AUX Fan2 Speed	
AUX Fan3 Speed	
CPU_CORE_MON	0~1.72V
V_1P05_SB_MON	0~1.575V
VDD2_MON	0~1.575V
V_1P05_PROC	0.9975~1.1025V

4.2.7 S5 RTC Wake Setting



Field Name	Wake system from S5
Default Value	[Disabled]
Possible Value	Disabled Fixed Time
Help	Enable or disable System wake on alarm event. Select FixedTime, system will wake on the hr::min::sec specified.

Field Name	Wake up hour(Show when Wake system from S5 set to Fixed Time)
Default Value	0
Possible Value	0-23
Help	select 0-23 For example enter 3 for 3am and 15 for 3pm

Field Name	Wake up minute(Show when Wake system from S5 set to Fixed Time)
Default Value	0
Possible Value	0-59
Help	select 0 – 59 for Minute

Field Name	Wake up second(Show when Wake system from S5 set to Fixed Time)
Default Value	0
Possible Value	0 - 59
Help	select 0 – 59 for Second

4.2.8 Network Stack Configuration



Field Name	Network Stack
Default Value	[Disabled]
Possible Value	Disabled Enabled
Help	Enable/Disable UEFI Network Stack.

Field Name	IPv4 PXE Support (Available when Network stack Enabled)
Default Value	[Disabled]
Possible Value	Disabled Enabled
Help	Enable/Disable IPv4 PXE boot support. If disabled, IPv4 PXE boot support will not be available.

Field Name	IPv6 PXE Support (Available when Network stack Enabled)
Default Value	[Disabled]
Possible Value	Disabled Enabled
Help	Enable/Disable IPv6 PXE boot support. If disabled, IPv6 PXE boot support will not be available.

4.2.9 NVMe Configuration



Field Name	(Device)
Comment	Press Enter when selected to go into the associated Sub-Menu.

4.3 Security Page



Field Name	Administrator Password
Help	Set Administrator Password

Field Name	User Password
Help	Set User Password.

Field Name	HDD Security drive
Help	HDD Security Configuration for selected drive
Comment	Press Enter when selected to go into the associated Sub-Menu.

Field Name	Secure Boot
Help	Secure Boot configuration
Comment	Press Enter when selected to go into the associated Sub-Menu.

Field Name	BIOS Update
Help	BIOS Update support
Comment	Press Enter when selected to go into the associated Sub-Menu.

4.3.1 HDD Security

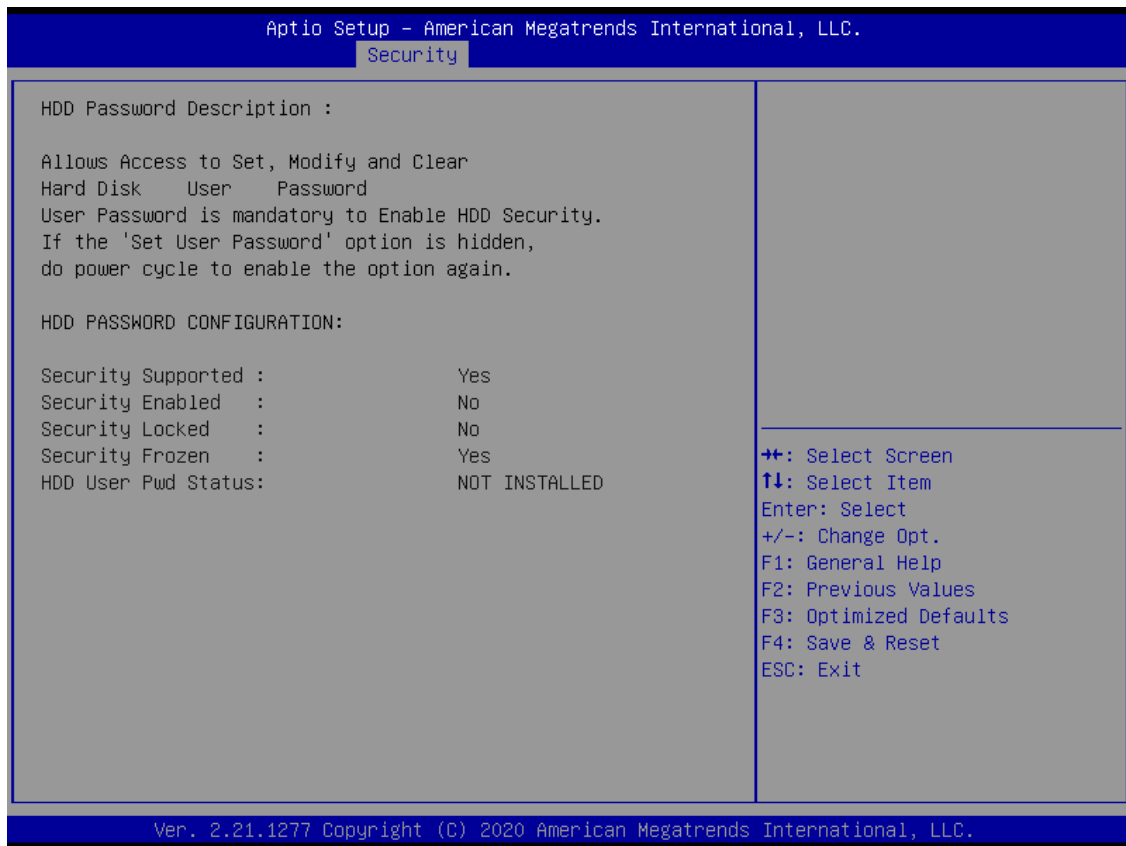

Field Name	Set User Password
Help	Set HDD User Password. *** Advisable to Power Cycle System after Setting Hard Disk Passwords ***.Discard or Save changes option in setup does not have any impact on HDD when password is set or removed. If the 'Set HDD User Password' option is hidden, do power cycle to enable the option again

4.3.2 Secure Boot

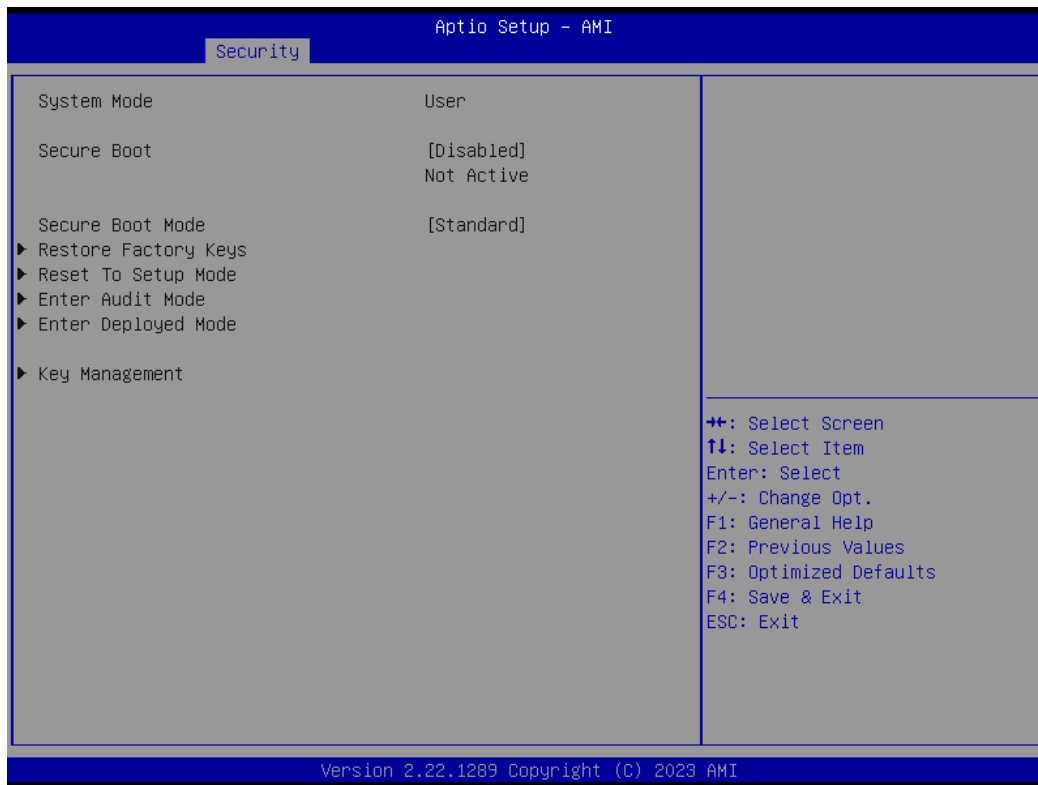

Field Name	Secure Boot
Default Value	[Enabled]
Possible Value	Enabled Disabled
Help	Secure Boot feature is Active if Secure Boot is Enabled, Platform Key(PK) is enrolled and the System is in User mode. The mode change requires platform reset

Field Name	Secure Boot Mode
Default Value	[Standard]
Possible Value	Standard Custom
Help	Secure Boot mode options: Standard or Custom. In Custom mode, Secure Boot Policy variables can be configured by a physically present user without full authentication

Field Name	Restore Factory Keys
Help	Force System to User Mode. Install factory default Secure Boot key databases

Field Name	Reset To Setup Mode
Help	Delete all Secure Boot key databases from NVRAM

Field Name	Enter Audit Mode
Help	Enter Audit Mode workflow. Transitions from User to Audit Mode will result in erasing of PK variable
Comment	Enter Audit Mode workflow. Transitions from User to Audit Mode will result in erasing of PK variable

Field Name	Platform Key (PK)
Default Value	Size:0, Keys:0, Key source: No Keys
Help	Enroll Factory Defaults or load certificates from a file: 1.Public Key Certificate: a)EFI_SIGNATURE_LIST b)EFI_CERT_X509 (DER) c)EFI_CERT_RSA2048 (bin) d)EFI_CERT_SHAXXX 2.Authenticated UEFI Variable 3.EFI PE/COFF Image(SHA256) Key Source: Factory,External,Mixed
comment	Press Enter when selected to go into the associated Sub-Menu “Key Management”.

Field Name	Key Exchange Keys (KEK)
Default Value	Size:0, Keys:0, Key source: No Keys
Help	Enroll Factory Defaults or load certificates from a file: 1.Public Key Certificate: a)EFI_SIGNATURE_LIST b)EFI_CERT_X509 (DER) c)EFI_CERT_RSA2048 (bin) d)EFI_CERT_SHAXXX 2.Authenticated UEFI Variable 3.EFI PE/COFF Image(SHA256) Key Source: Factory,External,Mixed
comment	Press Enter when selected to go into the associated Sub-Menu.

Field Name	Authorized Signatures (db)
Default Value	Size:0, Keys:0, Key source: No Keys
Help	Enroll Factory Defaults or load certificates from a file: 1.Public Key Certificate: a)EFI_SIGNATURE_LIST b)EFI_CERT_X509 (DER) c)EFI_CERT_RSA2048 (bin) d)EFI_CERT_SHAXXX 2.Authenticated UEFI Variable 3.EFI PE/COFF Image(SHA256) Key Source: Factory,External,Mixed
comment	Press Enter when selected to go into the associated Sub-Menu.

Field Name	Forbidden Signatures(dbx)
Default Value	Size:0, Keys:0, Key source: No Keys
Help	Enroll Factory Defaults or load certificates from a file: 1.Public Key Certificate: a)EFI_SIGNATURE_LIST b)EFI_CERT_X509 (DER) c)EFI_CERT_RSA2048 (bin) d)EFI_CERT_SHAXXX 2.Authenticated UEFI Variable 3.EFI PE/COFF Image(SHA256) Key Source: Factory,External,Mixed
comment	Press Enter when selected to go into the associated Sub-Menu.

Field Name	Authorized TimeStamps(dbt)
Default Value	Size:0, Keys:0, Key source: No Keys
Help	Enroll Factory Defaults or load certificates from a file: 1.Public Key Certificate: a)EFI_SIGNATURE_LIST b)EFI_CERT_X509 (DER) c)EFI_CERT_RSA2048 (bin) d)EFI_CERT_SHAXXX 2.Authenticated UEFI Variable 3.EFI PE/COFF Image(SHA256) Key Source: Factory,External,Mixed
comment	Press Enter when selected to go into the associated Sub-Menu.

Field Name	OsRecovery Signatures (dbr)
Default Value	Size:0, Keys:0, Key source: No Keys
Help	Enroll Factory Defaults or load certificates from a file: 1.Public Key Certificate: a)EFI_SIGNATURE_LIST b)EFI_CERT_X509 (DER) c)EFI_CERT_RSA2048 (bin) d)EFI_CERT_SHAXXX 2.Authenticated UEFI Variable 3.EFI PE/COFF Image(SHA256) Key Source: Factory,External,Mixed
comment	Press Enter when selected to go into the associated Sub-Menu.

Field Name	Export Secure Boot variables
Help	Save NVRAM content of Secure Boot variable to a file

Field Name	Enroll Efi Image
Help	Allow Efi image to run in Secure Boot mode. Enroll SHA256 Hash certificate of a PE image into Authorized Signature Database (db)

4.4 Boot Page

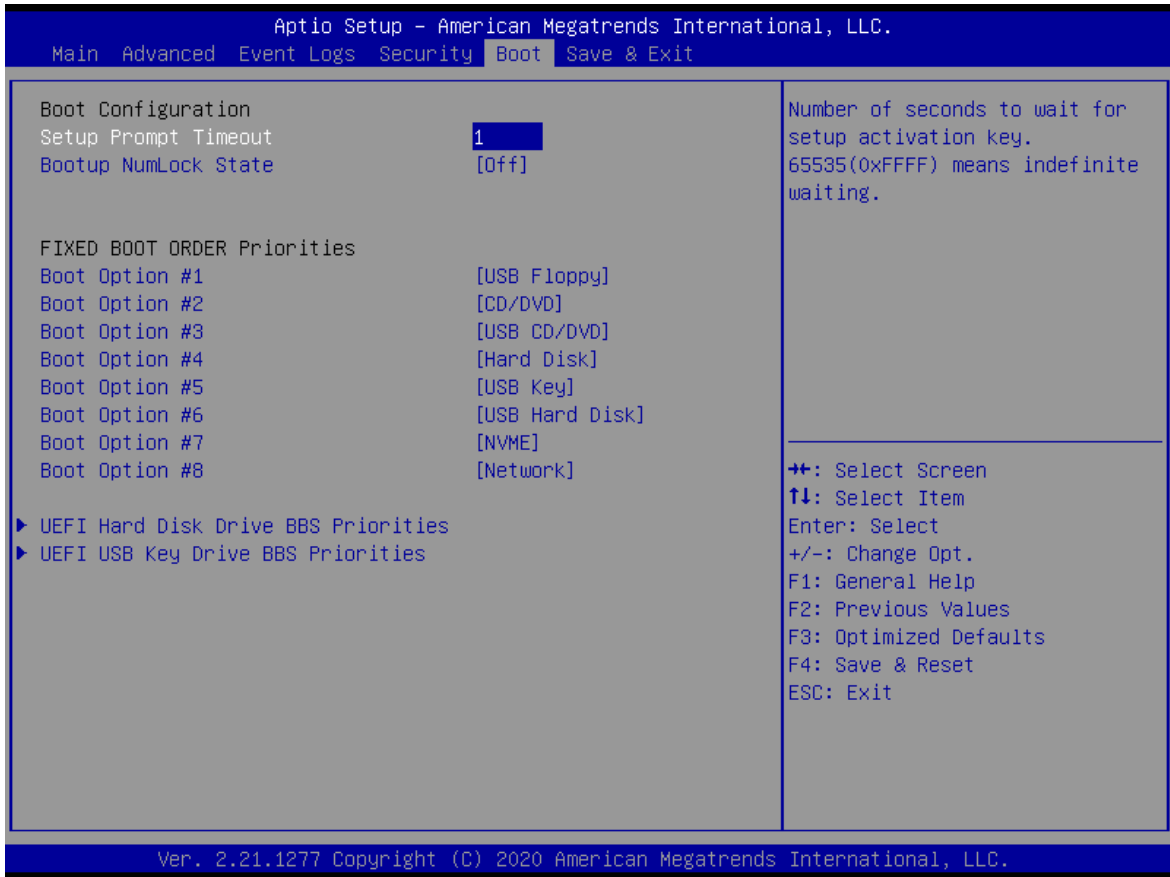

Field Name	Setup Prompt Timeout
Default Value	1
Possible Value	1~65535
Help	Number of seconds to wait for setup activation key. 65535(0xFFFF) means indefinite waiting.

Field Name	Bootup NumLock State
Default Value	[Off]
Possible Value	On Off
Help	Select the keyboard NumLock state

Field Name	Boot Option #1
Default Value	[USB Floppy]
Possible Value	USB Floppy, CD/DVD, USB CD/DVD, Hard Disk , USB Key, USB Hard Disk , NVME, Network, Disabled
Help	Sets the system boot order

Field Name	Boot Option #2
Default Value	[CD/DVD]
Possible Value	USB Floppy, CD/DVD, USB CD/DVD, Hard Disk , USB Key, USB Hard Disk , NVME, Network, Disabled
Help	Sets the system boot order

Field Name	Boot Option #3
Default Value	[USB CD/DVD]
Possible Value	USB Floppy, CD/DVD, USB CD/DVD, Hard Disk , USB Key, USB Hard Disk , NVME, Network, Disabled
Help	Sets the system boot order

Field Name	Boot Option #4
Default Value	[Hard Disk]
Possible Value	USB Floppy, CD/DVD, USB CD/DVD, Hard Disk , USB Key, USB Hard Disk , NVME, Network, Disabled
Help	Sets the system boot order

Field Name	Boot Option #5
Default Value	[USB Key]
Possible Value	USB Floppy, CD/DVD, USB CD/DVD, Hard Disk , USB Key, USB Hard Disk , NVME, Network, Disabled
Help	Sets the system boot order

Field Name	Boot Option #6
Default Value	[USB Hard Disk]
Possible Value	USB Floppy, CD/DVD, USB CD/DVD, Hard Disk , USB Key, USB Hard Disk , NVME, Network, Disabled
Help	Sets the system boot order

Field Name	Boot Option #7
Default Value	[NVME]
Possible Value	USB Floppy, CD/DVD, USB CD/DVD, Hard Disk , USB Key, USB Hard Disk , NVME, Network, Disabled
Help	Sets the system boot order

Field Name	Boot Option #8
Default Value	[Network]
Possible Value	USB Floppy, CD/DVD, USB CD/DVD, Hard Disk , USB Key, USB Hard Disk , NVME, Network, Disabled
Help	Sets the system boot order

Field Name	(UEFI) USB Floppy Drive BBS Priorities
Help	Specifies the Boot Device Priority sequence from available UEFI USB Floppy Drives.
Comment	Press Enter when selected to go into the associated Sub-Menu.

Field Name	(UEFI) CDROM/DVD Drive BBS Priorities
Help	Specifies the Boot Device Priority sequence from available CDROM/DVD Drives.
Comment	Press Enter when selected to go into the associated Sub-Menu.

Field Name	(UEFI) USB CDROM/DVD Drive BBS Priorities
Help	Specifies the Boot Device Priority sequence from available USB CDROM/DVD Drives.
Comment	Press Enter when selected to go into the associated Sub-Menu.

Field Name	(UEFI) Hard Disk Drive BBS Priorities
Help	Specifies the Boot Device Priority sequence from available UEFI Hard

	Disk Drives.
Comment	Press Enter when selected to go into the associated Sub-Menu.

Field Name	(UEFI) USB Key Drive BBS Priorities
Help	Specifies the Boot Device Priority sequence from available UEFI USB Key Drives.
Comment	Press Enter when selected to go into the associated Sub-Menu.

Field Name	(UEFI) USB Hard Disk Drive BBS Priorities
Help	Specifies the Boot Device Priority sequence from available UEFI USB Hard Disk Drives.
Comment	Press Enter when selected to go into the associated Sub-Menu.

Field Name	(UEFI) NVME Drive BBS Priorities
Help	Specifies the Boot Device Priority sequence from available UEFI NVME Drives.
Comment	Press Enter when selected to go into the associated Sub-Menu.

Field Name	(UEFI) NETWORK Drive BBS Priorities
Help	Specifies the Boot Device Priority sequence from available UEFI NETWORK Drives.
Comment	Press Enter when selected to go into the associated Sub-Menu.

4.4.1 (List Boot Device Type) Drive BBS Priorities

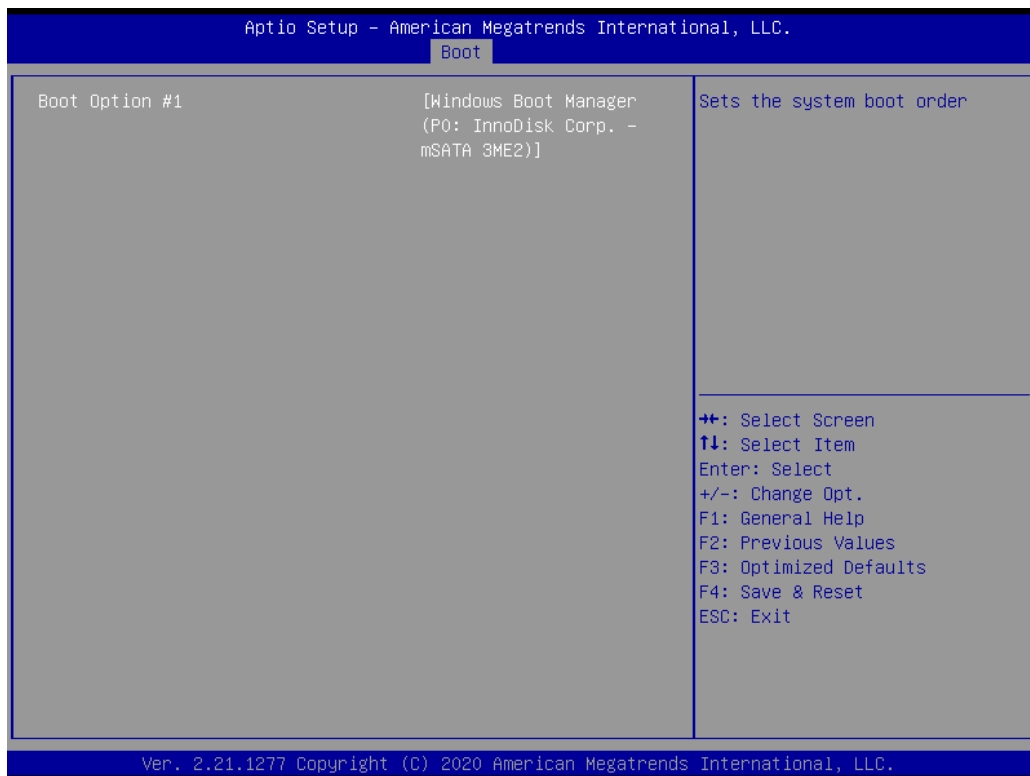

Field Name	Boot Option #1
Default Value	
Possible Value	Boot Device Name 1 of this type, Disable
Help	Sets the system boot order

4.5 Save & Exit Page

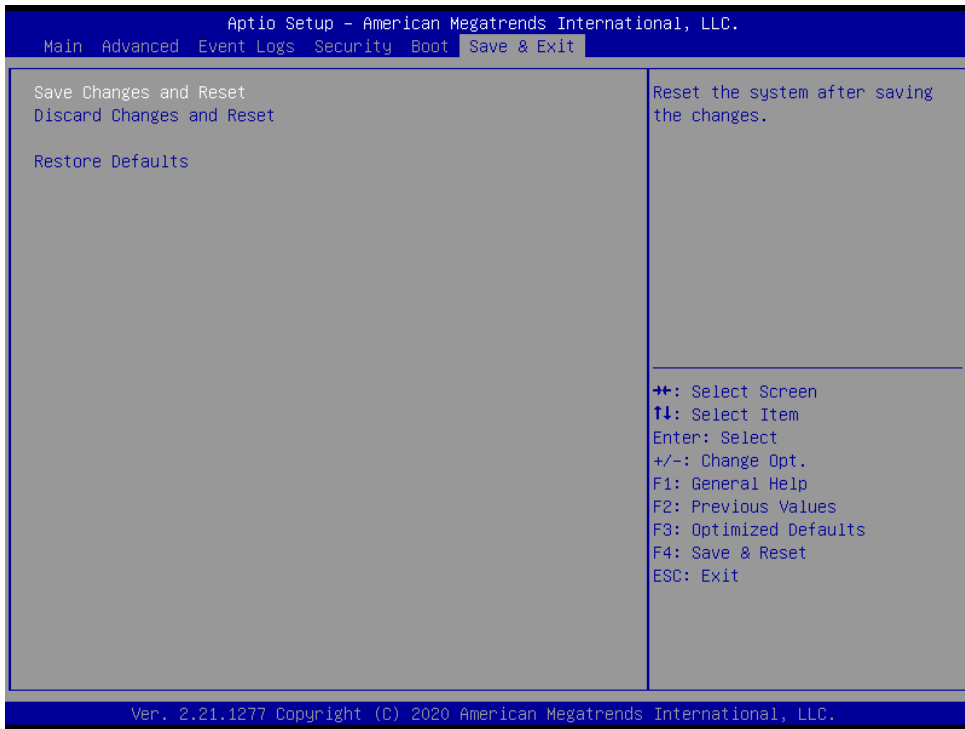

Field Name	Save Changes and Reset
Help	Reset the system after saving the changes.

Field Name	Discard Changes and Reset
Help	Reset system setup without saving any changes.

Field Name	Restore Defaults
Help	Restore/Load Default values for all the setup options.

4.6 Event Logs



Field Name	Change Smbios Event Log Settings
Help	Press <Enter> to change the Smbios Event Log configuration.
Comment	Press Enter when selected to go into the associated Sub-Menu.

Field Name	View Smbios Event Log
Help	Press <Enter> to view the Smbios Event Log records.
Comment	Press Enter when selected to go into the associated Sub-Menu.

4.6.1 Change Smbios Event Log Settings



Field Name	Smbios Event Log
Default Value	[Enabled]
Possible Value	Enabled Disabled
Help	Change this to enable or disable all features of Smbios Event Logging during boot.

Field Name	Erase Event Log
Default Value	[No]
Possible Value	No / Yes, Next reset / Yes, Every reset
Help	Choose options for erasing Smbios Event Log. Erasing is done prior to any logging activation during reset.

Field Name	When Log is Full
Default Value	[Do Nothing]
Possible Value	Do Nothing Erase Immediately
Help	Choose options for reactions to a full Smbios Event Log.

4.6.2 View Smbios Event Log

Aptio Setup - AMI

Event Logs

DATE	TIME	ERROR CODE	SEVERITY	COUNT	DESCRIPTION
06/04/20	06:35:10	Smbios 0x16	N/A	N/A	Log Area Reset and Count is applicable only for Multi-Events

++: Select Screen
 ↑↓: Select Item
 Enter: Select
 +/-: Change Opt.
 F1: General Help
 F2: Previous Values
 F3: Optimized Defaults
 F4: Save & Reset
 ESC: Exit

Version 2.21.1278 Copyright (C) 2020 AMI

Field Name	DATE / TIME / ERROR CODE / SEVERITY / COUNT
Default Value	MM/DD/YY HH:MM:SS Smbios 0x16 N/A N/A
Possible Value	By Events.
Help	By Events.