

# XM1

AI Inference/ Machine Learning/ Deep Learning  
**Rugged GPU Computing System**  
 Supports Intel® Raptor Lake-S / Alder Lake-S Core-i processors

## Introduction

- Supports Intel® Raptor Lake-S 13th/Alder Lake-S 12th Gen Core-i Processors
- Support 2 x DDR5 SO-DIMM (Up to 64GB)
- HDMI, DisplayPort, VGA, Dual 2.5G LAN
- Support 10 x USB, 4 x RS232, and 32-bit DIO
- 9~48V Wide Power Range

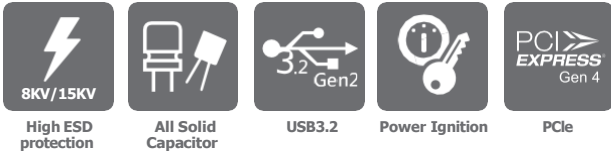

## I/O Interface

Front I/O

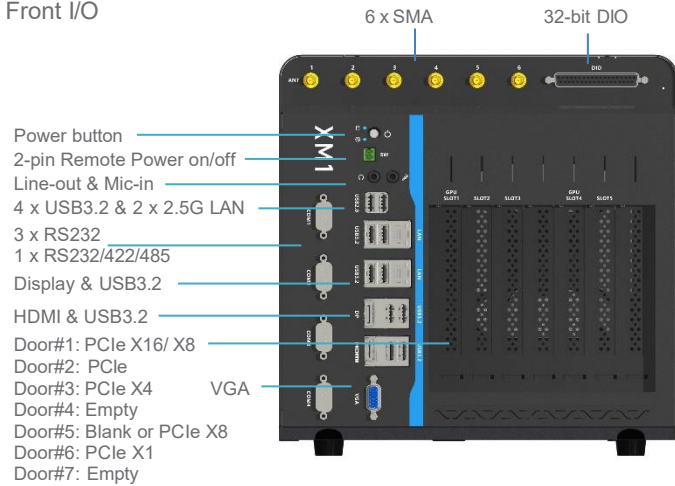

Rear I/O

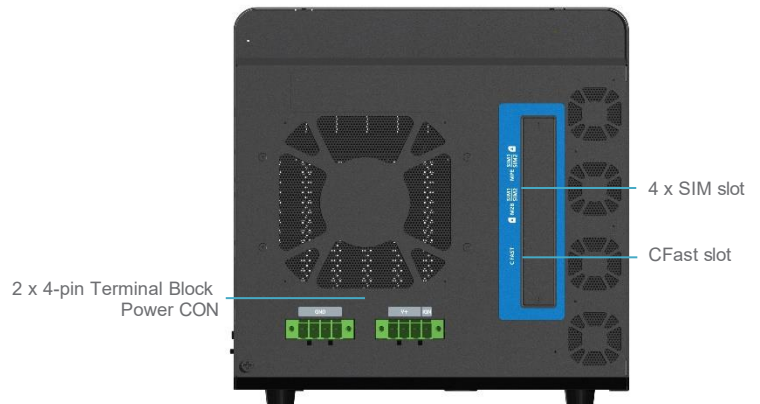

Side I/O & Dimensions (mm)

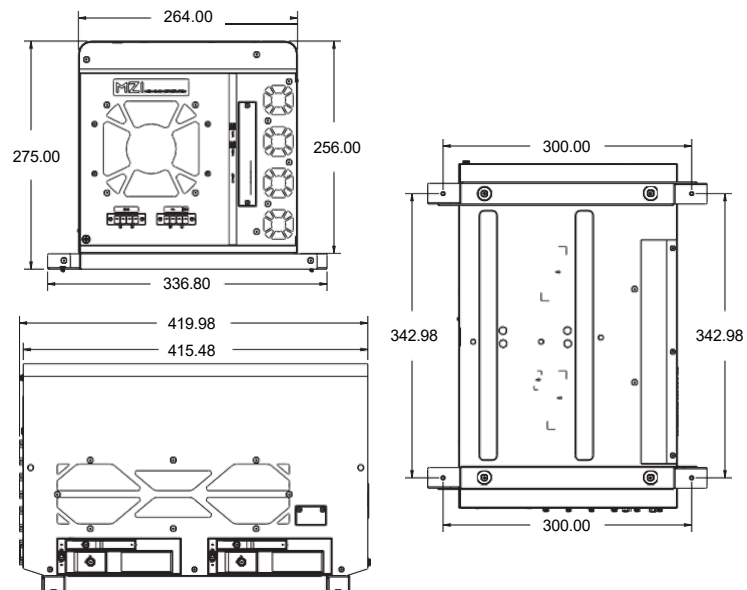
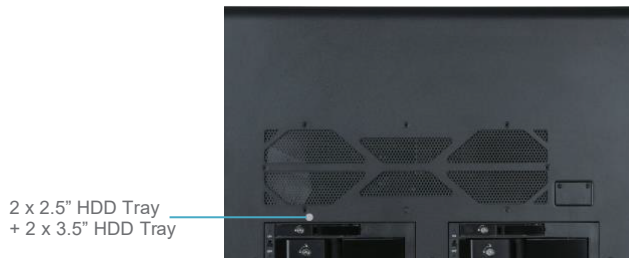

## XM1 Embedded System

SYSTEM	
<b>CPU</b>	14th/13th/12th Gen Intel® Raptor Lake-S Refresh/Raptor Lake-S/Alder Lake-S Core i9/i7/i5/i3/Celeron/Pentium (Up to 125W)
<b>Chipset</b>	Intel® R680E
<b>System Memory</b>	2 x 262-pin SO-DIMM / DDR5 4800 MHz / Max. 64 GB (Non-ECC/ECC)
<b>Graphics</b>	Intel® UHD Graphics
<b>Display Interface</b>	VGA / HDMI 2.0b / DisplayPort 1.4
<b>Storage Slot</b>	1 x M.2 B Key 2280/2260/2242 Slot / 2 x Hot Swappable 2.5" HDD Tray (support 7-9.5mm height) / 2 x Hot Swappable 3.5" HDD Tray / 1 x CFAST slot / 1 x M.2 M Key 2280/2262/2242 SSD slot / 1 x mSATA *4 x SATA, 2 x M.2 SATA, and 1 x mSATA, all these 7 SATA ports can be configured in SATA RAID 0/1/5/10.
<b>Ethernet</b>	1 x Intel® I225-LM 2.5GbE LAN + 1 x Intel® I225-V 2.5GbE LAN
<b>Audio</b>	Realtek® ALC888S
<b>I/O Chipset</b>	Nuvoton NCT6126D
<b>TPM</b>	Nuvoton NPCT750AAAYX TPM2.0
<b>Expansion Slot</b>	1 x M.2 3052 / 3042 / 2242 / 2260 / 2280 B key (USB3.0 , SATAIII, PCIeX1) w/ SIM slot 1 x M.2 2230/ 2242 / 2260 / 2280 M key (PCIeX4 NVME, SATAIII) 1 x M.2 2230 E key (CNVi , PCIeX1, USB 2.0) 1 x Mini PCIe Full size (USB2.0 / SATAIII / PCIeX1) 1 x Mini PCIe Full size (USB2.0 / PCIeX1) #1: 1 x PCIe X16 (Gen4) or PCIe X8 (Gen4) #2: 1 x PCIe X4 in PCIe X16 physical connector (Gen4) #3: 1 x PCIe X4 in PCIe X16 physical connector (Gen4) #4: 1 x PCIe X8 in PCIe X16 physical connector (Gen4 x8 = Gen3 x16 Bandwidth) #5: 1 x PCIe X1 in open ended connector (Gen3)
<b>Internal Speaker</b>	1 x Buzzer
<b>Indicator</b>	Power Button / Power LED / HDD LED
<b>Internal I/O</b>	1 x USB3.2 Gen1 TYPE A / 1 x USB2.0 TYPE A
<b>Front I/O</b>	1 x 2-pin Terminal Block Remote Power on / off / 3 x RS232 / 4 x USB3.2 Gen2 / 4 x USB3.2 Gen1 / 6 x SMA hole with rubber cap / 1 x DB37 connector for 32 bit DIO / 1 x DisplayPort 1.4 / 1 x VGA / 1 x HDMI 2.0b / 2 x USB 2.0 1 x RS232 / 422 / 485 1 x Mic-in 1 x Line-out
<b>Rear I/O</b>	2 x 4-pin Terminal Block Power Input 2 x SIM slot to M.2 B Key slot 2 x SIM slot to mPCIe slot 1 x CFAST slot
POWER REQUIREMENT	
<b>Power Input</b>	9~48V Wide Range DC Input w/ Terminal Block Connectivity
MECHANICAL	
<b>Thermal Design</b>	Fan
<b>Mounting</b>	Wall mount
<b>Dimensions</b>	264mm(w) x 415mm(d) x 256mm(w)
<b>Material</b>	Top cover: Aluminum Alloy, Bezel and chassis: Steel
ENVIRONMENTAL	
<b>Operating Temperature</b>	-40°C ~ 70°C (w/ 35W CPU, w/o GPU card) -40°C ~ 60°C (w/ 65W CPU, w/o GPU card) -40°C ~ 40°C (w/ 125W CPU, w/o GPU card) *Max OT limit -10°C w/ dual GPU card / with 0.7m/s Air Flow and Wide Temperature Memory/Storage *Please consult with your sales contact window about the Operating Temperature of GPU Card Configurations
<b>Storage Temperature</b>	-40 ~ 85°C (-40 ~ 185°F)
<b>Storage Humidity</b>	10% ~ 95% @85°C non-condensing
<b>Humidity</b>	10% ~ 90% R/H (Non-condensing)
<b>Vibration Resistance</b>	MIL-STD-810H, Follow Method 514.8C-I Category 4 for Truck
<b>Shock Resistance</b>	MIL-STD-810H 516.8 procedure I - functional shock, Operating 20G, 11ms (Follow IEC 60068-2-27 half sine)
<b>Certification</b>	CE / FCC Class A
OS	
<b>OS Support</b>	Windows® 10 IoT LTSC 64bit (LTSC 2021) / Ubuntu 22.04 / Windows® 11 64bit

\*with 0.7m/s Air Flow and Wide Temperature Memory/Storage