

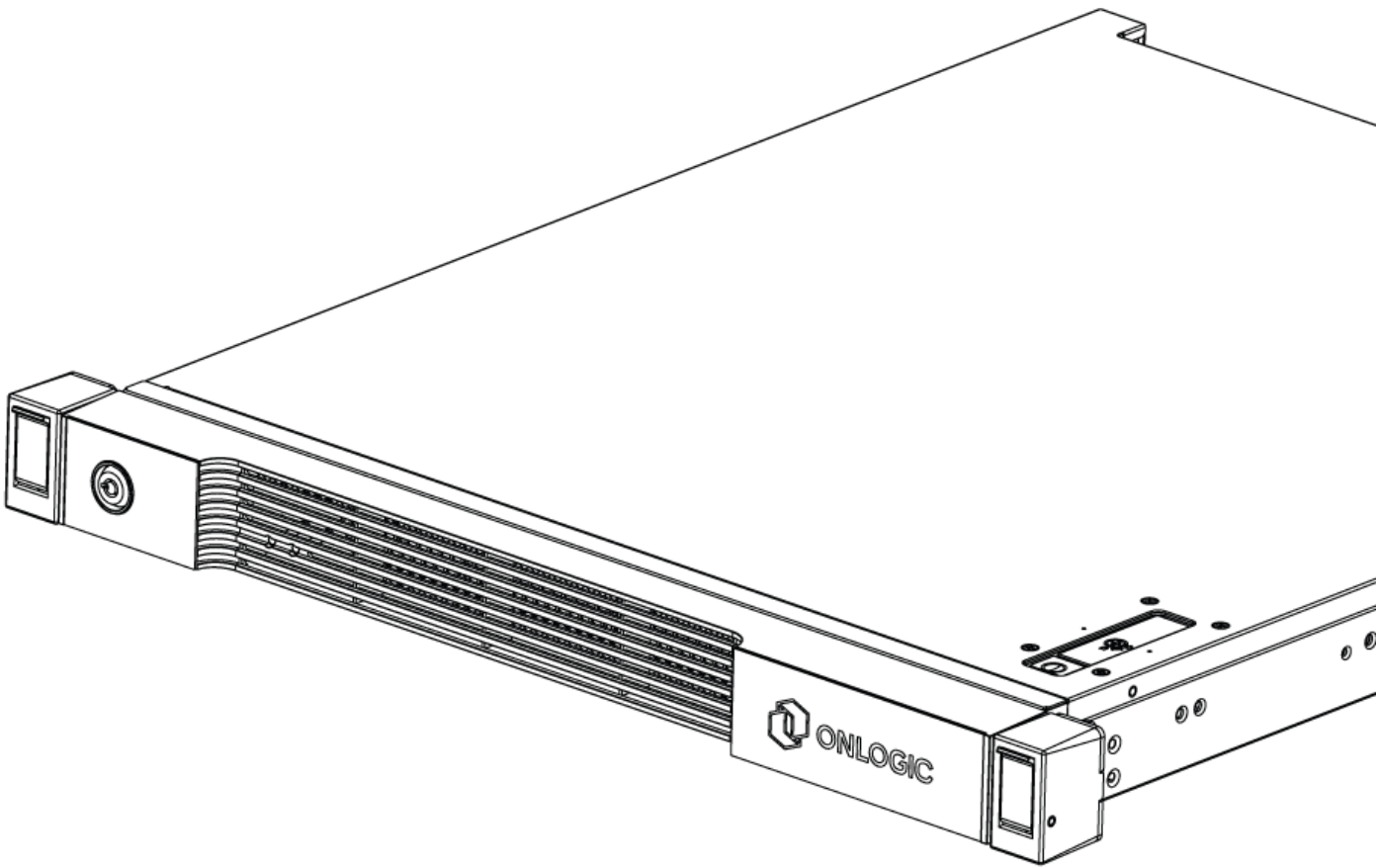

Axial AC101 Product Manual



Revision History

Date	Revision History
5/24/2023	First release of Axial AC101 manual

Table of Contents

1 - System Overview	4
1.1 - Accessories	5
1.2 - Latest Drivers, Firmware, and Additional Information	5
1.3 - Product Specifications	6
1.4 - System Dimensions and Exterior Features	8
1.4.1 - System Dimensions	8
1.4.2 - Front I/O Ports	9
1.4.3 - Rear I/O Ports	9
1.4.4 - Front LEDs & Buttons	10
1.4.5 - Security Bezel	11
1.4.6 - Two Point Locking Lid with Intrusion Detection	11
1.5 - System Label	13
1.6 - Front Service Label	13
1.7 - Motherboard Overview	13
1.7.1 - System Block Diagram	14
1.7.2 - Internal Motherboard Features & Headers	15
2 - I/O Definitions	17
2.1 - Networking	17
2.2 - 1GbE Dedicated BMC Port LEDs	18
2.3 - 1GbE Networking Port LEDs	18
2.4 - 10GbE Networking Port LEDs	19
2.5 - USB Ports	19
2.6 - DisplayPort Video	19
2.7 - HDMI Video	19
2.8 - VGA Video	19
3 - Primary Component Connectors	20
3.1 - M.2 2280/2260/2242/2230 M-key 1	20
3.2 - TPM Header	20
3.3 - SATA Headers	21
3.4 - OCuLink Headers	21
3.5 - PCIe Gen 4.0 x16 Slot	21
3.6 - DDR5 UDIMM Slots	21
3.6.1 - Supported Memory Modes	21
3.6.1.1 - Single-Channel Mode	21
3.6.1.2 - Dual-Channel Mode – Intel® Flex Memory Technology Mode	21
3.6.1.3 - Dual-Channel Symmetric Mode (Interleaved Mode)	22
3.6.2 - DIMM Population Requirements	23
4 - Thermals and Cooling	24
4.1 - System Fans and Airflow Direction	24
4.2 - Temperature Sensors	25
4.3 - Default Fan Settings	26
4.3.1 - Fan Zone Assignments	26
4.3.1.1 - Fan Zone 1 - CPU Area	26
4.3.1.2 - Fan Zone 2 - PCIe / GPU Area	27

4.3.2 - Additional Fan Defaults	28
4.4 - Thermal Performance and Validation	28
4.4.1 - Test Conditions	28
4.4.2 - Test Results	30
5 - Power	31
5.1 - Supported Power Supplies	31
5.2 - Power Redundancy	31
5.3 - Wake-Up Events	32
6 - Operating Systems	33
6.1 - Windows 10 IoT Enterprise 2021 LTSC Licensing	33
7 - Mounting Hardware	34
7.1 - Rack Mounting	34
7.1.1 - Rackmount 23" Ball Bearing Slide Rails	34
7.1.2 - Rackmount 23" Ball Bearing Cable Management Arm Slide Rail Kit	35
7.1.3 - Rackmount 28" Simple Locking Ball Bearing Slide Rails	36
7.2 - Wall Mounting	37
7.2.1 - Wall mount kit	37
8 - Regulatory Compliance	38
8.1 - CE	38
8.2 - FCC Statement	38
8.3 - ISED	38
8.4 - UKCA	38
9 - Appendices	39
9.1 - Appendix A: Technical Support	39
9.2 - Appendix E: Compliance Information	39
9.2.1 - Safe use and installation instructions	39
9.2.2 - Précautions et guide d'installation	40

1 - System Overview

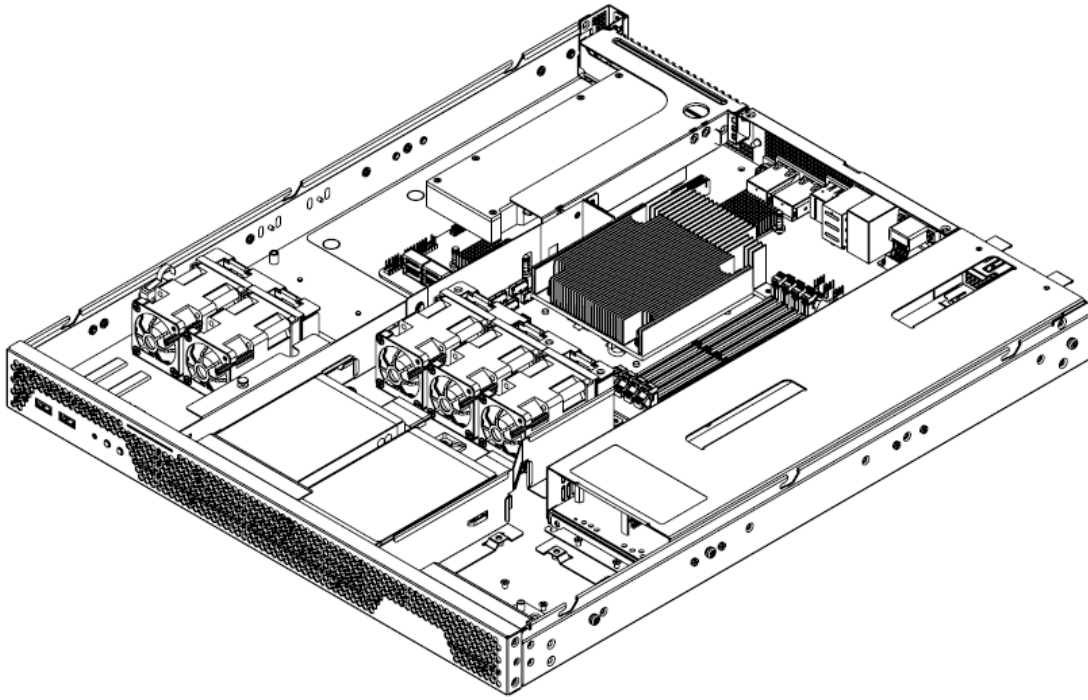

Axial AC101 without Security Bezel

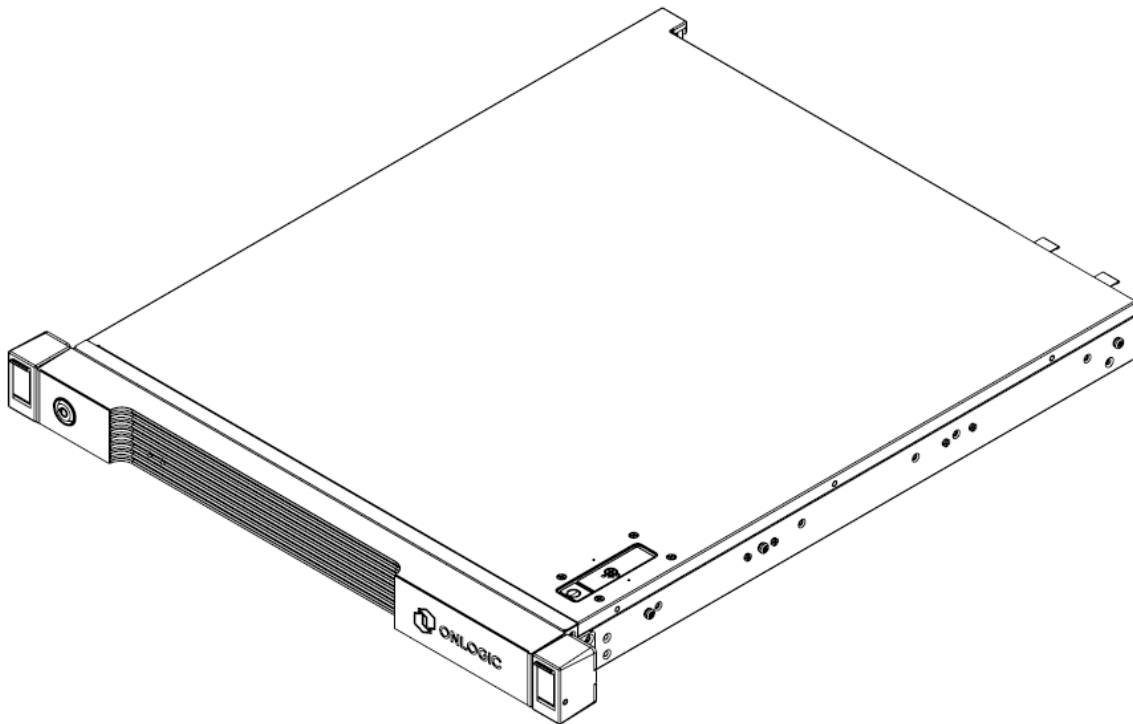

Axial AC101 with Security Bezel

1.1 - Accessories

The following accessories are included with every system:

- PSU filler (2RALXX5862A1)
- Nvidia 9.5" GPU mounting kit w/ screws (2RALXX5861A1)
- SSD cable brackets (2RALXX5859A1)
- Spare motherboard standoffs (2RALXX282300)
- Spare PCIe riser screws (2RALXX585800)
- Cable management ties
- Security bezel key

If additional items were purchased, such as rail mounting kits/brackets, they will be boxed separately.

1.2 - Latest Drivers, Firmware, and Additional Information





Drivers, firmware, and product information can be found on the Axial 101 product page.

US: <https://www.onlogic.com/ac101/>

EU: <https://www.onlogic.com/eu-en/ac101/>

1.3 - Product Specifications

OnLogic Axial 100 Series	
Variants	AC101 - High-Performance 1U with 150W PCIe 4.0 x16 Expansion
Processor	Intel® 13th Gen Alder Lake-S (LGA1700) Core i3, i5, i7 & i9 up to 24-core 32-thread i3-13100E or TE, i5-13500E or TE, i7-13700E or TE, i9-13900E or TE 125W PL2 (Power Level 2)
Memory	Support up to 4x DDR5-4800 UDIMMs (non-ECC or ECC) Up to 128GB total memory Maximum operational speed: 4400 MT/s
Chipset	Intel W680
Integrated Graphics	Intel UHD Graphics 730 (i3) or 770 (i5, i7, i9)
Front I/O	2x USB 3.2 Gen 1 Type A 1x Power Button / LED (White) 1x ID button / LED (Blue)
Rear I/O	1x 1GbE Dedicated Management (BMC/IPMI) 2x 1GbE LAN Intel i210 2x 10GbE LAN Intel X710 2x USB 3.2 Gen 1 Type-A 1x DisplayPort 1x HDMI 1x VGA 1x DB9 (COM) 1x ID button / LED (Blue)
Expansion & Storage	1x M.2 2280/2260/2242/2230 M-key (PCIe Gen 3 x4) 1x PCIe Gen 4 x16 Full Height, Full Length slot (up to 150W) Up to 4x 2.5" Drives (NVMe or SATA)
Special Features	ASPEED AST2600: Full Web UI, iKVM, vMedia support 1/10 Network Controller Sideband Interface (NC-SI) Optional TPM 2.0 module (Infineon SLB9670) or Intel PTT (Native) Chassis Intrusion Detection Security Bezel Secure Boot
Operating Systems	Microsoft Windows 10 IoT Enterprise 2021 LTSC (Value/High End) 64-bit Microsoft Windows 11 Professional 64-bit
LAN Controllers	2x Intel i210 Controllers (2x 1GbE ports) 1x Intel X710 Controller (2 x 10GbE ports)
Power Supplies	Up to 2 PSUs with PMBUS monitoring, 100~240 VAC input 450W Gold 750W Platinum
Dimensions (W x H x D)	430 x 43.5 x 515mm (16.9 x 1.7 x 19.7") without Security Bezel 483 x 43.5 x 534mm (19.0 x 1.7 x 21.0") with Security Bezel
Weight	System Maximum: 10.02 kg (22.1 lbs) Shipping Maximum: 12.88 kg (28.4 lbs)

Mounting	Rack Mount 28" Toolless Slide Rail Rack Mount 23" Slide Rail Rack Mount 23" Slide Rail with Cable Management Arm Wall Mount
Operating Temperature	5°C ~ 40°C (ASHRAE A3 Operating Temperature) Maximum ambient temperature decreases by 1°C for every 175m (574 ft) increase in altitude above 900m (2,953 ft)
Storage Temperature	-40°C ~ 70°C
Operating Humidity	8~85% Relative, non-condensing Maximum dew point 24°C
Storage Humidity	0~95% Relative, non-condensing Maximum dew point 24°C
Shock & Vibration	ISTA 6-FEDEX-A
Certifications	 FCC 47 CFR Part 15 Subpart B (Class A) CAN ICES-003(A) / NMB-003(A) (Class A) (Class B upon request)  EN 63268-1 CISPR 32/EN 55032 (Class A; Class B upon request) CISPR 35/EN 55035 Radio Equipment Directive (2014/53/EU) RoHS RoHS 3 (2015/863/EU)  WEEE Directive (2012/19/EU)  IEC/EN/UL 62368-1 (UL File No. E490677) LISTED
Countries of Use	Available countries: Americas: Canada, United States Europe: Austria, Belgium, Bulgaria, Croatia, Czech Republic, Cyprus, Denmark, Estonia, Finland, France, Germany, Greece, Hungary, Iceland, Ireland, Italy, Latvia, Lithuania, Liechtenstein, Luxembourg, Malta, Norway, The Netherlands, United Kingdom, Poland, Portugal, Romania, Slovakia, Slovenia, Spain, Sweden Available countries upon request: Asia: Australia, China, Japan, New Zealand Other countries may be available, please call

1.4 - System Dimensions and Exterior Features

1.4.1 - System Dimensions

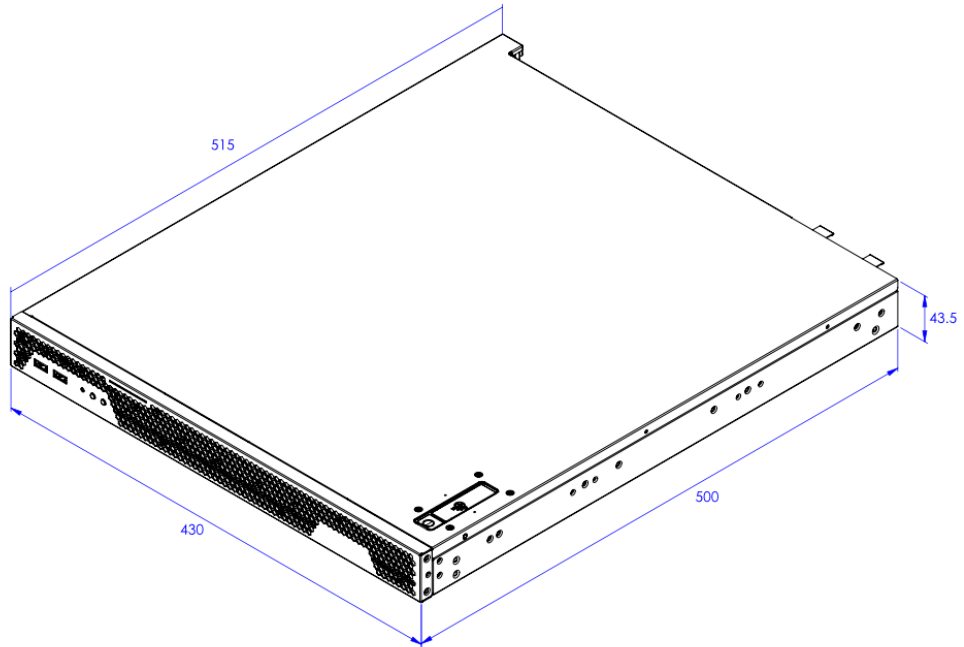

Axial AC101 without Security Bezel

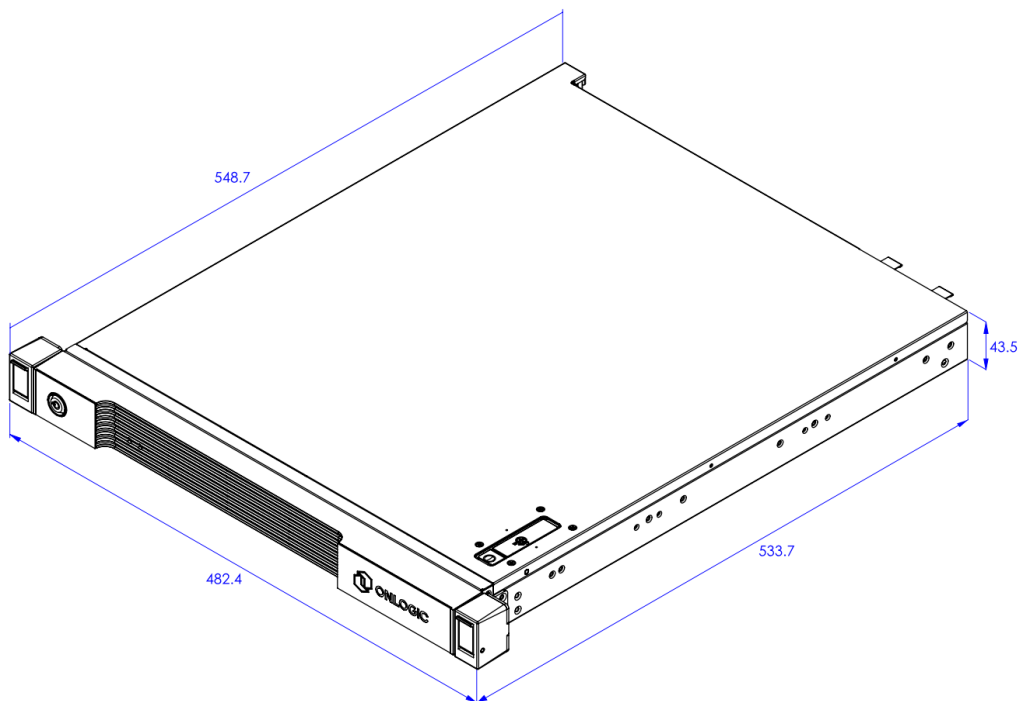

Axial AC101 with Security Bezel

1.4.2 - Front I/O Ports

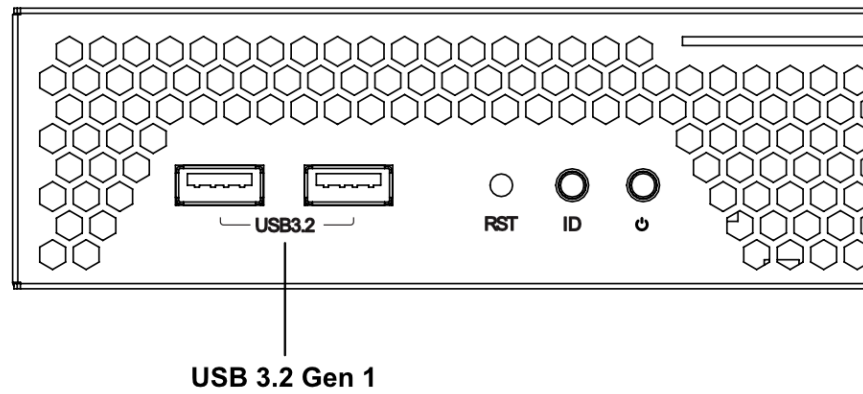

1.4.3 - Rear I/O Ports

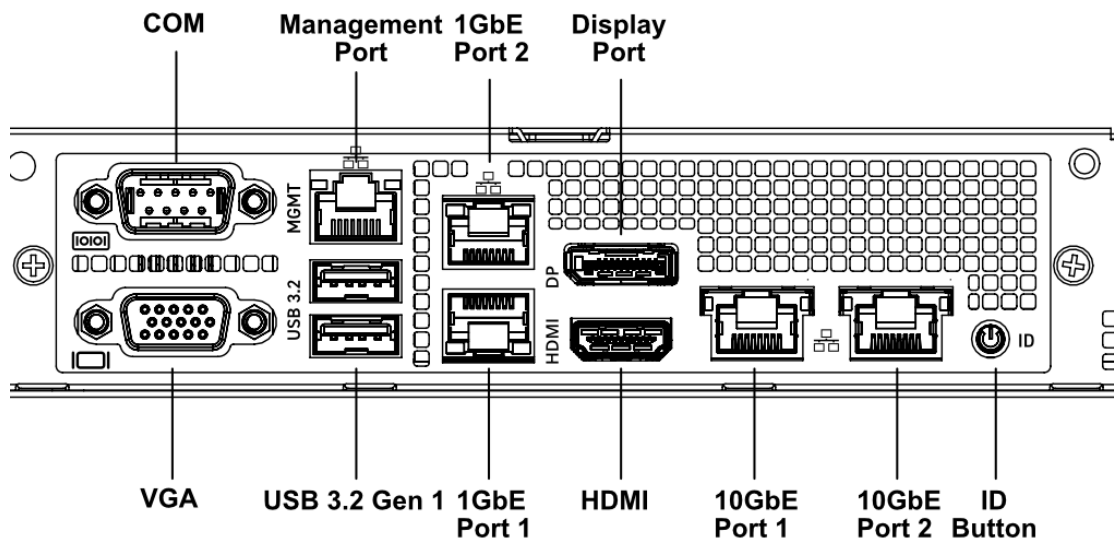

1.4.4 - Front LEDs & Buttons

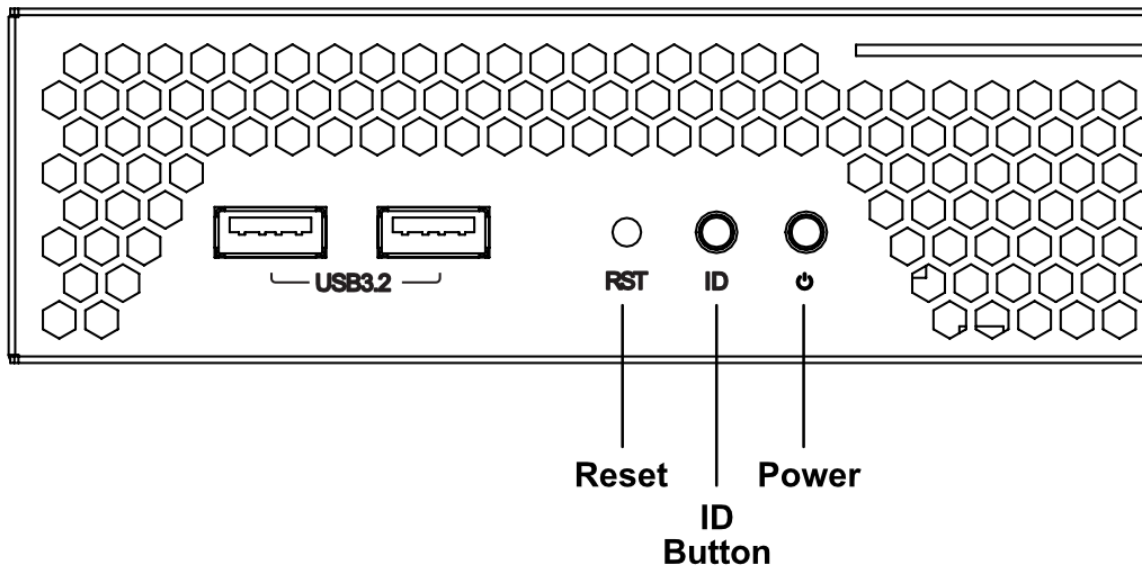

LED / Button	Color	On	Off	Blink
Power	White	Device is on	Device is off	-
ID (Identification)	Blue	ID indicator asserted	ID indicator is deasserted	ID indicator is blinking
RST (Reset)	-	-	-	-

The ID LED/Button is available to assist with locating the system. ID may be physically turned On / Off by physically pressing the ID button. ID may also be turned On, Off, or set to Blink from the Baseboard Management Controller (BMC) Web UI.

RST Button will reset the system.

1.4.5 - Security Bezel

The Axial AC101 Edge Server comes with a security bezel. The security bezel helps prevent unauthorized access and tampering with the front ports and buttons of the system.

A barrel lock is used to secure the security bezel in place. A key for the barrel lock is included in the accessory package.

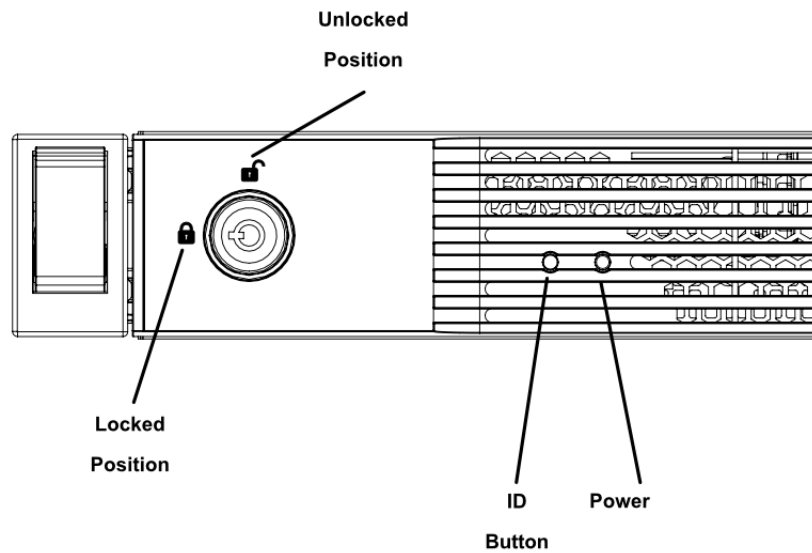

1.4.6 - Two Point Locking Lid with Intrusion Detection

The Axial AC101 Edge Server chassis lid has a two point locking locking mechanism with an intrusion mechanism built natively into the system chassis.

For the two point locking mechanisms, the first locking point is the top latch with a tamper resistant screw lock.

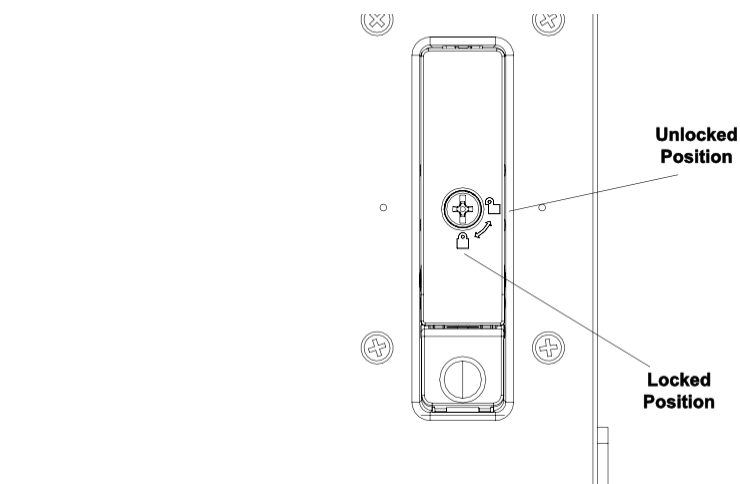

The second lid locking point is a thumb screw located in the rear of the system.

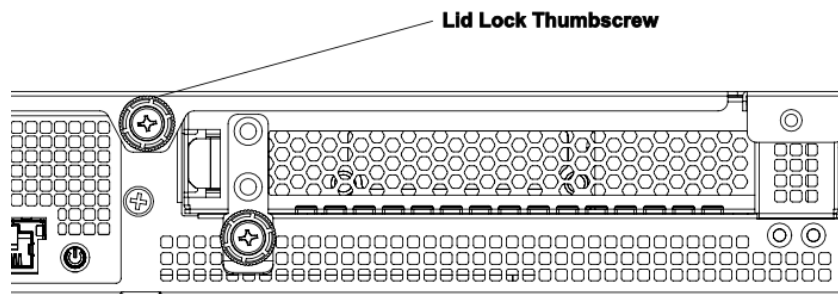

In the event that the system lid is removed while power is present to the system, the intrusion switch will detect this event and the Chassis Intrusion sensor will be asserted. Relative to the intrusion, this event will also be logged in the Baseboard Management Controller event log.

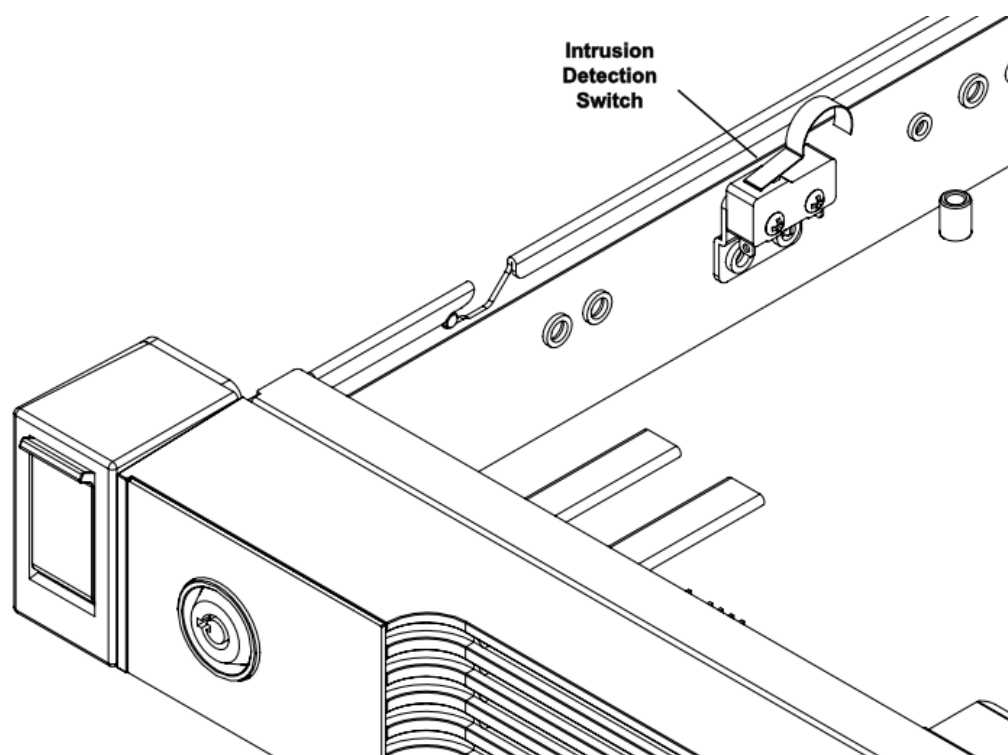

1.5 - System Label

The system label is located on the bottom of the chassis as depicted in the image below. The system label will contain the following information:

- System Model
- OnLogic Serial Number
- Regulatory & Compliance Certification Logos

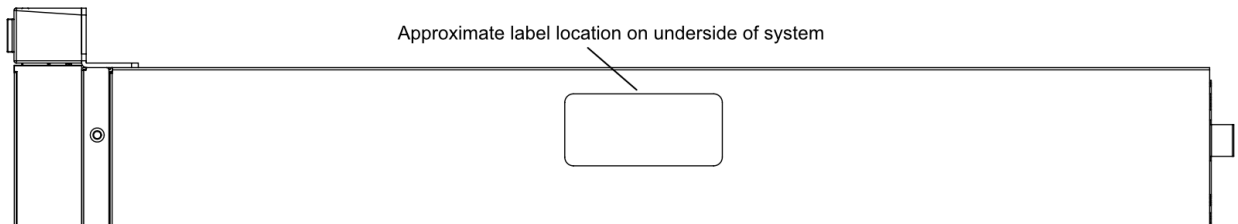

1.6 - Front Service Label

On the front of the chassis, there is a retractable product information label containing pertinent product information such as:

- System Model
- OnLogic Serial Number
- BMC MAC addresses

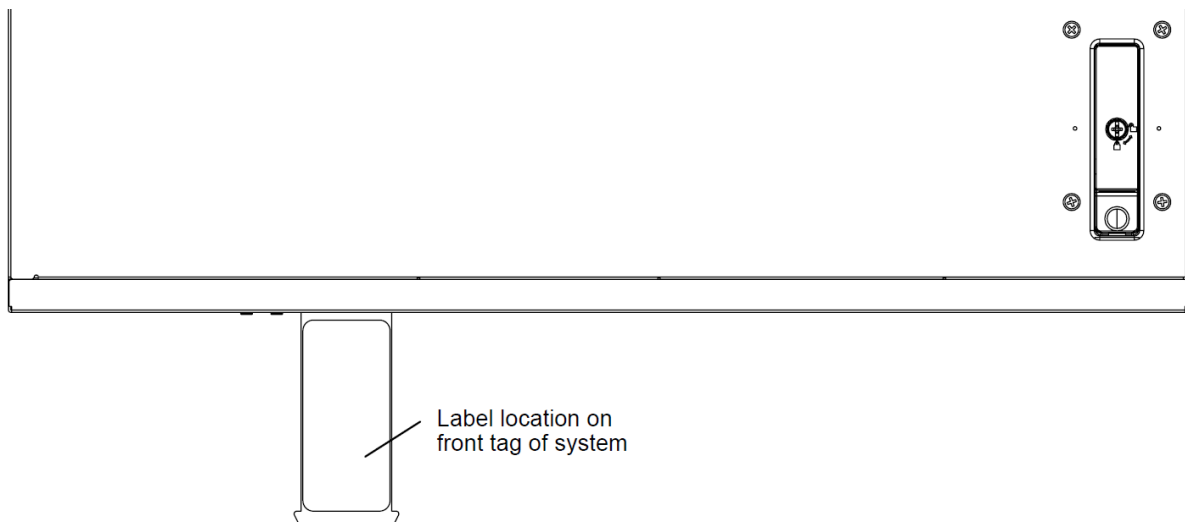

1.7 - Motherboard Overview

1.7.1 - System Block Diagram

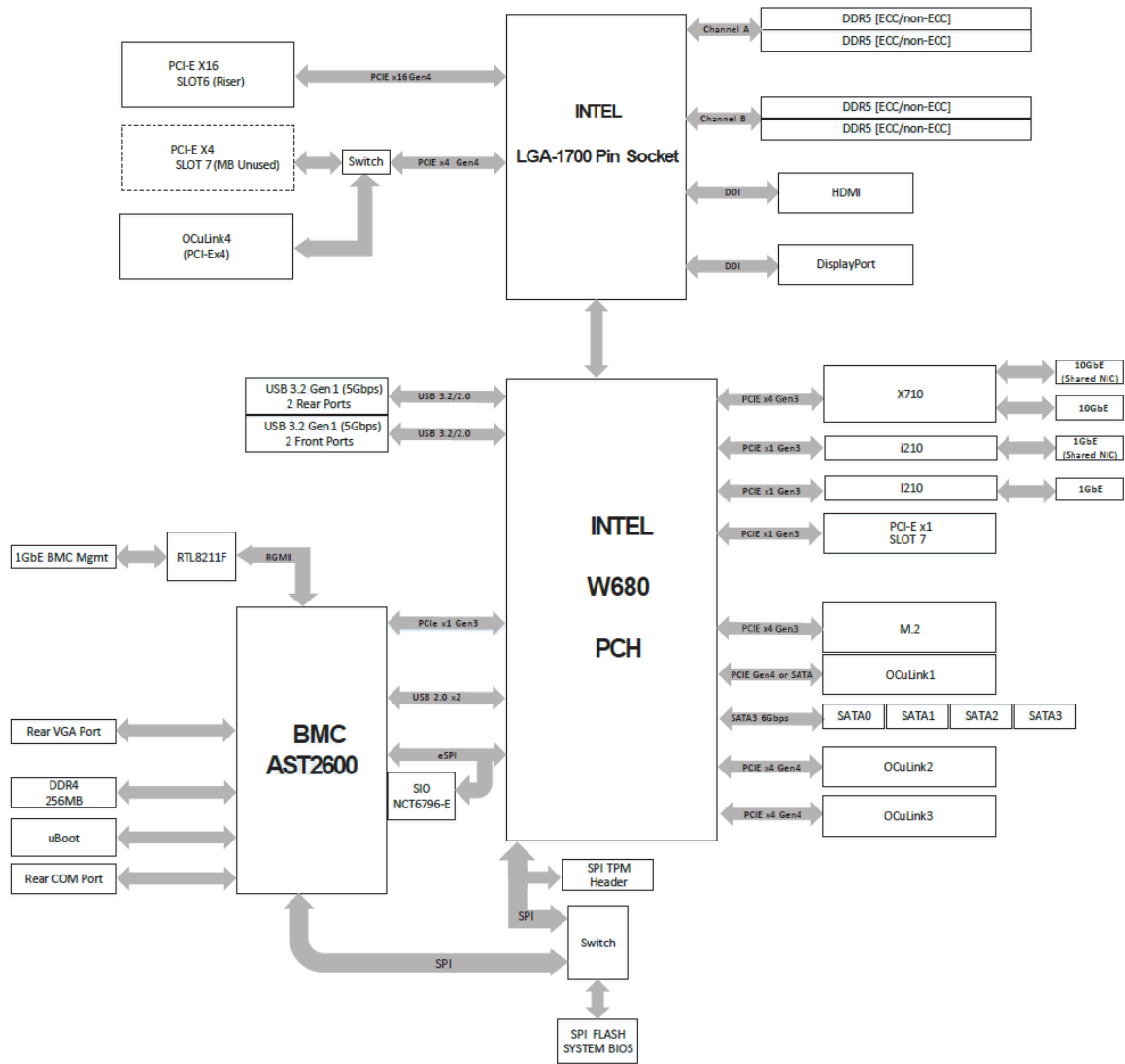

1.7.2 - Internal Motherboard Features & Headers

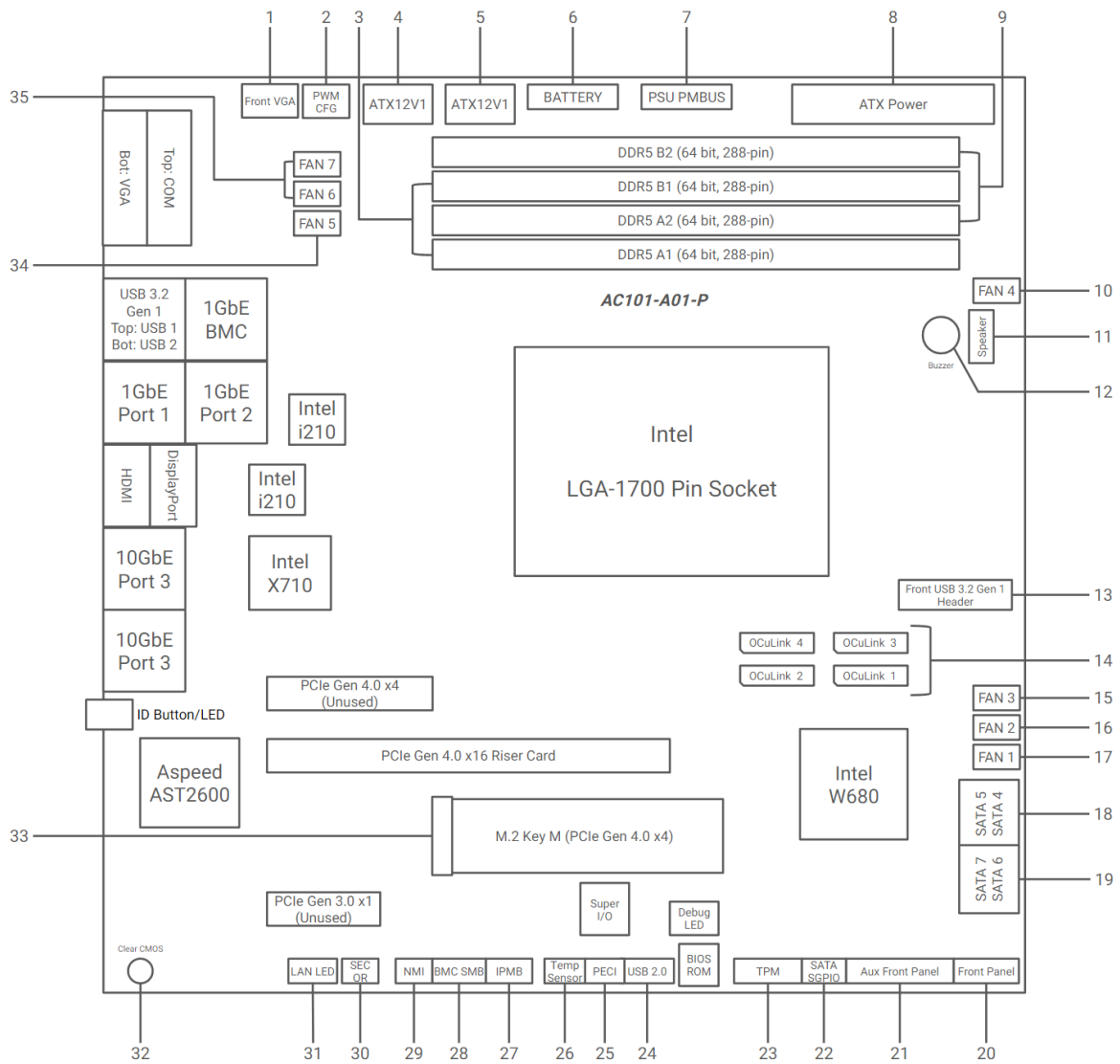

Item	Description	Item	Description
1	Front VGA Header, (FRNT_VGA1), Unused	19	2x SATA Header (SATA3_7)(Upper), (SATA3_6)Lower
2	PWM Configuration Header (PWM_CFG1), Unused	20	System Front Panel Header (PANEL1)
3	2x DDR5 DIMM Slots (DDR5_A1, DDR5_B1)	21	Auxiliary Front Panel Header (AUX_PANEL1)
4	ATX 12V Power Connector (ATX12V1)	22	SATA SGPIO Connector (SATA_SGPIO1), Unused
5	ATX 12V Power Connector (ATX12V2)	23	SPI TPM Header (TPM_BIOS_PH1)
6	CMOS CR2032 Battery	24	USB 2.0 Header (USB_1_2), Unused
7	PSU SMBus Header (PSU_SMB1)	25	CPU PECU Mode Jumper (PECI1)
8	ATX Power Connector (ATXPWR1)	26	Ambient Temperature Sensor Header (TR1)
9	2x DDR5 DIMM Slots (DDR5_A2, DDR5_B2)	27	Intelligent Platform Management Bus Header (IPMB_1)
10	Chassis Fan Header (FAN4)	28	BMC SMBus Header (BMC_SMB_1)
11	Chassis Speaker Header (SPEAKER1), Unused	29	Non Maskable Interrupt Button (NMI_BTN1)
12	Buzzer (Audible boot error indicator)	30	Security Override Jumper (SEC_OR1)
13	Front USB 3.2 Gen 1 Header	31	LAN LED
14	4x OcuLink PCIe 3.0 x4 for NVMe drives	32	Clear CMOS Pad (CLRMOS1)
15	Chassis Fan Header (FAN3)	33	M.2 Socket (M.2) (Type 2230/2242/2260/2280)
16	Chassis Fan Header (FAN2)	34	Chassis Fan Header (FAN5)
17	Chassis Fan Header (FAN1)	35	2x Chassis Fan Header (FAN6, FAN7), Unused
18	2x SATA Header (SATA3_5)(Upper), (SATA3_4)Lower		

2 - I/O Definitions

2.1 - Networking

The Axial AC101 features the following onboard Ethernet ports:

Port	Chipset	Capabilities
1GbE Mgmt	Realtek RTL8211F (Attached to ASPEED AST2600)	Dedicated BMC Management port. Port is only used for system management functions such as IPMI, RedFish, Remote Management, etc. This port is not usable as an Ethernet port by the operating system.
1GbE Port 1	Intel I210	1GbE Port This port may be configured to operate in a Shared NIC mode, enabling access to the BMC network connection and supporting the system management functions such as IPMI, RedFish, Remote Management, etc.
1GbE Port 2	Intel I210	1GbE Port
10GbE Port 3	Intel X710	10GbE Port This port may be configured to operate in a Shared NIC mode, enabling access to the BMC network connection and supporting the system management functions such as IPMI, RedFish, Remote Management, etc.
10GbE Port 4		10GbE Port

2.2 - 1GbE Dedicated BMC Port LEDs

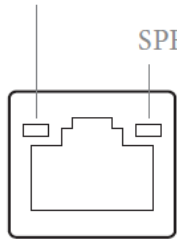
 ACT/LINK LED SPEED LED LAN Port		LED	Color	State	Condition
		Link	-	-	Off
Yellow	On		On	Link established	
	Blinking		Blinking	Data activity	
Speed	-	-	Off	10Mbps data rate or no link	
	Yellow	On	On	100Mbps data rate	
	Green	On	On	1Gbps data rate	

2.3 - 1GbE Networking Port LEDs

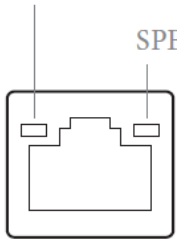
 ACT/LINK LED SPEED LED LAN Port		LED	Color	State	Condition
		Link	-	-	Off
Orange	On		On	Link established	
	Blinking		Blinking	Data activity	
Speed	-	-	Off	10Mbps data rate or no link	
	Yellow	On	On	100Mbps data rate	
	Green	On	On	1Gbps data rate	

2.4 - 10GbE Networking Port LEDs

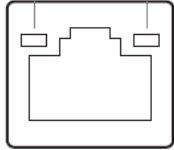
 ACT/LINK LED SPEED LED LAN Port		LED	Color	State	Condition
		Link	-	-	Off
Green			On	Link established	
			Blinking	Data activity	
Speed	-	-	Off	100 Mb/s data rate or no link	
	Yellow		On	1Gbps data rate	
	Green		On	10Gbps data rate	

2.5 - USB Ports

There are 4 USB 3.2 Gen 1 Type A ports on the Axial AC101 Edge Server.

Two ports are on the front of the system. Two ports are on the rear of the system.

All USB ports also support USB 2.0 connectivity.

2.6 - DisplayPort Video

There is one full-size DisplayPort (1.4a) located on the back of the Axial AC101 Edge Server.

2.7 - HDMI Video

There is one full-size DisplayPort (1.4a) located on the back of the Axial AC101 Edge Server.

2.8 - VGA Video

There is one full-size DisplayPort (1.4a) located on the back of the Axial AC101 Edge Server.

3 - Primary Component Connectors

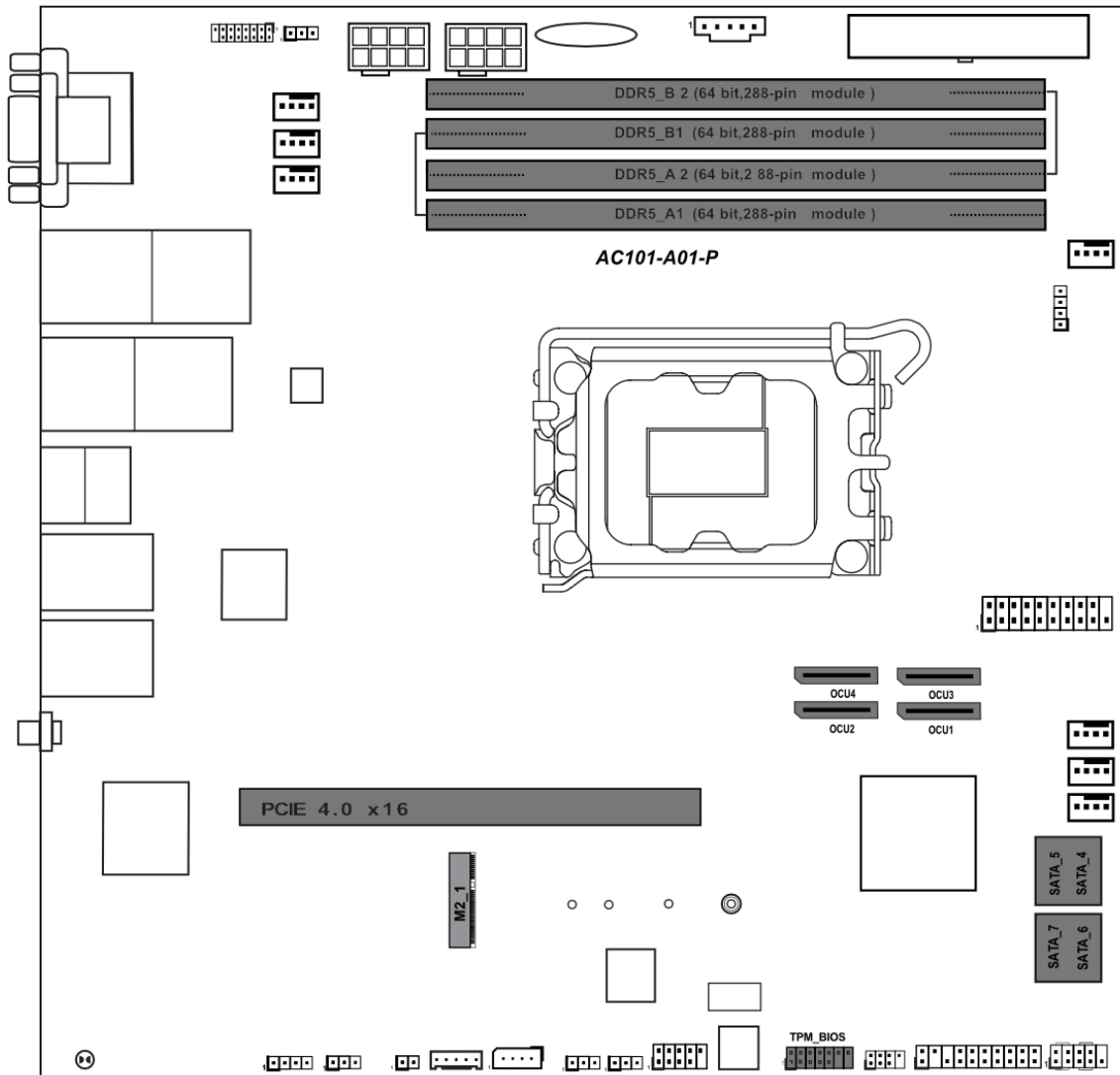

3.1 - M.2 2280/2260/2242/2230 M-key

This expansion slot is capable of supporting PCIe Gen 3 x4 and is routed directly to the W680 PCH. This slot is designed to support NVMe storage drives.

3.2 - TPM Header

The Axial AC101 supports an optional discrete TPM 2.0 module.

3.3 - SATA Headers

There are four SATA data headers on the Axial AC101 Edge Server motherboard.

The data ports support SATA III 6Gbps storage devices.

3.4 - OCUlink Headers

There are four OCUlink headers on the Axial AC101 Edge Server motherboard that support PCIe 4.0 x4 connections to enable NVMe drives.

3.5 - PCIe Gen 4.0 x16 Slot

The Axial AC101 features one PCIe Gen 4.0 x16 connector on the motherboard which is accessible by the use of a right angle riser card.

The PCIe riser card edge power draw of the slot is rated to support up to 75W as defined per PCI-SIG.

PCIe adapters up to 150W are supported when using the optional PCIe 6-Pin/8-Pin auxiliary power header.

3.6 - DDR5 UDIMM Slots

The Axial AC101 supports up to four DDR5 UDIMM slots rated up to 4400MHz.

- 4400MT/s @ 2DPC-1DIMM
- 4000MT/s @ 2DPC-2DIMM 1R
- 3600MT/s @ 2DPC-2DIMM 2R

The system will support both ECC and non-ECC memory with all supported CPU options.

3.6.1 - Supported Memory Modes

The IMC (Integrated Memory Controller) of the processors supports two memory modes, single-channel and dual-channel. The ability to support the memory modes is dependent upon the DIMM population.

3.6.1.1 - Single-Channel Mode

In this mode, all memory transactions occur within a single channel. Single-Channel mode is used when DIMMs are installed in either Channel A or Channel B, but not in both.

3.6.1.2 - Dual-Channel Mode – Intel® Flex Memory Technology Mode

In this mode, memory is divided into a symmetric and asymmetric zone. As per Intel documentation:

“The symmetric zone starts at the lowest address in each channel and is contiguous until the asymmetric zone begins or until the top address of the channel with the smaller capacity is reached. In this mode, the system runs with one zone of dual-channel mode and one zone of single-channel mode, simultaneously, across the whole memory array.”

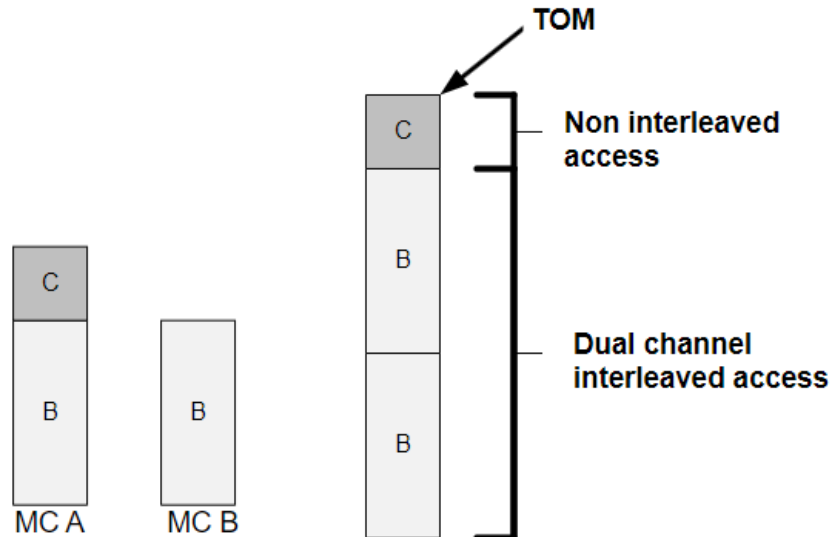

MC A and MC B can be configured to be physical channels 0 or 1
 B – The largest physical memory amount of the smaller size memory module
 C – The remaining physical memory amount of the larger size memory module

Source:

<https://edc.intel.com/content/www/us/en/design/ipla/software-development-platforms/client/platforms/alder-lake-desktop/12th-generation-intel-core-processors-datasheet-volume-1-of-2/system-memory-controller-organization-mode-ddr4-5-only/>

3.6.1.3 - Dual-Channel Symmetric Mode (Interleaved Mode)

Dual-Channel Symmetric mode is fully interleaved and provides the maximum performance.

The Axial AC101 will default to Dual-Channel Symmetric mode when both Channel A and Channel B DIMM connectors are populated in any order, with the total amount of memory in each channel being the same.

When both channels are populated with the same memory capacity and the boundary between the dual channel zone and the single channel zone is the top of memory, IMC operates completely in Dual-Channel Symmetric mode.

3.6.2 - DIMM Population Requirements

The following rules apply to when populating DIMMs in the Axial AC101 Edge Server

1. Only DDR5 DIMMs may be installed into the system.
2. The maximum frequency of the system memory will never exceed that of the lowest frequency DIMM DIMM(s) installed in the system.
3. Dual Channel Memory Mode is only supported with 2 or 4 DIMMs installed (split equally between Channel A and Channel B as indicated in the DIMM Population table).

When populating DIMMs within the system, the following population is recommended in order to maximize overall system performance:

# DIMMs	DDR5 A1	DDR5 A2	DDR5 B1	DDR5 B2	Memory Mode
1		Populated			Single Channel
2		Populated		Populated	Dual Channel (Symmetric mode)
3	Populated	Populated		Populated	Dual-Channel Mode (Flex Memory Technology Mode)
4	Populated	Populated	Populated	Populated	Dual Channel (Symmetric mode)

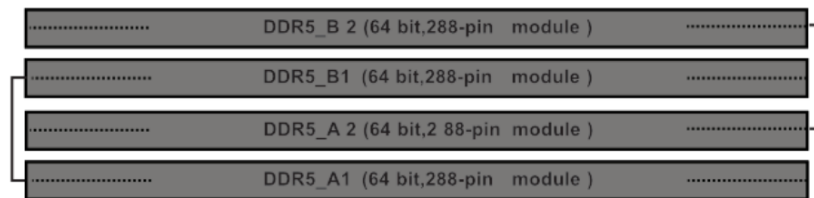

AC101-A01-P

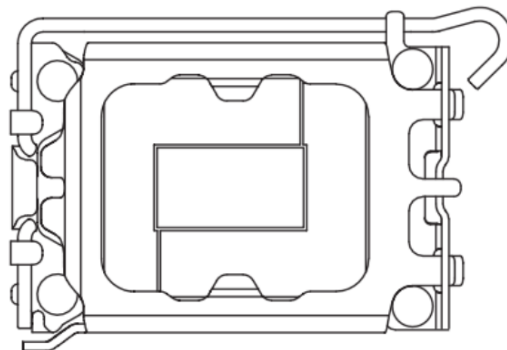

4 - Thermals and Cooling

The Axial AC101 Edge Server is designed to operate and function across a wide temperature (5 to 40°C) and humidity range (8 to 85% RH non-condensing). The following sections describe the thermals and cooling capabilities and behavior of the system.

4.1 - System Fans and Airflow Direction

The Axial AC101 Edge Server has five 40x40x56mm counter rotating system fans, which can be independently controlled and configured via the Baseboard Management Controller (BMC) relative to the supported system temperature sensors. The default fan duty and configuration settings have been validated to operate in accordance with the supported temperature range (up to 40°C). If the ambient operating temperature is tightly controlled, additional fan configuration optimizations may be manually adjusted to optimize acoustics and reduce power consumption. For additional information pertaining to manual fan configuration settings, please consult the Axial Edge Server BMC User Guide.

The power supply fans operate independently and have their own closed-loop cooling algorithm.

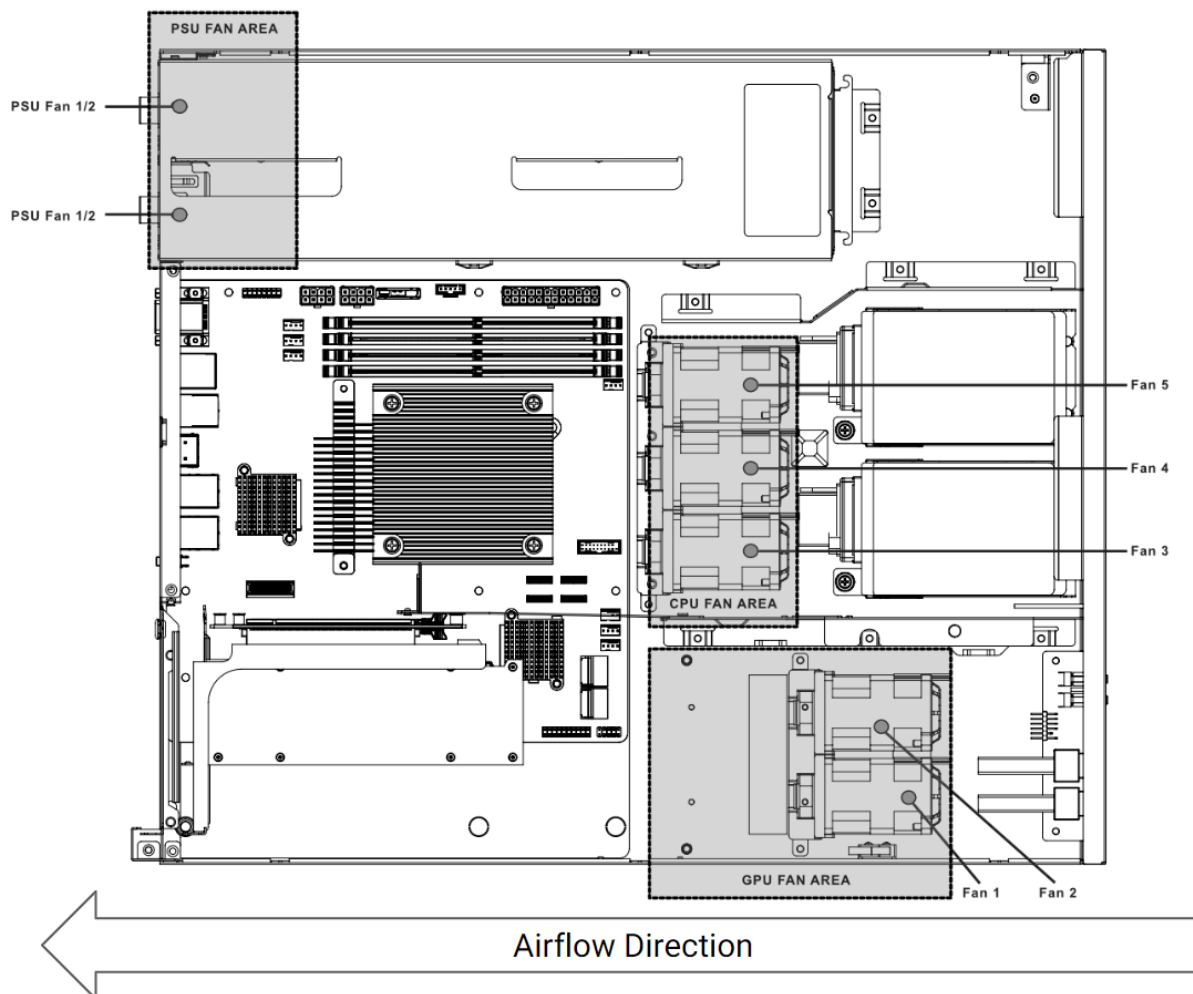

4.2 - Temperature Sensors

Temperature sensor data is available for a number of onboard temperature sensors.

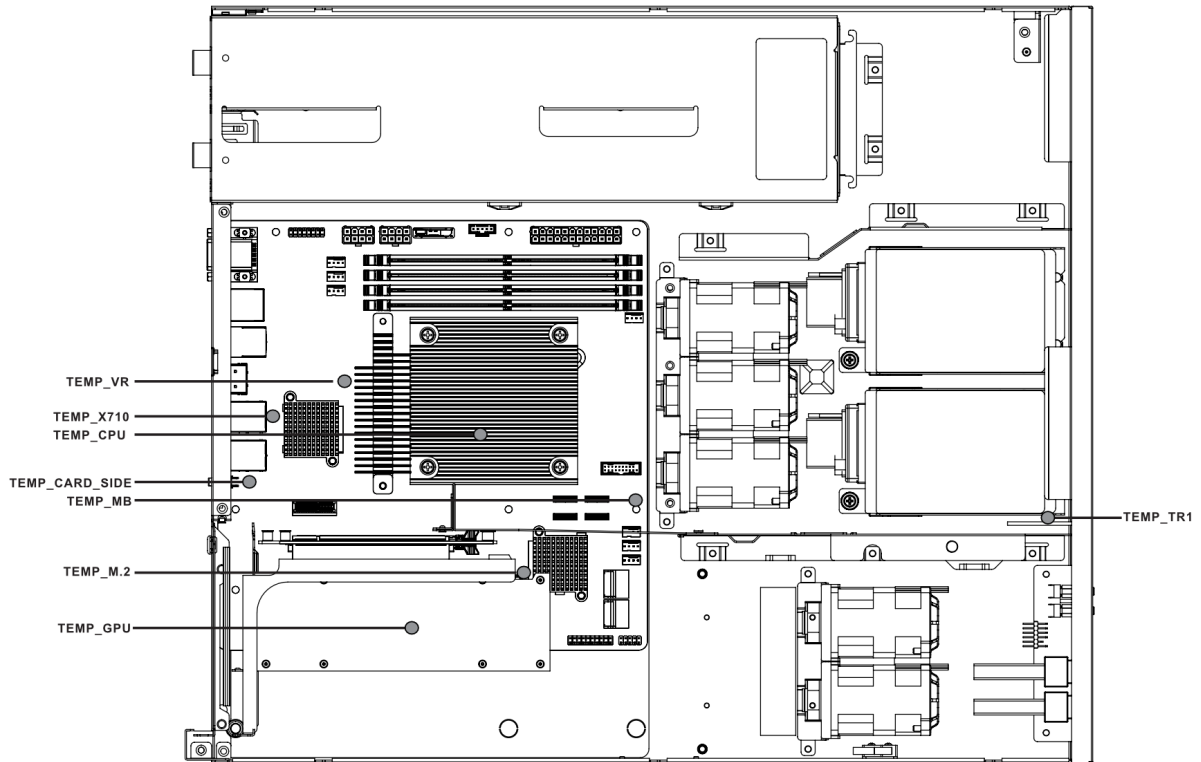

Sensor Name	Upper Non Critical Temperature °C	Upper Critical Temperature °C
TEMP_MB	54	55
TEMP_CPU	TjMax - 1	TjMax
TEMP_VR	99	100
TEMP_CARD_SIDE	69	70
TEMP_X710	99	100
TEMP_TR1	65	
TEMP_M.2	70	
TEMP_GPU	92	93

4.3 - Default Fan Settings

The system is configured to operate in accordance with a closed loop thermal algorithm which accommodates for components temperature maximums, reduced acoustics, lower power consumption, and optimal performance.

4.3.1 - Fan Zone Assignments

The fan zone assignments, default closed loop tables, and associated temperature sensors are outlined in this section.

4.3.1.1 - Fan Zone 1 - CPU Area

Assigned Temperature Sensor: TEMP_CPU

Assigned Fans: FAN3, FAN4, FAN5

Closed Loop Table 1	Value
Ramp Up Temp (°C)	80
Ramp Up Interval (sec)	3
Ramp Up Duty (%)	1
Ramp Down Temp (°C)	75
Ramp Down Interval (sec)	3
Ramp Down Duty (%)	3
Ramp Threshold (°C)	0

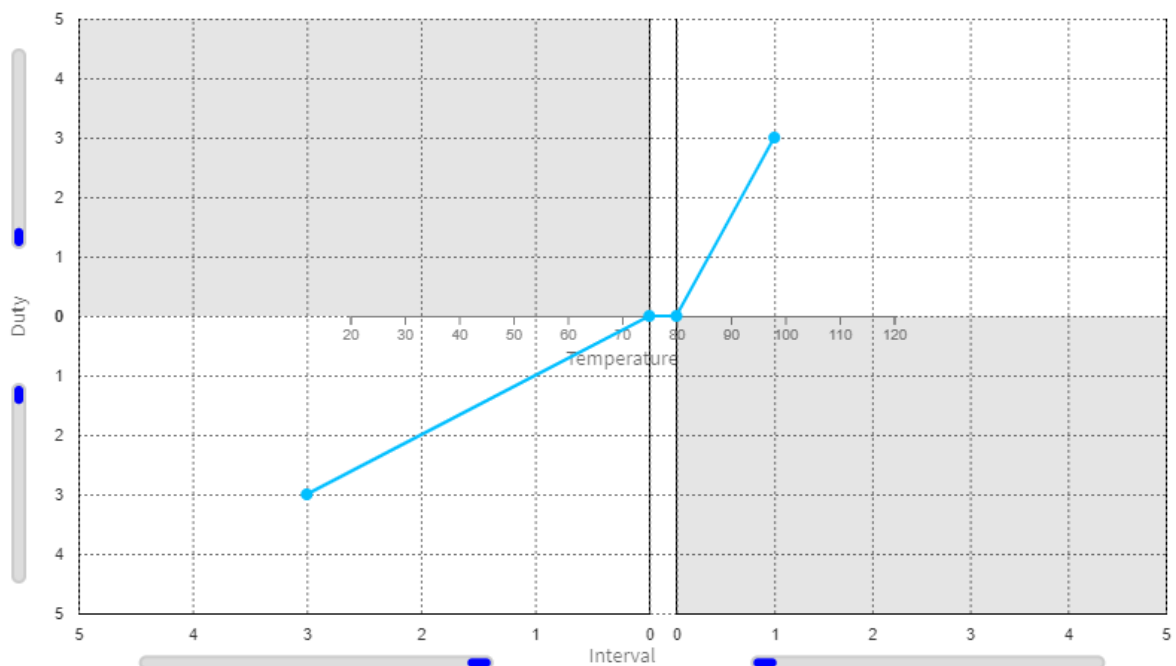

As per the default configuration settings, the system fans will increase duty cycle at 3% increments every 1 seconds when the CPU temperature is at or above 80°C. When the temperature drops below 75°C, the system fan duty cycle will reduce 3% every 3 seconds.

4.3.1.2 - Fan Zone 2 - PCIe / GPU Area

Assigned Temperature Sensor: TEMP_GPU

Assigned Fans: FAN1, FAN2

Closed Loop Table 2	Value
Ramp Up Temp (°C)	86
Ramp Up Interval (sec)	2
Ramp Up Duty (%)	3
Ramp Down Temp (°C)	76
Ramp Down Interval (sec)	1
Ramp Down Duty (%)	3
Ramp Threshold (°C)	0

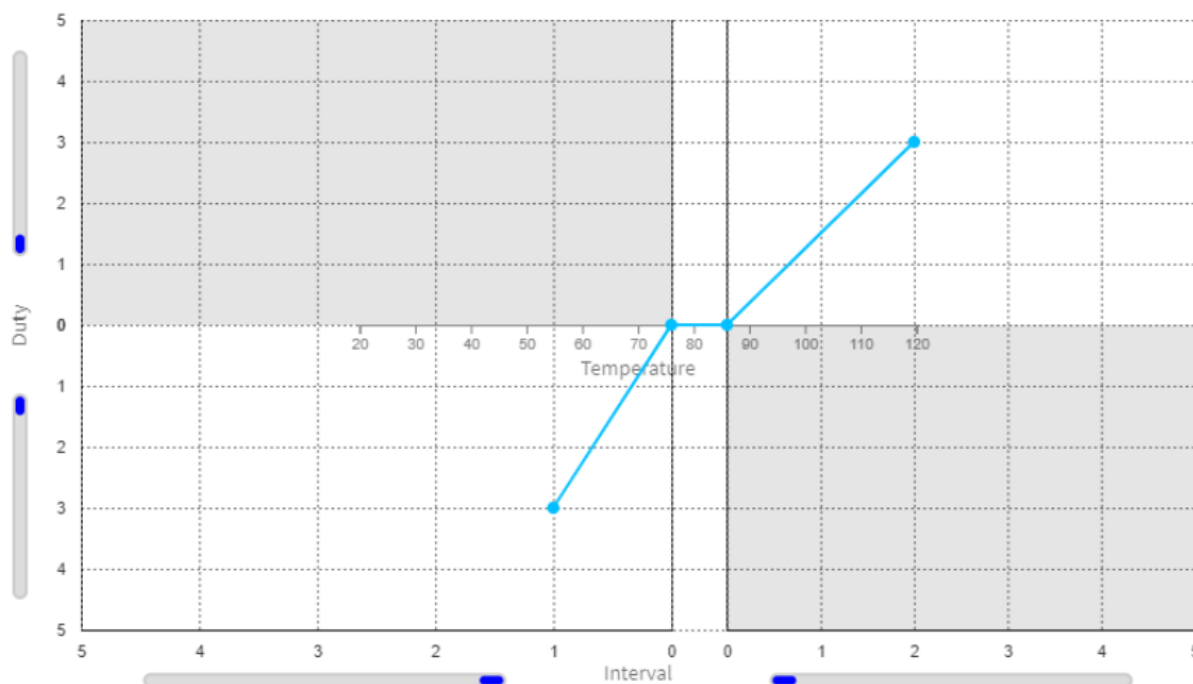

As per the default configuration settings, the system fans will increase duty cycle at 3% increments every 2 seconds when the GPU temperature is at or above 86°C. When the temperature drops below 76°C, the system fan duty cycle will reduce 3% every 1 second.

Note: GPU temperature sensing is only supported with Nvidia professional grade GPUs

4.3.2 - Additional Fan Defaults

The default system idled duty cycle is 5%.

Upon System Fan Failure or BMC Firmware Update, System Fans will ramp to maximum speed.

4.4 - Thermal Performance and Validation

As previously noted, the default fan duty and configuration settings have been validated to operate in accordance with the supported temperature range (up to 40°C) as per the following test scenario and results.

4.4.1 - Test Conditions

- Temperature Range: 5°C to 40°C (+5)
- System Configuration:
 - i9-13900TE Processor (125W PL2)
 - Performance-core Max Turbo Frequency: 5.00 GHz
 - Efficient-core Max Turbo Frequency: 3.90 GHz
 - Performance-core Base Frequency: 1.00 GHz
 - Efficient-core Base Frequency: 800 MHz
 - 2 TB PCIe Gen4 x4 m.2 Storage
 - 4 PCIe 4.0 2.5" Storage Drives
 - 128GB DDR5 Memory
 - Nvidia T1000 GPU
 - Max Boost Frequency: 2100 MHz
 - Base Frequency: 1065 MHz
- Workload Applications/Test:
 - Memory 80% workload with PassMark BurnInTest
 - Storage 80% workload with PassMark BurnInTest
 - 3D Graphics 80% workload with PassMark BurnInTest
 - Processor loaded 100% with Intel XTU

- Discrete GPU loaded with Nvidia Nbody

4.4.2 - Test Results

The Axial AC101 system sustained a full processor workload and 80% workloads on memory, storage and 3D graphics, along with executing an Nbody simulation through its full rated temperature range without throttling and while maintaining greater than base clocks on all processor cores and GPU cores. During the test sequence numerous points throughout the system were monitored to ensure adequate cooling was provided to components in the system. The system was also tested 5°C above and below its rated temperature range to help classify performance outside of the rated temperature range.

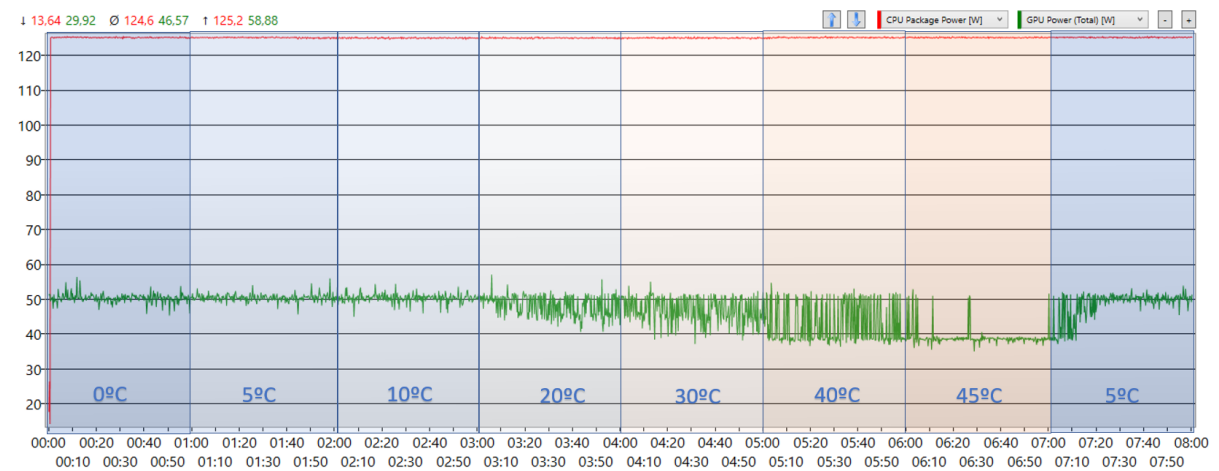
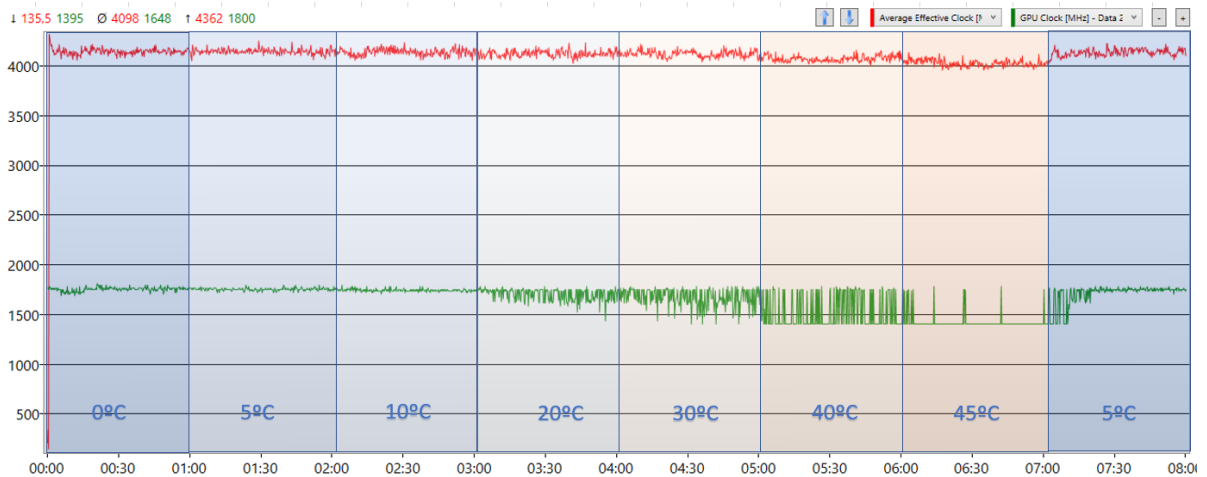

5 - Power

The sections below focus on the power features and capabilities of the Axial AC101 Edge Server.

5.1 - Supported Power Supplies

The system supports two redundant power supplies, which may either be 450W or 750W. These power supplies are hot-swappable, meaning they can be replaced while the system is running without interrupting its operation.

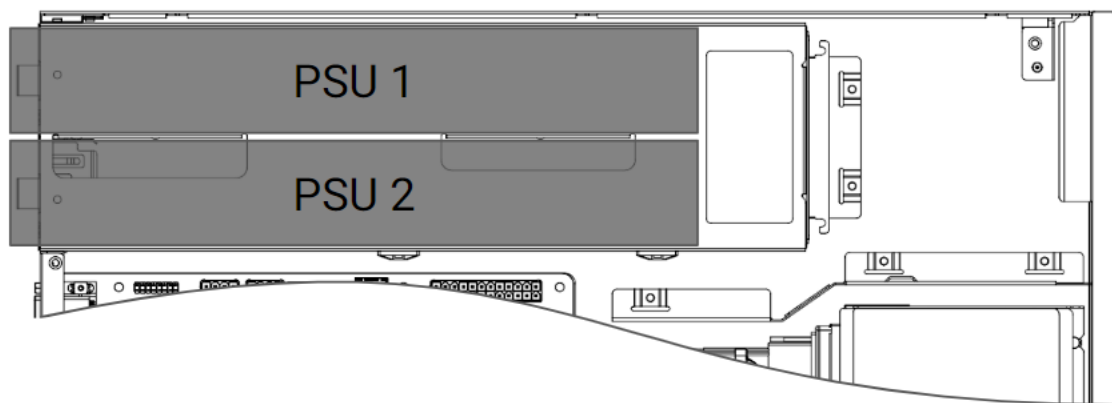

It is important to note that the two power supplies must be of the same wattage. Mixing power supplies of different wattages is not allowed. Please ensure that both power supplies are of the same wattage before installing them into the system.

If you need to replace a failed power supply, simply remove the failed unit and insert a new one of the same wattage. The system will automatically recognize the replacement power supply and bring it online to restore redundancy.

5.2 - Power Redundancy

The power supplies in this system are fully redundant in a primary/backup mode. This means that the two power supplies work in parallel, with one power supply acting as the primary source of power and the other as a backup.

In normal operation, the primary power supply is responsible for supplying power to the system, while the backup power supply remains idle. If the primary power supply fails, the backup power supply automatically takes over, ensuring that the system continues to receive power without interruption.

The power supplies are designed to work seamlessly together, with the primary power supply handling the majority of the load and the backup power supply providing additional power as needed.

This redundancy ensures that the system can continue to operate even if one power supply fails, providing a high level of reliability for critical systems.

If a power supply failure occurs, the alerts will be presented via the Baseboard Management Controller (BMC) or an audible alarm may occur. If this happens, the failing supply can be serviced while the system remains operational on the backup power supply. Once the replacement power supply is installed, the system will automatically detect it and bring it online, restoring full redundancy.

5.3 - Wake-Up Events

Axial AC101 supports multiple power states.

Wake-Up Event	From ACPI State	Comments
Power Button	Deep S5 , S5, S4	
PCIE/LAN	S5*, S4, S3	Must be enabled in BIOS
USB Keyboard/Mouse/Remote	S3	Must be enabled in BIOS
RTC Alarm	S5	Must be enabled in BIOS

* Onboard Intel® X710 Network controller only supports wake from S5

Note: The Power LED is off when the system is in S4 sleep state or powered off (S5).

6 - Operating Systems

The Axial AC101 Edge Server supports the following operating systems:

- Microsoft Windows 10 IoT Enterprise 2021 LTSC Value (Celeron/i3/i5) - 64 Bit
- Microsoft Windows 10 IoT Enterprise 2021 LTSC High End (i7/i9/Xeon) - 64 Bit
- Microsoft Windows 11 Professional 64-bit

6.1 - Windows 10 IoT Enterprise 2021 LTSC Licensing

Windows 10 IoT LTSC (Long-Term Servicing Channel) is a version of the Windows 10 operating system designed for use in embedded and IoT (Internet of Things) devices.

For information pertaining to the benefits of Windows 10 IoT, please refer to the following: [Windows 10 IoT and its Benefits for Businesses](#).

The 2021 version of Windows 10 IoT LTSC comes in two licensing editions that are supported and may be preloaded on to the Axial AC101 Edge Server:

- Microsoft Windows 10 IoT Enterprise 2021 LTSC Value
 - This version of Windows 10 IOT is suitable for systems with Intel Core-i3 and Core-i5 processors.
- Microsoft Windows 10 IoT Enterprise 2021 LTSC High End
 - This version of Windows 10 IOT is suitable for systems with Intel Core-i7 and Core-i9

Both versions support Azure IoT Edge for Linux on Windows (EFLOW), allowing for containerized Linux workloads alongside Windows applications in Windows deployments. For additional information, see [What is Azure IoT Edge for Linux on Windows](#) from Microsoft.

7 - Mounting Hardware

The Axial AC101 Edge Server has been designed with flexibility in mind and can be mounted in different ways. As the system is designed to meet industry standard 19" Electronic Industries Alliance (EIA) racks, there are multiple rack mounting rail kits available. Additionally, the system may also be wall mounted using the OnLogic wall mount kit.

7.1 - Rack Mounting

The Axial AC101 Edge Server has been designed to support standard 19" EIA rack mounting, which is a common form factor used in data centers and server rooms. To accommodate different rack depths, the system supports 23" and 28" rail kits that can be used to securely mount the server in the rack. These rail kits are easy to install and include all the necessary hardware for attachment into the rack.

7.1.1 - Rackmount 23" Ball Bearing Slide Rails

The 23" Ball Bearing Slide Rails are an optional accessory designed to enhance the functionality and ease of use of the Edge Server. These slide rails are designed to be used with standard 19" EIA racks and allow for easy installation and removal of the server from the rack. The ball bearing design ensures smooth and effortless sliding motion, while the sturdy construction provides a secure and stable platform for the server. With these slide rails, you can easily access the server for maintenance or upgrades without the need for complex disassembly or cumbersome lifting.

The 23" Ball Bearing Slide rail kit can be chosen at time of configuration based on the rack depth requirements.

Mounting Hole: Square, **Rack Depth Range (front to back flange):** 597mm (23.5in) to 927mm (36.5in)

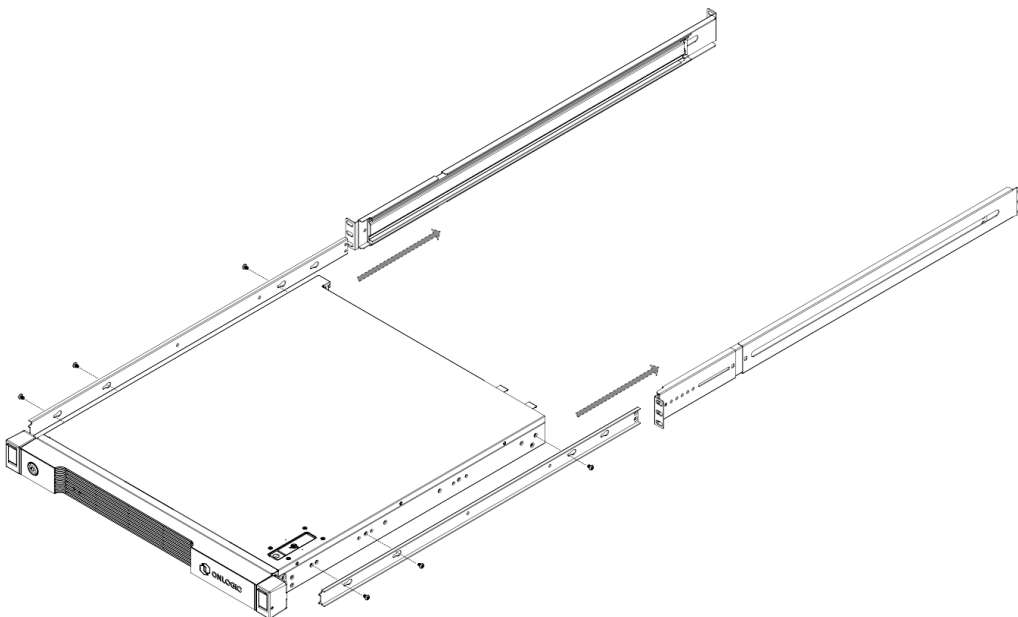

Install the six M4x0.7 L=4mm Low Profile Cheesehead screws provided with the rail kit

7.1.2 - Rackmount 23" Ball Bearing Cable Management Arm Slide Rail Kit

The 23" Ball Bearing Cable Management Arm Slide Rail Kit is an optional accessory that enhances the standard ball bearing slide rail options by providing a cable management arm to neatly organize and secure cable connections to the Edge Server system while still supporting easy removal of the server from the rack for maintenance and upgrades.

The 23" Ball Bearing Slide rail kit can be chosen at time of configuration based on the rack depth requirements.

Mounting Hole: Square, **Rack Depth Range (front to back flange):** 597mm (23.5in) to 927mm (36.5in)

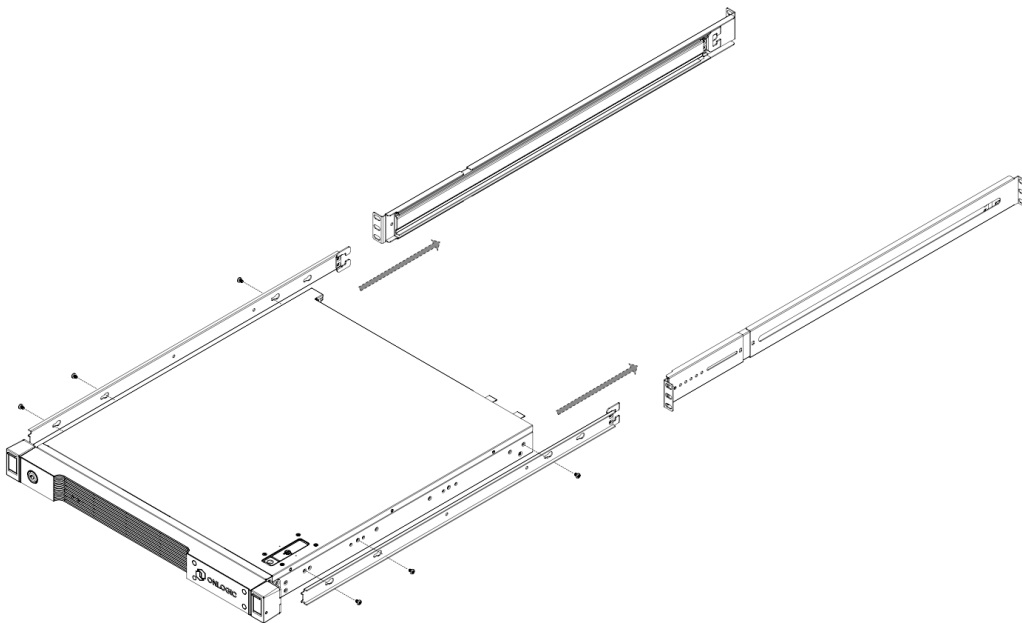

Install the six M4x0.7 L=4mm Low Profile Cheesehead screws provided with the rail kit

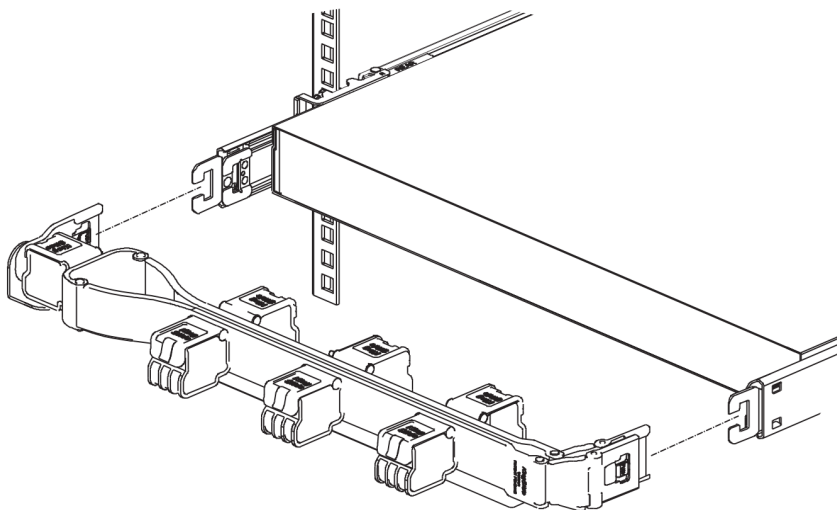

7.1.3 - Rackmount 28" Simple Locking Ball Bearing Slide Rails

The 28" Simple Lock Ball Bearing Slide Rails are an optional accessory designed to enhance the functionality and ease of use of the Edge Server. These slide rails are designed to be used with standard 19" EIA racks and allow for easy installation and removal of the server from the rack. The ball bearing design ensures smooth and effortless sliding motion, while the sturdy construction provides a secure and stable platform for the server.

With these slide rails, you can easily access the server for maintenance or upgrades without the need for complex disassembly or cumbersome lifting.

The simple locking mechanism allows for quick mounting into a rack without the use of any tools.

The 28" Simple Lock Ball Bearing Slide rail kit can be chosen at time of configuration based on the rack depth requirements.

Mounting Hole: Square, **Rack Depth Range (front to back flange):** 609mm (24in) to 921mm (36.2 in)

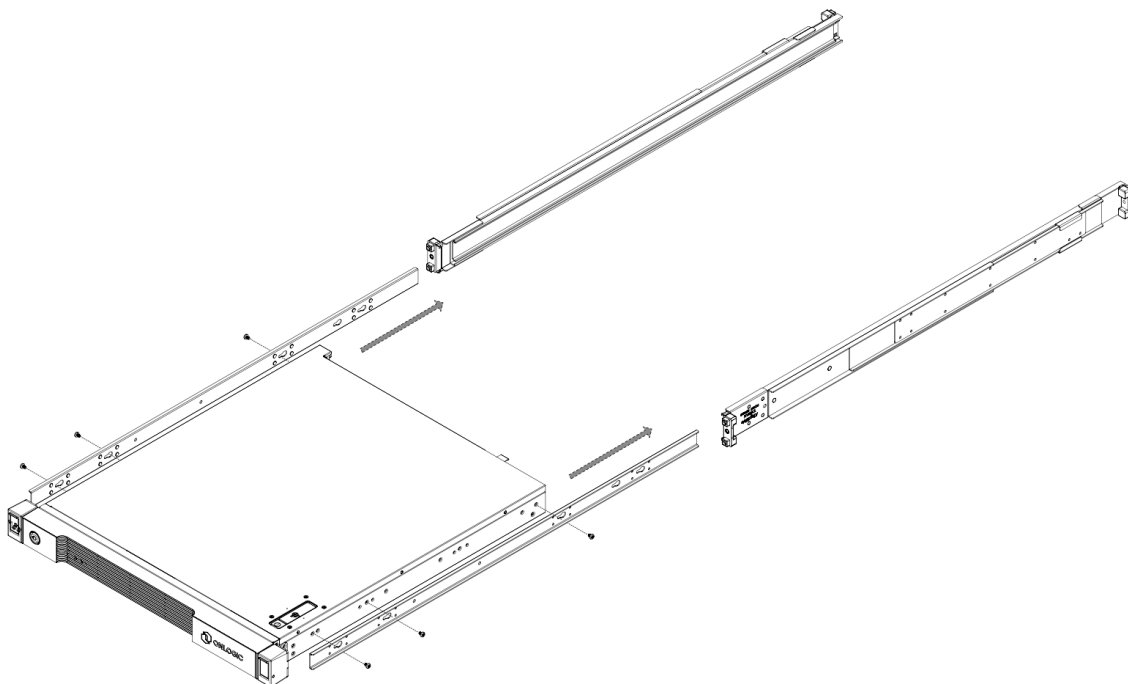

Install the six M4x0.7 L=4mm Low Profile Cheesehead screws provided with the rail kit

7.2 - Wall Mounting

7.2.1 - Wall mount kit

The Axial AC101 Edge Server wall mount kit is made of sturdy metal and designed to securely hold the server in place against a wall. This optional accessory includes the necessary wall mounting brackets and hardware to flexibly mount the Axial AC101 Edge Server system where a rack is not available or practical.

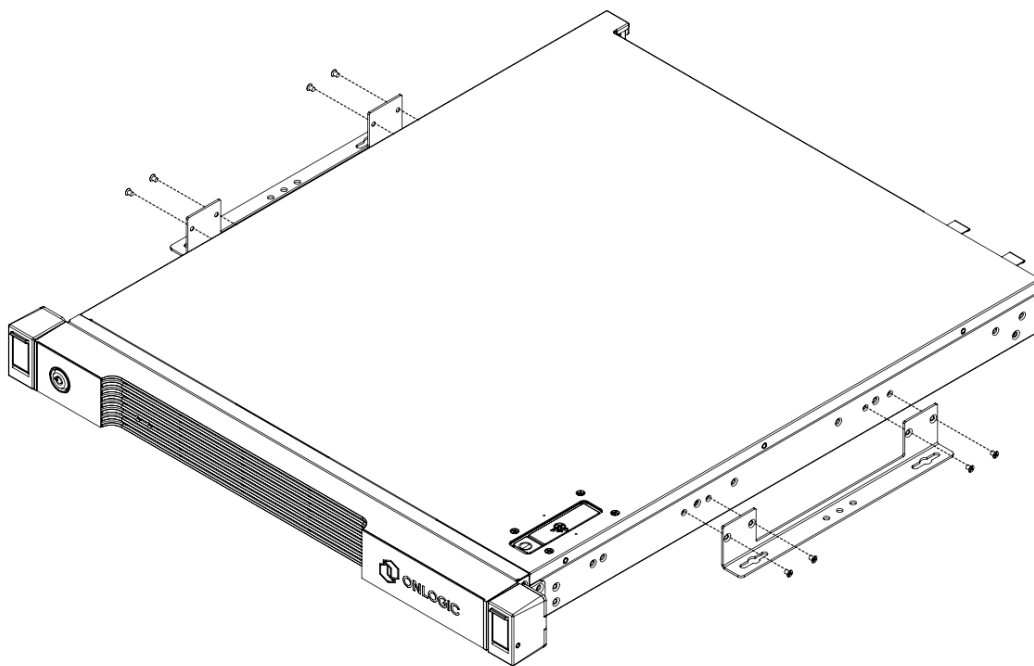

Install the eight M3x0.5 L=4mm Flathead screws provided with the wall mount kit

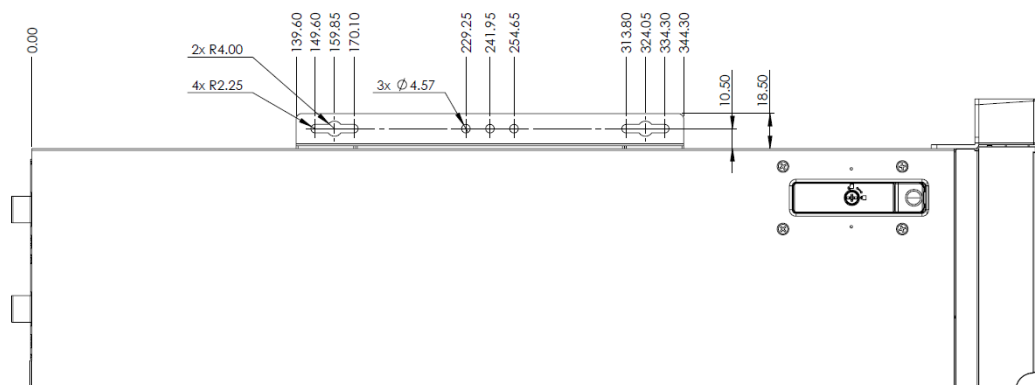

8 - Regulatory Compliance

8.1 - CE

The computer system was evaluated for IT equipment EMC standards as a class A device.

The computer complies with the relevant IT equipment directives for the CE mark.

Modification of the system may void the certifications. Testing includes: EN 55032, EN 55035, EN 60601-1, EN 62368-1, EN 60950-1.

8.2 - FCC Statement

This device complies with part 15 of the FCC rules as a Class A device. Operation is subject to the following two conditions: (1) this device may not cause harmful interference and (2) this device must accept any interference received, including interference that may cause undesired operation.

8.3 - ISED

This device complies with Industry Canada license-exempt RSS standard(s). Operation is subject to the following two conditions: (1) this device may not cause interference, and (2) this device must accept any interference, including interference that may cause undesired operation of the device.

Le présent appareil est conforme aux CNR d'Industrie Canada applicables aux appareils radio exempts de licence. L'exploitation est autorisée aux deux conditions suivantes: (1) l'appareil ne doit pas produire de brouillage, et (2) l'utilisateur de l'appareil doit accepter tout brouillage radioélectrique subi, même si le brouillage est susceptible d'en compromettre le fonctionnement.

CAN ICES-003(A) / NMB-003(A)

8.4 - UKCA

The computer system was evaluated for medical, IT equipment, automotive, maritime and railway EMC standards as a class A device. The computer complies with the relevant IT equipment directives for the UKCA mark.

9 - Appendices

9.1 - Appendix A: Technical Support

Additional technical support and information can be found on our support website at the following link:

<https://support.onlogic.com/documentation/>

9.2 - Appendix E: Compliance Information

Do not open or modify the device. The device uses components that comply with FCC and CE regulations. Modification of the device may void these certifications.

9.2.1 - Safe use and installation instructions

1. Install the device securely. Be careful handling the device to prevent injury and do not drop.
2. Equipment is intended for installation in a Restricted Access Area.
3. Elevated Operating Ambient - If installed in a closed or multi-unit rack assembly, the operating ambient temperature of the rack environment may be greater than room ambient. Therefore, consideration should be given to installing the equipment in an environment compatible with the maximum ambient temperature (T_{ma}) specified by the manufacturer.
4. Reduced Air Flow - Installation of the equipment in a rack should be such that the amount of air flow required for safe operation of the equipment is not compromised.
5. Mechanical Loading - Mounting of the equipment in the rack should be such that a hazardous condition is not achieved due to uneven mechanical loading.
6. Circuit Overloading - Consideration should be given to the connection of the equipment to the supply circuit and the effect that overloading of the circuits might have on overcurrent protection and supply wiring. Appropriate consideration of equipment nameplate ratings should be used when addressing this concern.
7. Reliable Earthing - Reliable earthing of rack-mounted equipment should be maintained. Particular attention should be given to supply connections other than direct connections to the branch circuit (e.g. use of power strips).
8. Ambient operating temperature must be between 5 °C to 40 °C with a non-condensing relative humidity of 8-85%.
9. The device can be stored at temperatures between -40 °C to 70 °C.
10. Keep the device away from liquids and flammable materials.
11. Do not clean the device with liquids. The chassis can be cleaned with a cloth.
12. Allow at least 2 inches of space around all sides of the device for proper cooling. If the device is mounted to a vertical surface then recommended device orientation is so that heatsink fins allow air to rise unobstructed. Alternative orientations may result in reduced operational temperature range.
13. This device is intended for indoor operation only.
14. Install the device only with shielded network cables.
15. Service and repair of the device must be done by qualified service personnel. This includes, but is not limited to, replacement of the CMOS battery. Replacement CMOS battery must be of the same type as the original.
16. Proper disposal of CMOS battery must comply with local governance.
17. Product must only be connected to a certified router, switch or similar network equipment.
18. Product is intended for indoor use only.
19. Product cannot be connected to the public network.



WARNING: There is danger of explosion if the CMOS battery is replaced incorrectly. Disposal of battery into fire or a hot oven, or mechanically crushing or cutting of a battery can result in an explosion.

9.2.2 - Précautions et guide d'installation

Ne pas ouvrir ou modifier l'appareil. L'appareil utilise des composants conformes aux réglementations FCC et EC. La modification de l'appareil peut annuler ces certifications.

1. Installez l'appareil en toute sécurité. Manipulez l'appareil avec précaution pour éviter de vous blesser et ne le laissez pas tomber.
2. L'équipement est destiné à être installé dans une zone à accès restreint.
3. Température ambiante de fonctionnement élevée - En cas d'installation dans un rack fermé ou à plusieurs unités, la température ambiante de fonctionnement de l'environnement du rack peut être supérieure à la température ambiante de la pièce. Par conséquent, il convient de veiller à installer l'équipement dans un environnement compatible avec la température ambiante maximale (T_{ma}) spécifiée par le fabricant.
4. Débit d'air réduit - L'installation de l'équipement dans un rack doit être telle que la quantité de débit d'air requise pour un fonctionnement sûr de l'équipement ne soit pas compromise.
5. Chargement mécanique - Le montage de l'équipement dans le rack doit être tel qu'une condition n'est pas atteinte en raison d'une charge mécanique inégale.
6. Surcharge de circuit - Il convient de tenir compte de la connexion de l'équipement au circuit d'alimentation et de l'effet que la surcharge des circuits pourrait avoir sur la protection contre les surintensités et le câblage d'alimentation. Une prise en compte appropriée des valeurs nominales de la plaque signalétique de l'équipement doit être utilisée pour répondre à cette préoccupation.
7. Mise à la terre fiable - Une mise à la terre fiable de l'équipement monté en rack doit être maintenue. Une attention particulière doit être accordée aux raccordements d'alimentation autres que les raccordements directs au circuit de dérivation (par exemple, utilisation de multiprises).
8. La température ambiante de fonctionnement doit être comprise entre 5 °C et 40 °C avec une humidité relative sans condensation de 8 à 85 %.
9. L'appareil peut être stocké à des températures comprises entre -40 °C et 70 °C.
10. Gardez l'appareil à l'écart des liquides et des matériaux inflammables.
11. Ne nettoyez pas l'appareil avec des liquides. Le châssis peut être nettoyé avec un chiffon.
12. Laissez au moins 2 pouces d'espace autour de tous les côtés de l'appareil pour un refroidissement correct. Si l'appareil est monté sur une surface verticale, l'orientation recommandée de l'appareil est de sorte que les ailettes du dissipateur thermique permettent à l'air de monter sans obstruction. Des orientations alternatives peuvent entraîner une plage de températures de fonctionnement réduite.
13. Cet appareil est destiné à une utilisation en intérieur uniquement.
14. Installez l'appareil uniquement avec des câbles réseau blindés.
15. L'entretien et la réparation de l'appareil doivent être effectués par un personnel qualifié. Cela inclut, mais sans s'y limiter, le remplacement de la batterie CMOS. La batterie CMOS de remplacement doit être du même type que celle d'origine.
16. L'élimination appropriée de la batterie CMOS doit être conforme à la gouvernance locale.
17. Le produit doit uniquement être connecté à un routeur, un commutateur ou un équipement réseau similaire certifié.
18. Le produit est destiné à une utilisation en intérieur uniquement.
19. Utilisez uniquement des connecteurs répertoriés UL pour la connexion aux panneaux de fusibles automobiles.
20. Le produit ne peut pas être connecté au réseau public.



ATTENTION: Il existe un risque d'explosion si la pile CMOS n'est pas remplacée correctement. L'élimination de la batterie dans le feu ou dans un four chaud, ou l'écrasement ou le découpage mécanique d'une batterie peut entraîner une explosion.

End of Document