

HX310 / HX330 Industrial Computer

Product Manual

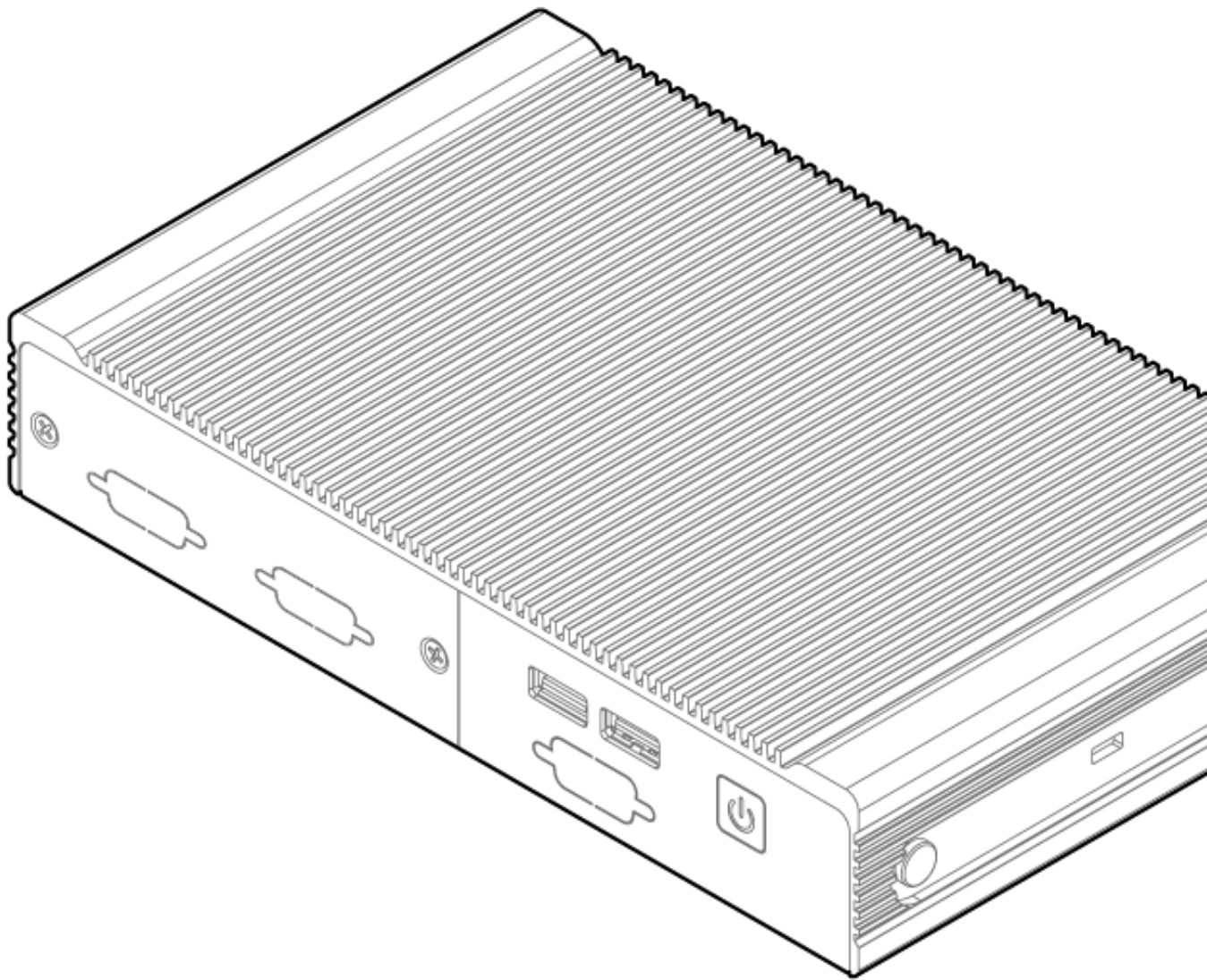

Revision History

Revision History	Date
First release of HX300 manual	8/4/2021
Update errata list	8/12/2021
Update including radio transmitter info, VCCI, RF, Safety info, and power supply info	1/25/2022
CEC Module Removal	04/21/2022
Updated Drawings	05/13/2022
Update Graphs & Appendices	07/28/2022
Updating SIM Slot Info	09/15/2022
Update errata list	01/10/2023
Serial Port Clarification	4/27/2023

Table of Contents

1 - System Overview	5
1.1 - System Introduction	5
1.2 - In-box Accessories	5
1.3 - Product Specifications	6
1.4 - Exterior Features and Dimensions	9
1.4.1 - Front I/O	9
1.4.2 - Back I/O	9
1.4.3 - Helix 300 Dimensions (HX310 / HX330)	10
1.5 - System Block Diagram	11
2 - I/O Definitions	12
2.1 - Front I/O Definition	12

2.2 - Rear I/O definition	17
2.3 - Motherboard Connectors	20
3 - Mounting Instructions	29
3.1 - Wall Mount & DIN Rail Mounting	29
3.1 - VESA Mounting	32
4 - Power Management	33
4.1 - Wake-Up Events	33
4.2 - Protection Circuitry	33
5 - Regulatory Compliance	34
CE	34
FCC Statement	34
ISED (Innovation, Science and Economic Development Canada)	34
UKCA	34
VCCI	34
6. - Appendices	35
6.1 - Appendix A: Power consumption	35
6.2 - Appendix B: Isolated DIO guide	37
6.3 - Appendix C: BIOS manual	37
6.4 - Appendix D: CAN user guide	37
6.5 - Appendix E: System thermal results	37
6.6 - Appendix F: Expansion port pinout	40
6.6.1 - M.2 B-Key	40
6.6.2 - M.2 E-Key	41
6.6.3 - M.2 M-Key	42
6.7 - Appendix G: Safety Information	43
6.7.1 Safe use and installation instructions	43
6.7.2 Précautions et guide d'installation	44

6.8 - Appendix H: Errata	45
6.8.1 IP-1: RS422 and RS485 Require SerCx2	45
Overview	45
Description	45
Workaround	45
Resolution	45
6.8.2 IP-2: System May Power On After Power Interruption	45
Overview	45
Description	46
Workaround	46
Resolution	46
6.8.3 IP-3: Wake-On-LAN Does Not Function	46
Overview	46
Description	46
Workaround	46
Resolution	46

1 - System Overview

1.1 - System Introduction

The Helix 300 Series harnesses the enhanced power and capabilities of Intel "Elkhart Lake" Celeron and Pentium processors in a low profile fanless system built for the challenges of the IoT edge. With support for triple independent 4K displays, a 0°C to 50°C operating temperature range, and a wealth of configuration options, the Helix 310 and Helix 330 were engineered with versatility in mind. The systems also feature compliance testing for IT Equipment EMC and Safety and pre-compliance testing for IEC 60601-1-2 (4th edition) medical immunity.

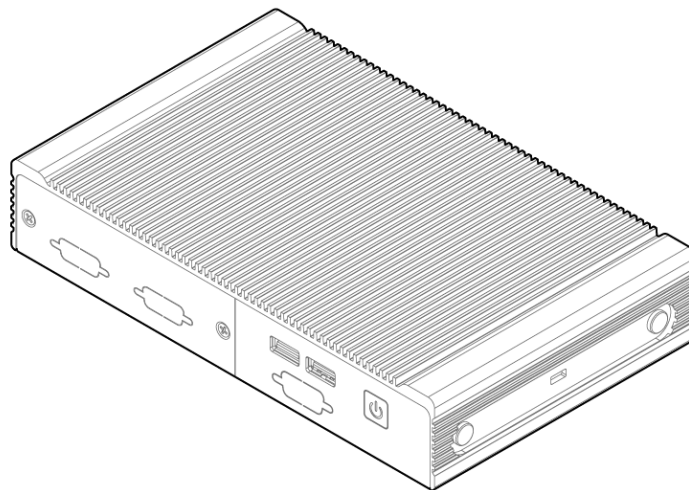

1.2 - In-box Accessories

- 4x Rubber Feet
- Power cable retention

If you purchased additional items such as mounting brackets, power supplies or terminal block connectors, they will be located in the system box or within the outer shipping carton.

All drivers and product guides can be found on the corresponding product page. For more information on accessories and additional features, visit the Helix Product pages.

Helix 310 Product Page: <https://www.onlogic.com/hx310/>

1.3 - Product Specifications

Model	HX310	HX330
System Dimensions	196x37x120 mm (TBD)	same
Motherboard Dimensions	114 x 175 mm max (TBD)	same
CPU	Celeon N6211 6W, 2 Cores or Pentium J6426 - 10 W, 4 Cores	Celeon N6211 6W, 2 Cores or Pentium J6426 - 10 W, 4 Cores
Memory	2 x SO-DIMM (2 x 16 max Dual Channel) 32 GB Total	2 x SO-DIMM (2 x 16 max Dual Channel) 32 GB Total
LAN controller	1x Intel GPY115 or 2x Intel GPY115 with Pentium J6426	1x Intel GPY115 or 2x Intel GPY115
Expansion	1x M.2 2280/60/3042 B-Key (PCIe x 1, USB 3.0, SATA III) 1x M.2 2230 E-key (Wi-Fi) (PCIe / USB 2.0) 1x M.2 2280 M-key (PCIe x 2, SATA III)	1x M.2 2230 E-key (Wi-Fi) (PCIe / USB 2.0) 1x M.2 2280 M-key (PCIe x 2, SATA III)
Optional Add On Module	4G/5G, CAN Bus	Dual LAN
Back I/O	3x Full size DisplayPort 1.4 1 x Gb LAN (2 Gb LAN optional with Pentium J6426) 2x USB 3.1 (Host Gen 2) 2x USB 2.0 Terminal Block Option - Punch out 3x Antenna punch outs Barrel Jack with 12~24 V input 1x Kang Yang SWPL-3 (Power Cable Retention) Kensington Lock	3x Full size DisplayPort 1.4 1 x Gb LAN (2 Gb LAN optional with Pentium J6426) 2x USB 3.1 (Host Gen 2,) 2x USB 2.0 Terminal Block Option - Punch Out 3x Antenna punch outs Barrel Jack with 12~24 V input 1x Kang Yang SWPL-3 (Power Cable Retention) Kensington Lock
Front I/O	1x Power LED button (recessed power button) 1x USB 2.0 1x USB 3.1 (Host Gen 2) 3FF-Sim slot (Mapped to the B-Key) 1x Serial port (DB9 RS-232/422/485)*	1x Power LED button (recessed power button) 2x Gb LAN 1x USB 2.0 1x USB 3.1 (Host Gen 2) 3FF-Sim slot (Mapped to the B-Key) 1x Serial port (DB9 RS-232/422/485)*
ModBay (Front plate)	2x COM DB9 RS-232/422/485 or CANBus 3 antenna punch outs 10-pin terminal block (for 8-pin DIO)	Dual LAN RJ45
Onboard Headers & Connectors	1x Battery on a cable 2x Serial Header, RS 232/422/485 1x USB 2.0 (1x5 header) 1x 2-Pin power for devices 5V (J32) 4 Pin in for Terminal Block Power	1x Battery on a cable 2x Serial Header, RS 232/422/485 1x USB 2.0 (1x5 header) 1x 2-Pin power for devices 5V (J32) 4 Pin in for Terminal Block Power

	Auto Power On (AT/ATX Mode Select) 2x6 connector for GPIO x 8 with Interrupt (including 1 pin power, 2 pin ground, 1 keyed) CAN-FD Bus 2x5-pin header with key (to use standard DB9 cable)	Auto Power On (AT/ATX Mode Select) 2x6 connector for GPIO x 8 with Interrupt (including 1 pin power, 2 pin ground, 1 keyed) CAN-FD Bus 2x5-pin header with key (to use standard DB9 cable)
Voltage Input	rated input: 8~24V via DC jack or onboard 4-pin power header; +/- 10% tolerance	rated input: 8~24V via DC jack or onboard 4-pin power header; +/- 10% tolerance
Power Input	Barrel Jack with optional 4-pin Terminal Block (support remote switch, Barrel Jack covered when not in use.)	Barrel Jack with optional 4-pin Terminal Block (support remote switch, Barrel Jack covered when not in use.)
Power Protections	TVS for power input protection Moderate disturbance protection with a TVS LC filter. Alternate DC supplies should be IT equipment rated when possible.	TVS for power input protection Moderate disturbance protection with a TVS LC filter. Alternate DC supplies should be IT equipment rated when possible.
BIOS	Insyde	Insyde
Operating Systems	Windows 10 IoT Enterprise, Ubuntu 20.04 IOTG	Windows 10 IoT Enterprise, Ubuntu 20.04 IOTG
Special Features	Watchdog timer RTC PTT in BIOS, TPM header, Nuvoton NPCT750AABYX Hardware Autopower on	Watchdog timer RTC PTT in BIOS, TPM header, Nuvoton NPCT750AABYX Hardware Autopower on
Mounting Options	DIN (edge mount) Wall VESA Desk	DIN (edge mount) Wall VESA Desk
Thermal Standards, Subject to Change through RFI and RFQ steps	System Operating Temperature: 0-50C Board Operating Temperature: 0-65C Storage Temperature: -10-85C Operating Humidity: 0% - 90%	System Operating Temperature: 0-50C Board Operating Temperature: 0-65C Storage Temperature: -10-85C Operating Humidity: 0% - 90%
Radio Specifications when equipped with INT-9260 Wifi/BT (device for indoor use)		
Frequency Bands	2.4GHz and 5GHz bands	
Operating Frequency	2400 - 2485 MHz 5150 - 5250 MHz, 5250 - 5350 MHz 5470 - 5725 MHz, 5725 - 5878 MHz	
Channel spacing / Bandwidth	2.4GHz: 802.11b/g/n; 5 MHz / BT: 1MHz Bandwidth: 20 MHz / 40 MHz 5 GHz: 802.11a/n/ac: 20, 40, 80, 160 MHz	
RF output power	20dBm (2400-2485 MHz) IEEE 802.11b/g/n& BT 10dBm (2400-2485 MHz) BLE 23dBm (5150-5725 MHz) IEEE 802.11a/n/ac 13.98 dBm (5725-5875MHz) IEEE 802.11a/n/ac	

Type of Modulation	2.4GHz: DSSS/OFDM/FHSS 5 GHz: OFDM
Antenna Specifications	ANT200 - PIFA type with 2dBi/2dBi gain on 2.4 & 5 GHz
Modes of operation	Duplex (Tx/Rx)
Duty cycle (access protocol)	As In: IEEE 802.11 a/b/g/n/ac
Version of firmware /software	Software Intel PROSet/Wireless WiFi Software 20..x and following versions for WIFI/BT

* Limited RS422/485 capability. See appendix H for details.

1.4 - Exterior Features and Dimensions

1.4.1 - Front I/O

The HX310 is pictured. See [Section 2.1](#) for information on the HX330

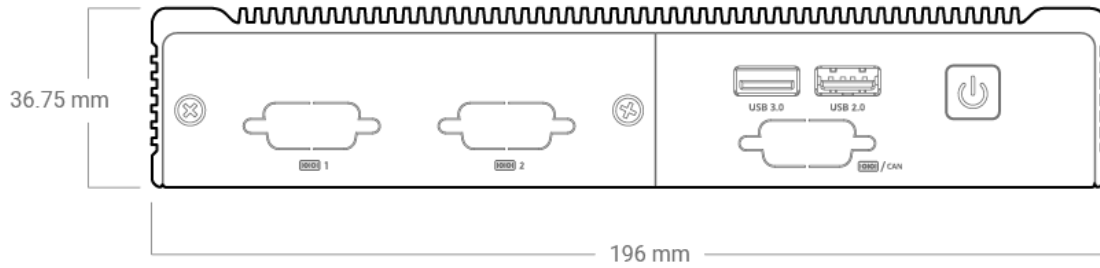

1.4.2 - Back I/O

The HX310 is pictured with the dual LAN option.

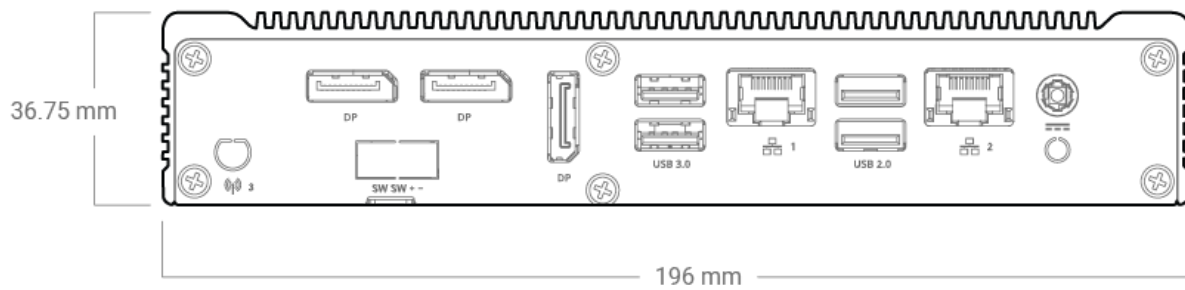

1.4.3 - Helix 300 Dimensions (HX310 / HX330)

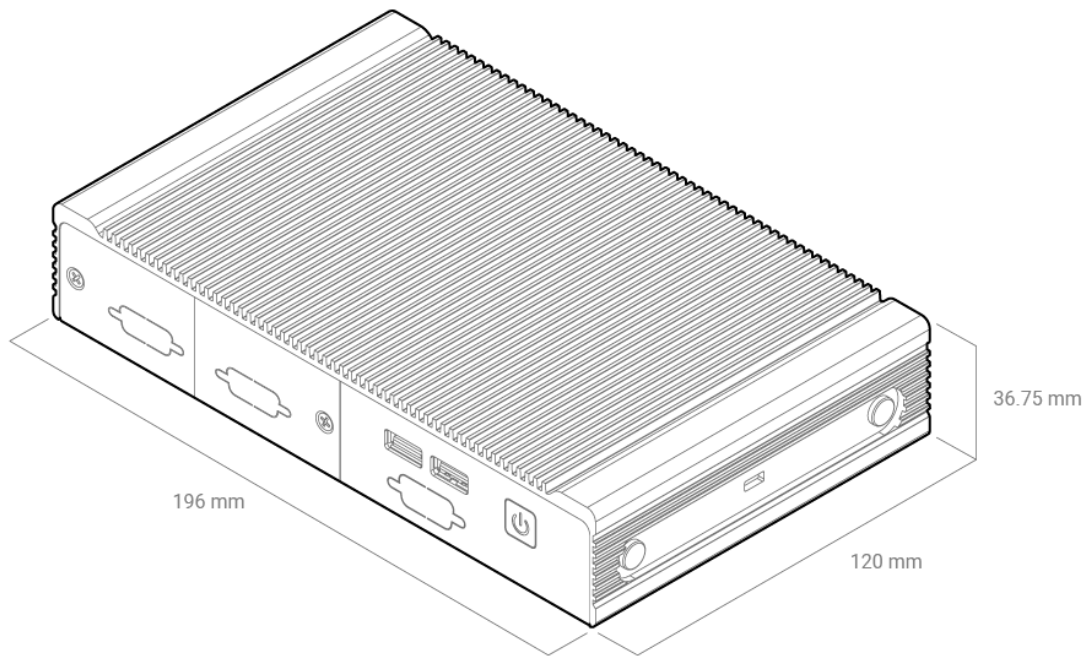

1.5 - System Block Diagram

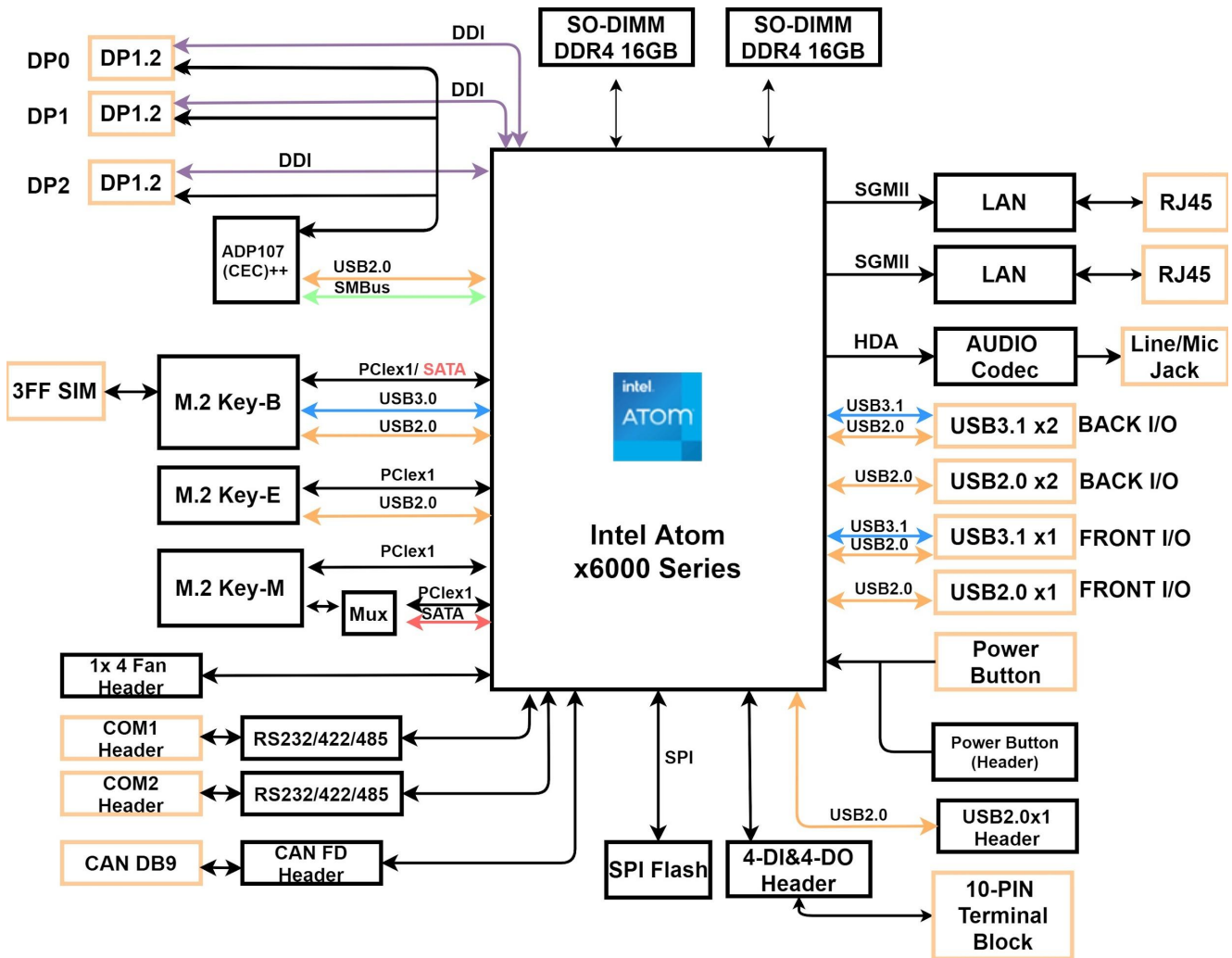

2 - I/O Definitions

2.1 - Front I/O Definition

The HX310 with the COM option is pictured.

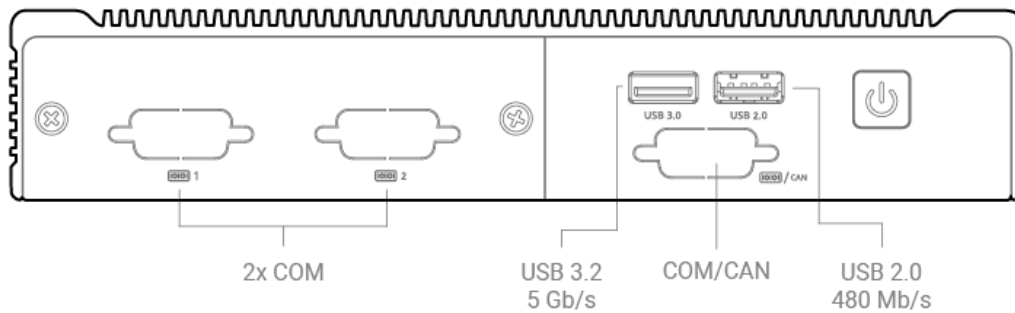

The HX310 with the Antenna option is pictured.

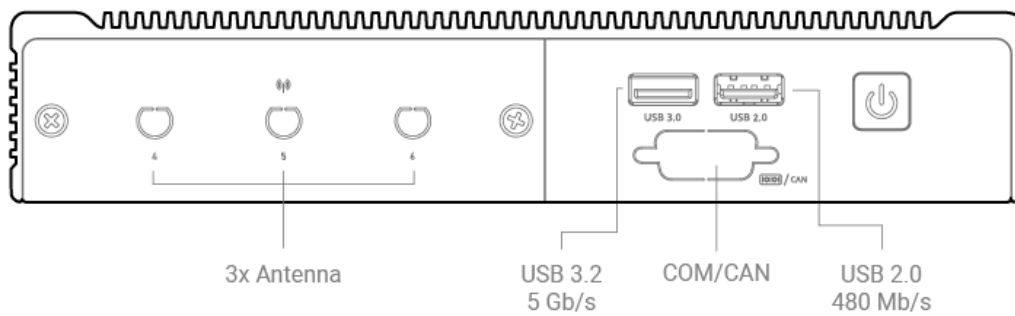

The HX310 with the DIO option is pictured.

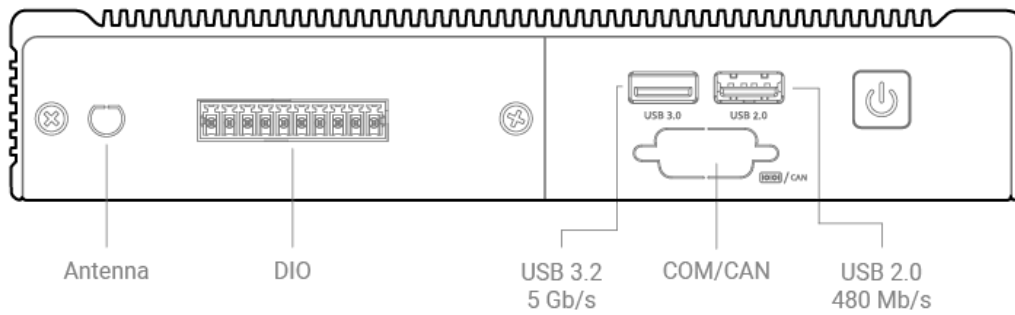

The HX330 with the additional dual LAN option is pictured.

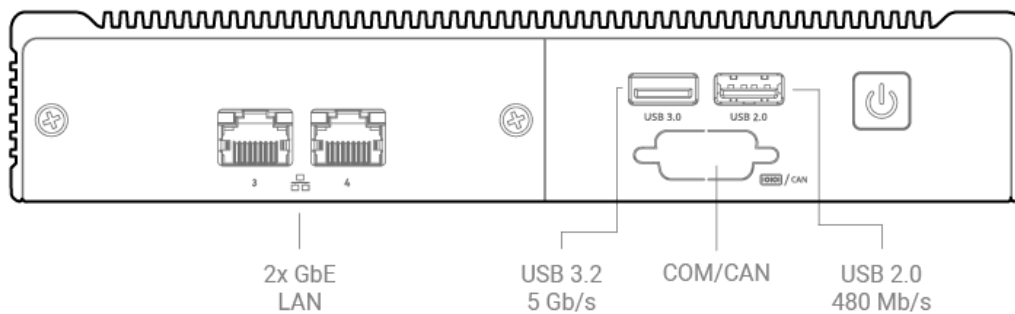

Power Button / Power LED

The front power button can be used to turn on and off the Helix system. The power button is a momentary contact button with a blue LED backlight used to display the status of the system. A single press while the system is on will initiate a graceful shutdown operation from the OS. Pressing and holding the button for 4 seconds while the system is running will cause a hard reset of the system. The system can be woken by a single press of the power button from any state.

The LED backlight will indicate the system status. A solid blue light indicates that the system is powered in the S0 state. A flashing blue light indicates the system is in the sleep state. The LED is off in S5 and deep sleep states.

SIM Card

A 3FF Subscriber Identity Module (SIM) card slot is present on the front panel of the Helix platform allowing native support for OnLogic cellular modules. The SIM signals are connected to the M.2 B-Key internal expansion slot. In order to access the SIM Slot, the Modbay panel and bottom plate

must first be removed. The Modbay panel is secured by two screws on either side, pictured above in the “Front I/O Definition” section.

The SIM slot is a Push-Push type receptacle. To insert or remove the SIM card from the front panel of the Helix platform, please use a small implement to push the card into the slot until it clicks. To remove the card, push with a small implement until the card clicks, then pull on the free end of the card to remove it.

COM DB9 Option

The serial port mode on Helix can be selected in the BIOS configuration. The serial ports support RS-232, RS-422, and RS-485 configurations. Refer to the BIOS manual in Appendix C for configuration instructions.

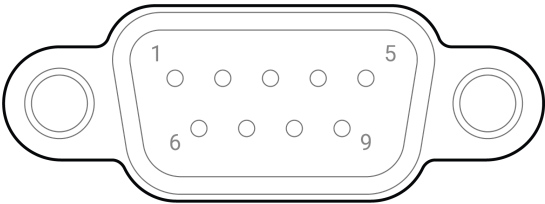
	Pin	RS-232	RS-422	RS-485
	1	NC	TX-	TX-/RX-
	2	RX	TX+	TX+/RX+
	3	TX	RX+	NC
	4	NC	RX-	NC
	5	GND	NC	NC
	6	NC	NC	NC
	7	RTS	NC	NC
	8	CTS	NC	NC
9	NC	NC	NC	

COM DB9 pinout

CAN DB9 option

The CAN port on Helix supports CAN2.0 A/B at baud rates from 100-1000 kbaud. The system CAN port is not internally terminated, and a properly terminated (*120 Ohms, typical*) cable should be used. CAN messages may be sent and received through the sideband Programmable Services Engine, via the Host Embedded Controller Interface (HECI). Windows drivers are available for this interface, and a command line tool is available for download from our [support website](#).

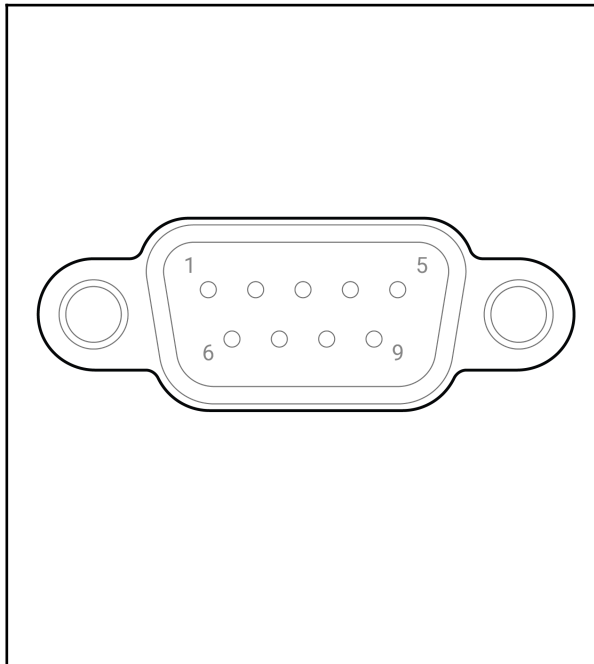

Pin	Signal
1	NC
2	CAN_L
3	GND
4	NC
5	NC
6	GND
7	CAN_H
8	NC
9	NC

COM DB9 pinout

USB 3.2

There is one USB 3.2 Gen 2 port on the front panel of the Helix platform. This port is capable of linking at 10Gb/s transfer rates.

USB 2.0

There is one USB 2.0 port on the front panel of the Helix platform. This port is capable of linking at 480 Mb/s transfer rates.

DIO option

The Helix platform supports an optional Isolated Digital I/O add-in card through a 10-pin terminal block (Mating connector: Phoenix Contact pn: #1840447 or similar). This option allows for integration of the Helix platform with existing PLC integrations or other digital logic applications. The Digital IO may be managed through the sideband Programmable Services Engine, via the Host Embedded Controller Interface (HECI). Windows drivers are available for this interface, and a command line tool is available for download from our support website. For a complete explanation of features, operating voltages, and safety information, please refer to the DIO expansion manual on the OnLogic support site.

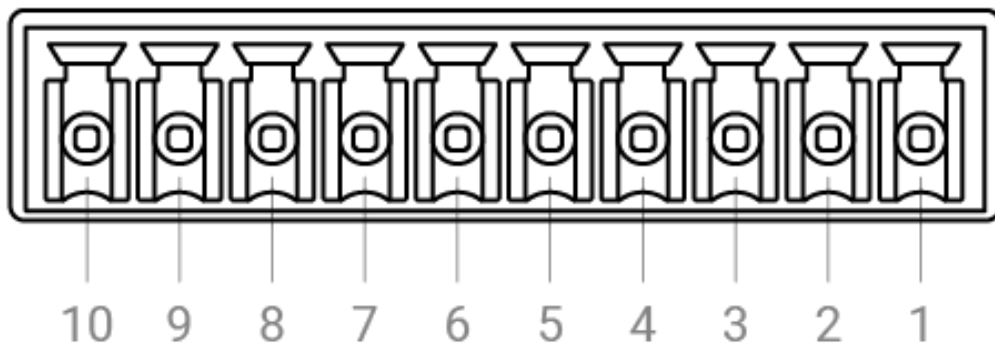

Pin 10	Pin 9	Pin 8	Pin 7	Pin 6	Pin 5	Pin 4	Pin 3	Pin 2	Pin 1
GND	In 4	In 3	In 2	In 1	Out 4	Out 3	Out 2	Out 1	Power

Helix DIO Support Site

<https://www.onlogic.com/support/documentation/hx300-technical-resources>

Dual LAN option

The HX330 supports up to two additional LAN ports on the front Modbay slot of the system. Both ports are Intel I210 network controllers.

2.2 - Rear I/O definition

The rear I/O of the HX310 is shown below. The HX330 has the same connector orientations and locations on the motherboard.

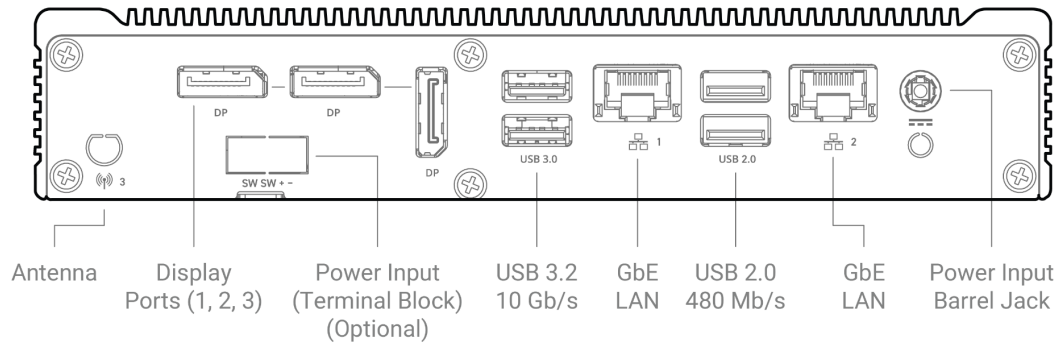

Barrel Jack Power Connector

Mainboard power is applied to the Helix platform by way of a female barrel jack connector (OD: 5.5mm ID: 2.5mm. 12mm length). The system is operational from 9V~24V at 5 amps, 12V only operation is at 3A. The maximum rated current of the connector is 7A. Use a wire gauge that is rated for the operational current. See below for on-board connector pinout.



Center Positive

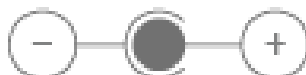

Barrel Jack power pinout

DisplayPort 1, 2, & 3

Helix utilizes Intel's Integrated Gen 11 processor graphics that power the onboard DisplayPorts. This means resolutions up to 4096x2160 @ 60Hz are supported on all three outputs simultaneously. All ports support Multi-Stream Transport (MST).

LAN1 - MaxLinear GPY115 PHY

Helix supports up to 1Gbps link speeds over standard shielded CAT5e or CAT6 cables. This is done using the Integrated MAC and the MaxLinear GPY115 PHY. The connector is the industry standard RJ45 connector. The LAN link state and activity is shown by the two LEDs enclosed in the port. The description is included below.

LAN2 - MaxLinear GPY115 PHY

The second LAN Port on Helix supports up to 1Gbps link speeds over standard shielded CAT5e or CAT6 cables. The connector is the industry standard RJ45 connector. The LAN link state and activity is shown by the two LEDs enclosed in the port. The description is included below. The second LAN port is available only with the Pentium J6426 CPU option.

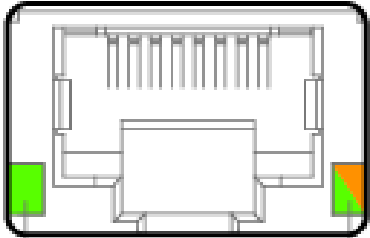
	LED	State	Function
	LED1	Blinking Green	1Gb/s activity
	LED2	Blinking Orange	100 Mb/s activity
		Blinking Green	10 Mb/s activity

LAN activity light description

USB 3.2

The dual stack USB 3.2 ports on the rear panel are USB 3.2 Gen 2 ports, capable of linking at 10Gb/s transfer rates.

Terminal block power option

If the terminal block power option is selected, mainboard power is applied to the Helix platform through a 4-pin terminal block connector (Mating part: Phoenix Contact #1840382 or equivalent).

The system is operational from 9V~24V at 5 amps, 12V operation is at 3A. The maximum rated current of the connector is 6A per pin. Use a wire gauge that is rated for the operational current. Cables should be properly terminated with wire ferrules. Do not use the terminal block with tinned wire ends or solid core wire. Always follow the part number tightening torque and wire sizing specifications to prevent damage to connector systems and PC. See below for connector pinout.

When using the remote switch connections with the terminal block option, mating power switch cables should be a twisted-pair wire with floating shield to assure proper immunity to EMI/RFI. It is recommended to keep wires at less than 3 meters in length. Switches should be momentary contact type only.

Pin	Function
1	DC -
2	DC +
3	SW1
4	SW2

Terminal block power pinout

2.3 - Motherboard Connectors

The motherboard is the same for HX310 and HX330. The second LAN port is only available for configurations with the Pentium J6426 CPU option.

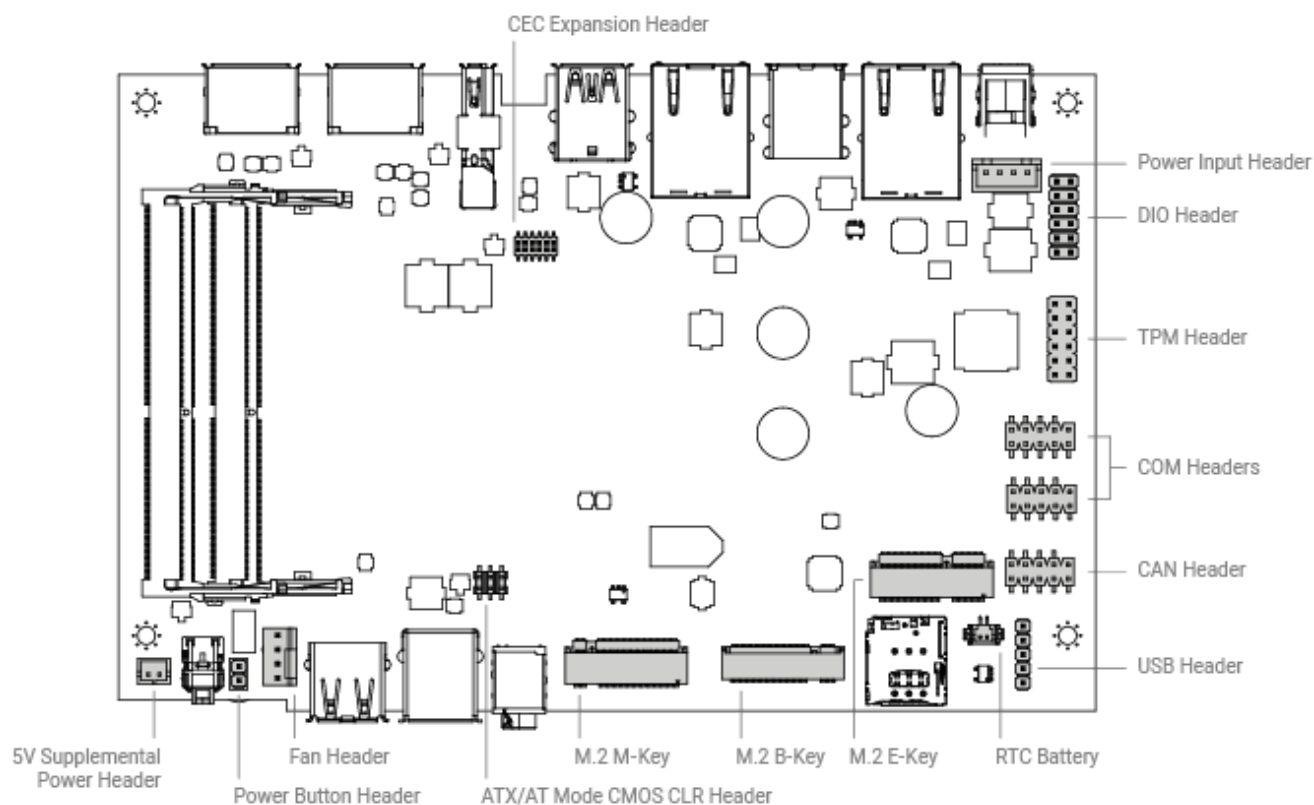

M.2 B-Key

An M.2 B-Key port is present on the Helix motherboard to allow support for B-Key form-factor expansion cards. Supported cards include 3042, 2242, 2260, 2280 form-factors. The B-Key connector on the Helix platform supports PCIe Gen 3 x1, USB 3.2 5Gb/s, USB 2.0, SATA Gen I (1.5Gbps), SATA Gen II (3.0Gbps), and SATA Gen III (6.0Gbps) devices.

The 3FF Micro SIM card slot is available for OnLogic 4G Extrovert modules.

A full pinout table for this expansion slot is provided in **Appendix E**.

M.2 E-Key

An M.2 E-Key port is present on the Helix motherboard to allow support for E-Key form-factor wireless expansion cards. Only 2230 form-factor cards are supported. The E-Key connector on the Helix platform supports PCIe Gen 3 x1 and USB 2.0.

A full pinout table for this expansion slot is provided in **Appendix E**.

M.2 M-Key

An M.2 M-Key port is present on the Helix motherboard to allow support for M-Key form-factor expansion cards. Only 2280 form-factor cards are supported. The M-Key connector on the Helix platform includes support for PCIe Gen 3 x2, SATA Gen I (1.5Gbps), SATA Gen II (3.0Gbps), and SATA Gen III (6.0Gbps) devices.

A full pinout table for this expansion slot is provided in **Appendix E**

SO-DIMM1 & SO-DIMM2

The Helix platform has two onboard DDR4 SO-DIMM Slots. Below find the specifications of the two SO-DIMM Slots:

- Maximum Capacity: DDR4-3200 32GB with two 16GB SO-DIMM Modules
- Channel configuration: 1DIMM Per Channel (DPC) - 2 Channels
- No ECC Support

COM1 & COM2

The two on-board COM headers utilize standard 9-pin 2.54mm pitch male pin headers with the pin configuration in the chart below. These serial ports support RS-232, RS-422 Full-Duplex, and RS-485 half-Duplex configurations. The serial port communication mode can be selected in the BIOS configuration. Refer to the BIOS manual (**Appendix C**) for configuration instructions.

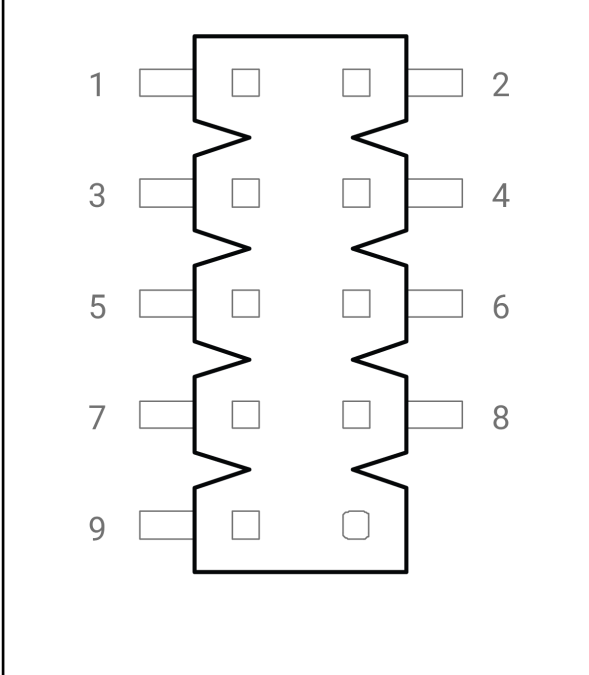
	Pin	RS-232	RS-422	RS-485
	1	NC	TX-	TX-/RX-
	2	RX	TX+	TX+/RX+
	3	TX	RX+	NC
	4	NC	RX-	NC
	5	GND	NC	NC
	6	NC	NC	NC
	7	RTS	NC	NC
	8	CTS	NC	NC
	9	NC	NC/PWR	NC/PWR
	10	(KEY)	(KEY)	(KEY)

Motherboard Serial header pinout

CAN

The on-board CAN transceiver headers utilize standard 9-pin 2.54mm pitch male pin headers with the pin configuration in the chart below. Refer to the CAN user guide (**Appendix D**) for configuration instructions.

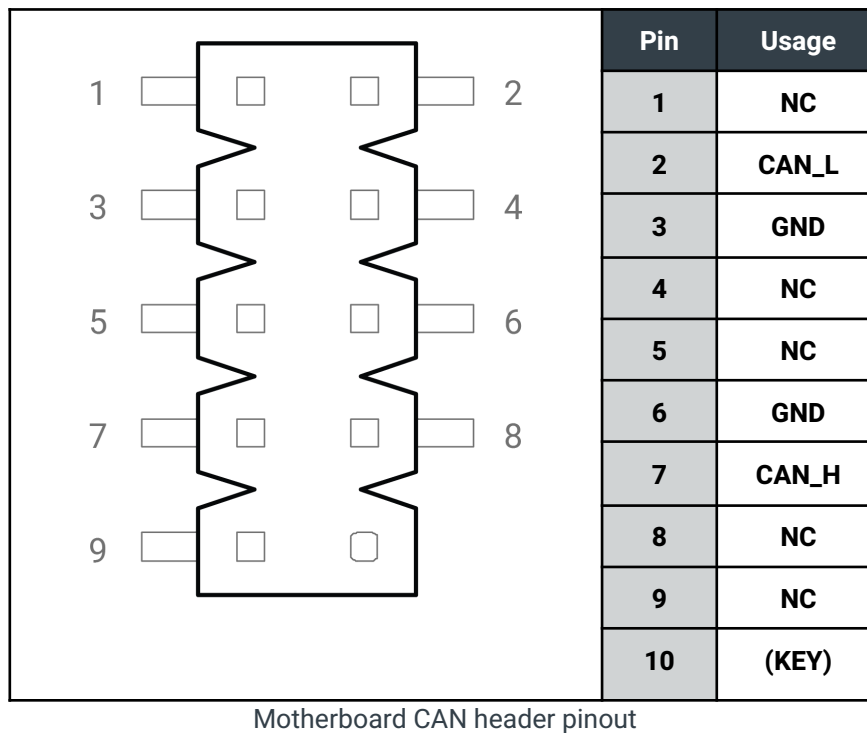

BIOS EEPROM

If the BIOS needs to be updated, please refer to **Appendix C** for reflashing instructions.

Power Switch Header

The on-board power switch header can be used to control the power state of the Helix platform in parallel with the front panel power button. Mating power switch cables should be a twisted-pair wire with floating shield to assure proper immunity to EMI/RFI. Mating connector is a standard 2.54mm female header. It is recommended to keep wires at less than 3 meters in length. Switches must be momentary contact type only.

ATX/CMOS Jumper Header

A 2mm pin header and jumpers are used to clear the CMOS settings and select the hardware auto power-on behavior of the Helix platform.

ATX mode can be selected by moving the pin jumper to connect pins 3 and 5 will select ATX power mode. The system power-on will be controlled by the system power button or other supported wake

events. When the pin jumper is moved to connect pins 1 and 3, the system will operate in AT mode, where the system will power on when system power is first applied. The default selection is ATX mode.

The system CMOS settings can be cleared with the second pin jumper. To clear the CMOS the following steps shall be followed:

1. Disconnect system power.
2. Place jumper in the “clear” position.
3. Wait 10 seconds.
4. Remove jumper from the “clear” position and return to default position

	Jumper Position	Function
	1-3	AT mode
	3-5	ATX Mode (Default)
	2-4	Clear CMOS
	4-6	No Function (Default)

ATX/CMOS header pinout

RTC battery header

The RTC battery on the Helix platform is used to retain BIOS CMOS settings and maintain the real-time clock for the system. If the RTC battery is low, CMOS settings will not be retained and you may receive an alert in the operating system. The cabled RTC battery should be replaced with a Maxell CR2032-WK11 (or UL listed equivalent). An equivalent battery shall use a Hirose DF13-2S-1.25c connector to mate with the on-board connector.

TPM header

Helix features an onboard TPM (Trusted Platform Module) header. Helix supports OnLogic’s module (OnLogic part TPM01) featuring TPM 2.0. This gives the option to have a dedicated secure module to secure Helix through cryptographic keys.

Fan Header

The on-board fan header can power and control any five volt three or four-wire fan (including variable-speed PWM fans) using the standard pin configuration in the chart below. Three-wire fans will only connect to pins 1-3. This header utilizes a standard 4-pin 2.54mm pitch fan connector with a small retention tab. Any mating connector with the standard form factor, such as Molex part number 0470541000, can be used to connect a fan. Most CPU and case fans utilize this connector and pinout. The 5V pin on this connector can provide up to 1A of current.

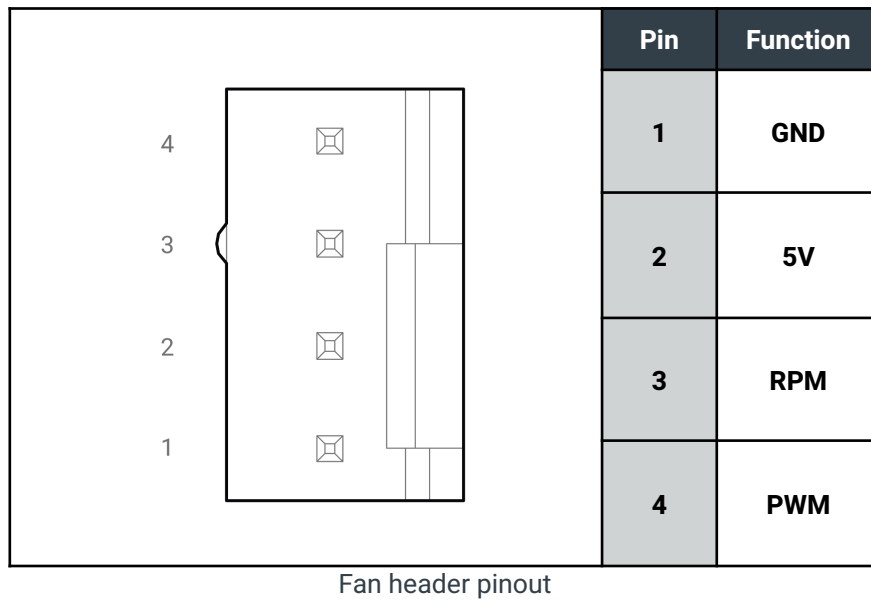

USB 2.0 Header

The on-board USB 2.0 header provides a single USB 2.0 signal. It utilizes a standard 4-pin 2.54mm pitch male pin connector with the pin configuration in the chart below. The 5V power pin (Pin 1) can provide up to 1A of current.

Pin	Function
1	5V
2	D0-
3	D0+
4	GND
5	Key

USB 2.0 header pinout

Power Input Header

Mainboard power can be applied to the Helix platform by way of the 4-pin JST XH-4 connector (Mating part: JST XHP-4 or equivalent). The system is operational from 8V~24V. The maximum rated current of the connector is 3A per pin. Use a wire gauge that is rated for the operational current. See below for connector pinout.

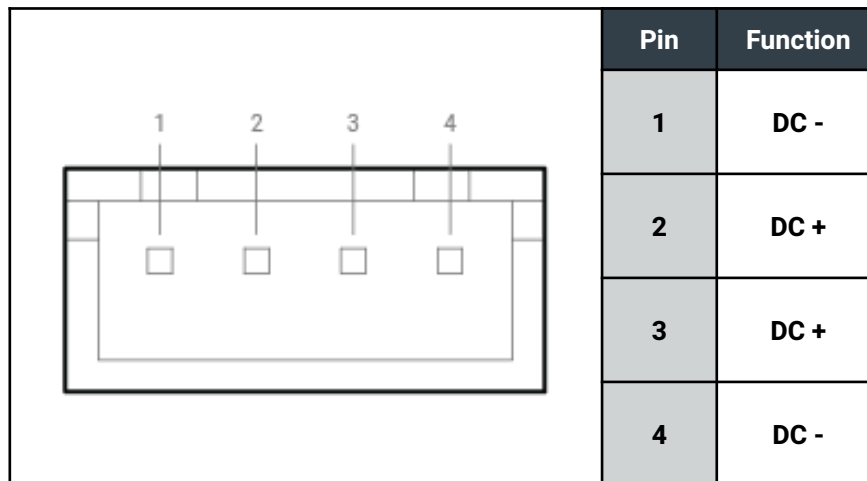

Motherboard power input pinout

Supplemental 5V power output

Additional 5V power can be supplied (to internal devices only) by use of the 2-pin header on the motherboard. The maximum rated current of the connector is 2A per pin. Use a wire gauge that is rated for the operational current. See below for connector pinout.

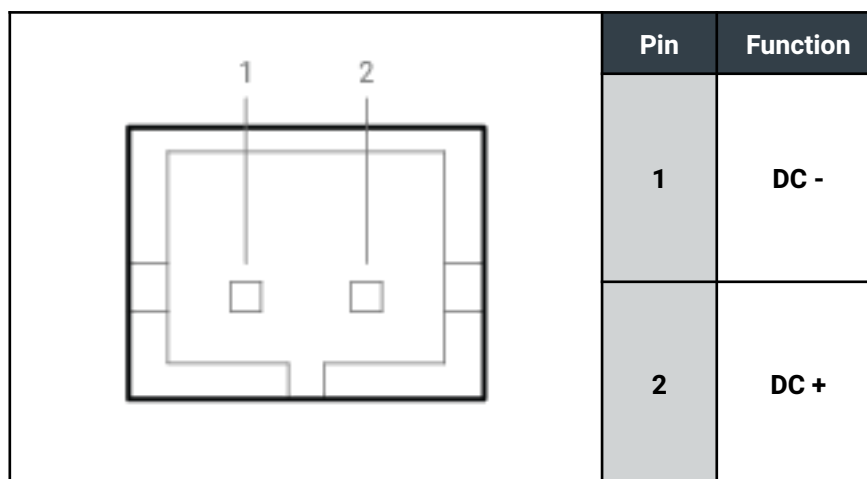

Motherboard power input pinout

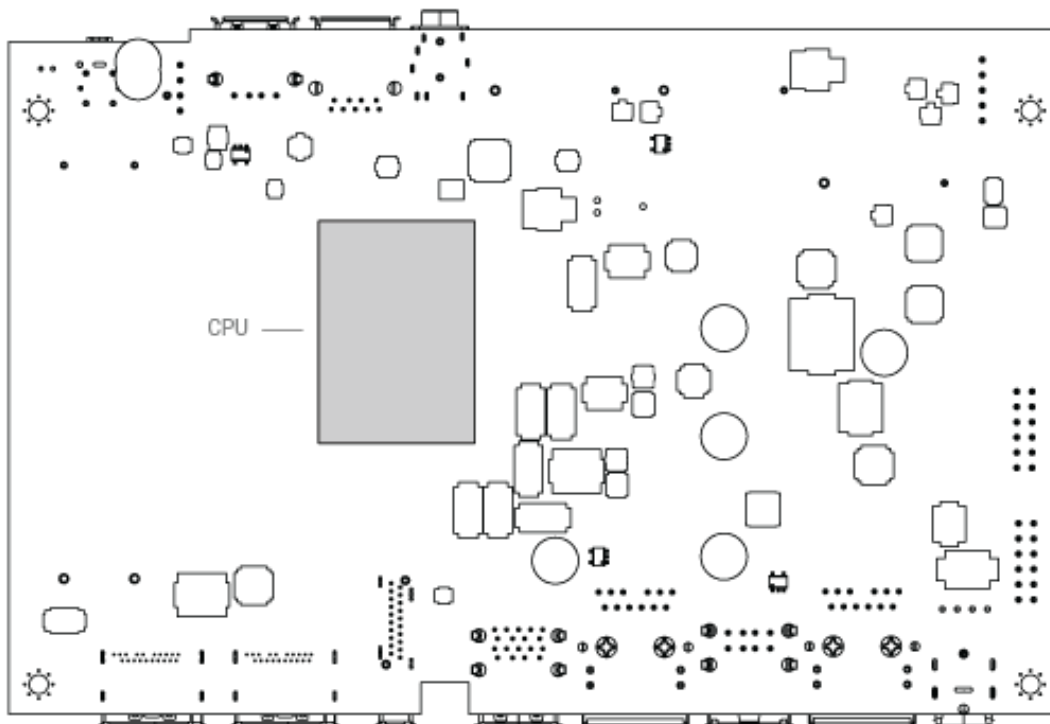

Motherboard bottom view (Heatsink side)

CPU

1. Two CPU options are available for the HX310 and HX330. Both systems can be configured with either a 2-core Celeron N6211, or a 4-core Pentium J6426. The second on-board LAN port is available standard with the 4-core Pentium J6426 option.

3 - Mounting Instructions

3.1 - Wall Mount & DIN Rail Mounting

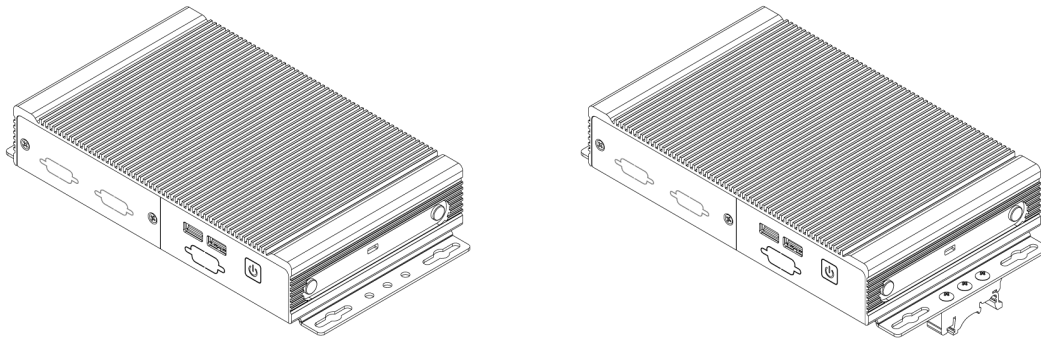

Step 1: Attach wall mounting brackets MTW101 (no DIN), MTW101-K (DIN), MTW107 (Vertical DIN), VM1041 (VESA) to the chassis using the supplied screws. Specifications can be found below:

Screw type: M3X0.5 FH 120 Degree Screw

Length: 4 mm

Step 2: Locate the 4 holes that line up accordingly to the bracket as shown below.

Step 3: Fasten system to surface. The mounting bracket systems are required to secure 3x the hanging weight of the computer system. The mating substrate must be capable of maintaining the same rating.

Step 4 (for DIN Bracket): Using the outer 2 holes of the 3 hole set on the wall mount bracket, line up the DIN bracket.

Step 5 (for DIN Bracket): Using the supplied screws, using a Phillips head screwdriver, mount the DIN bracket to the bracket.

Step 6 (for DIN Bracket): Mount system onto the DIN rail.

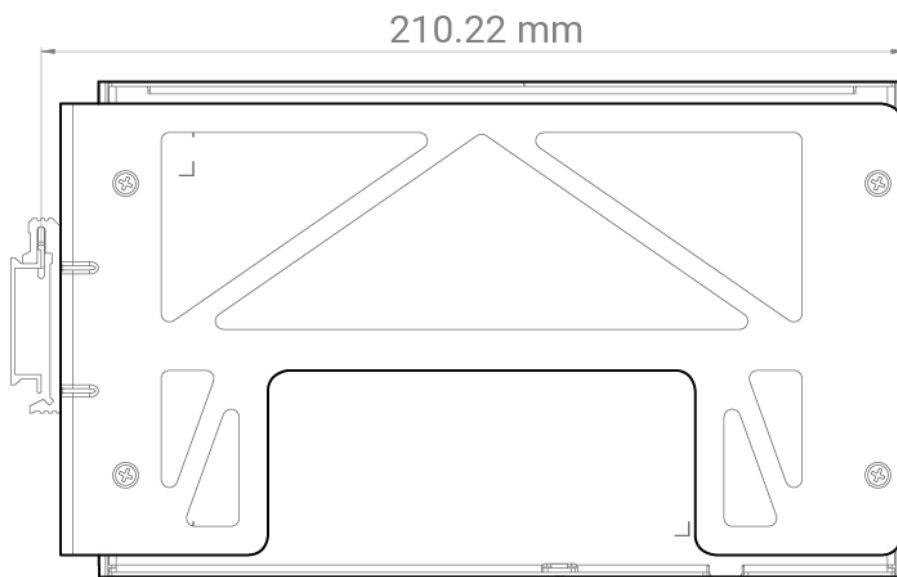
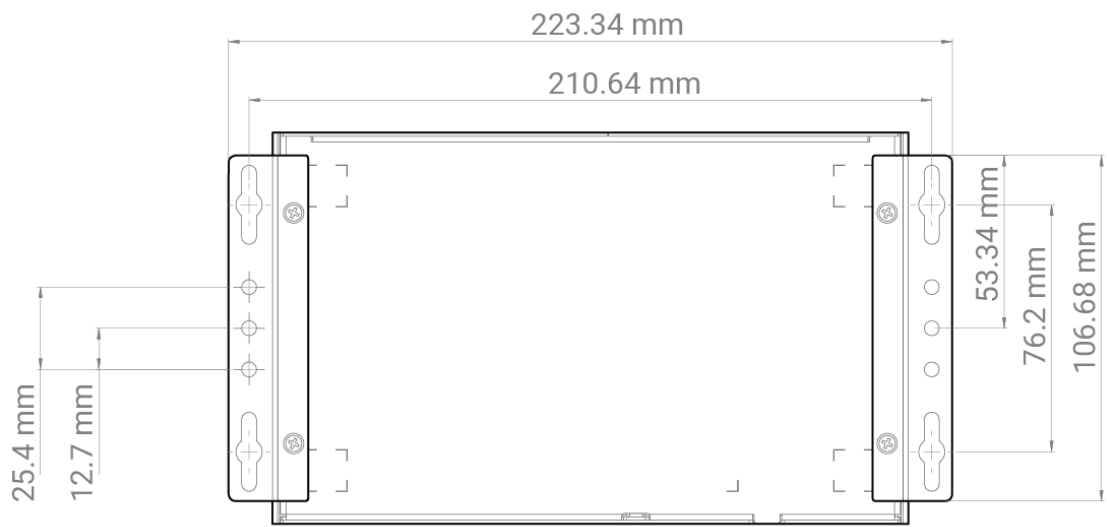

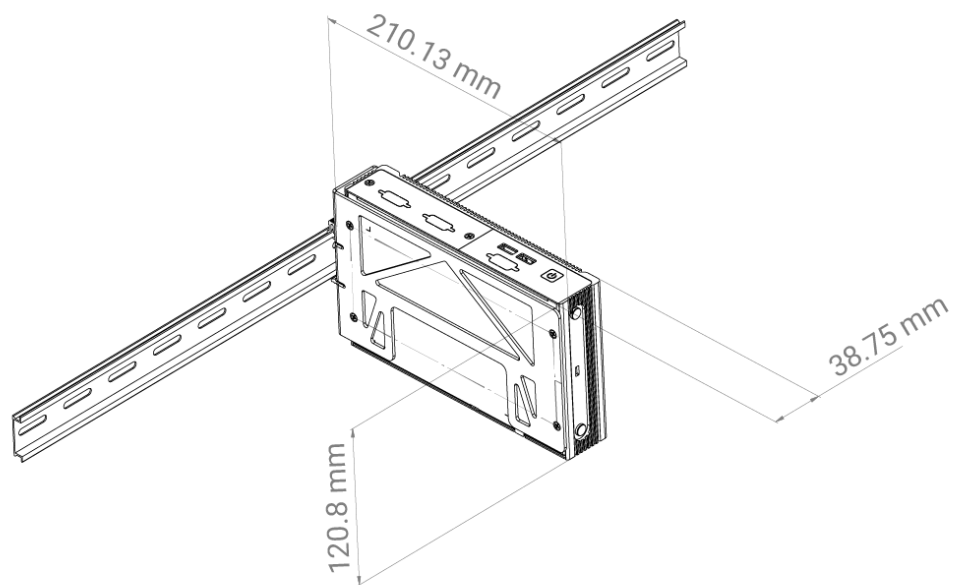

3.1 - VESA Mounting

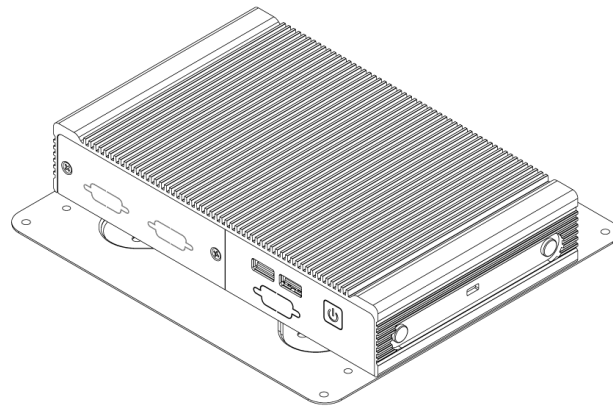

Step 1: Attach wall mounting brackets to the chassis using:

Screw type: M3X0.5 FH 120 Degree Screw

Length: 4 mm

Step 2: Locate the 4 holes that line up accordingly to the bracket as shown

Step 3: Fasten system to surface. The mounting bracket systems are required to secure 3x the hanging weight of the computer system. The mating substrate must be capable of maintaining the same rating.

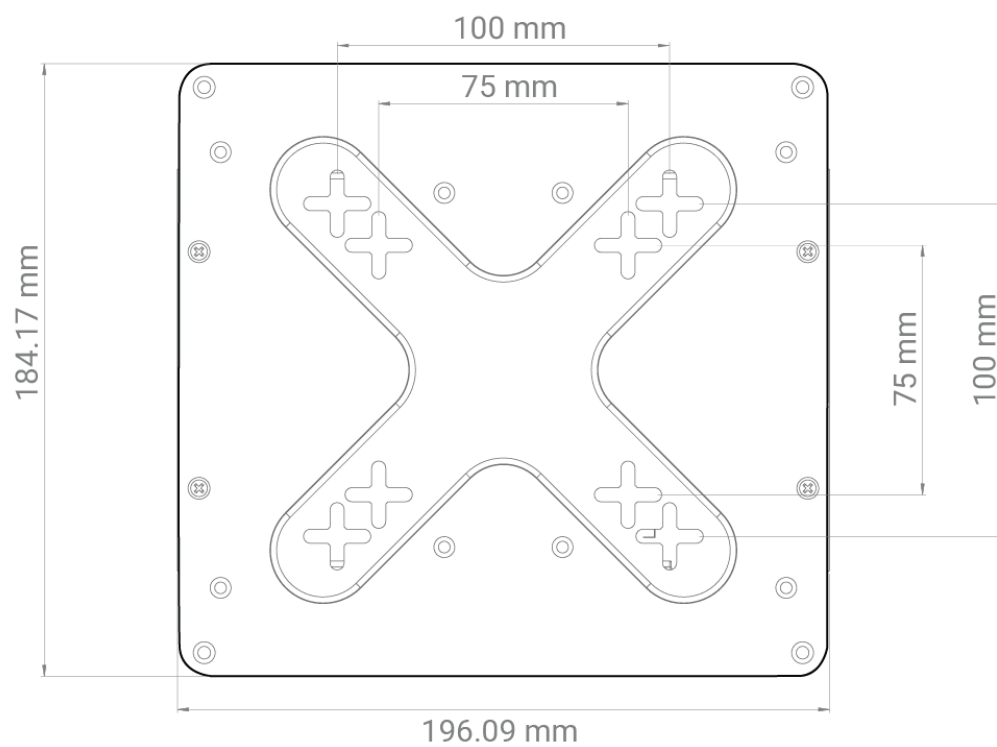

4 - Power Management

4.1 - Wake-Up Events

The Helix platform supports multiple power states. The wake-up events can be configured in the BIOS. This section describes the supported power management functions and gives information on protection circuitry for power adapters. Low power shutdown is an additional option in the BIOS. See **Appendix C** for more information.

Wake-Up Event	From ACPI State	Comments
Power Button	Low Power shutdown, S5, S3	
LAN	S5, S3	Must be enabled in BIOS
USB	S3	
RTC Wake set by BIOS	S5, S3	Must be enabled in BIOS
RTC Wake set by OS	S3	

4.2 - Protection Circuitry

Parameter	Value
Nominal operating voltage (Rated DC value of input)	8~24V
Undervoltage protection trip DC level (system turns off)	6.5V
Maximum safe DC voltage (system not damaged)	27V

These DC levels specified are the absolute max values for the pins for function and safety of the system. The protection circuitry allows for brief transient voltages above these levels without the system turning off or being damaged. A transient voltage suppressor on the power input allows momentary excursions above stated limits. For input power consumption and current see **Appendix A**.

5 - Regulatory Compliance

CE

This device has been tested to the relevant EMC and Safety standards. Modifications by the user may invalidate certifications. Testing included EN 55032, EN 55035, EN 60601-1, EN 62368-1, and IEC 60945 Ed. 4.

FCC Statement

This device complies with part 15 of the FCC rules as a Class A device. Operation is subject to the following two conditions: (1) this device may not cause harmful interference and (2) this device must accept any interference received, including interference that may cause undesired operation.

ISED (Innovation, Science and Economic Development Canada)

This device complies with Industry Canada license-exempt RSS standard(s). Operation is subject to the following two conditions: (1) this device may not cause interference, and (2) this device must accept any interference, including interference that may cause undesired operation of the device.

Le présent appareil est conforme aux CNR d'Industrie Canada applicables aux appareils radio exempts de licence. L'exploitation est autorisée aux deux conditions suivantes : (1) l'appareil ne doit pas produire de brouillage, et (2) l'utilisateur de l'appareil doit accepter tout brouillage radioélectrique subi, même si le brouillage est susceptible d'en compromettre le fonctionnement.

CAN ICES-003(A) / NMB-003(A)

UKCA

The computer system was evaluated for medical, IT equipment, automotive, maritime and railway EMC standards as a class A device. The computer complies with the relevant IT equipment directives for the UKCA mark.

VCCI

This is a Class A product based on the standard of the Voluntary Control Council for Interference (VCCI). If this equipment is used in a domestic environment, radio interference may occur, in which case the user may be required to take corrective actions.

この装置は、クラス A 情報技術装置です。この装置を家庭環境で使用すると電波妨害を引き起こすことがあります。この場合には使用者が適切な対策を講ずるよう要求されることがあります。

VCCI-A

6. - Appendices

6.1 - Appendix A: Power consumption

The power consumption of the HX310 system was measured for various system configurations, workloads, and power states at both 12V and 24V system input voltages. Tests were performed using Burnintest v9.0 build 1012 to stress system components with and without graphics enabled. The build configurations and power consumption are listed in the tables below.

*The configurations below are using representative samples of internal devices, the specific components mentioned below may vary from the devices provided by OnLogic. The power consumption for each system configuration is record below

System Component	Config 1 Low HX310	Config 2 Mid HX310	Config 3 High HX330
CPU	Celeon N6211 6W, 2 Cores	Pentium J6426 - 10 W, 4 Cores	Pentium J6426 - 10 W, 4 Cores
Memory	8GB DDR4 So-DIMM 1x M4S0-8GS1NCIK Innodisk	16GB DDR4 So-DIMM 1x M4S0-AGS1OCIK Innodisk	32GB DDR4 So-DIMM 2x M4S0-AGS1OCIK Innodisk
LAN	1x GPY115	2x GPY115	2x GPY115
Storage #1 M.2 M-Key	128Gb SATA	1TB NVMe	1TB NVMe
M.2 B-Key		1TB NVMe	Innodisk EGPL-201-W2 dual LAN
M.2 E key		Intel 9260	Intel 9260
COM1	Loopback test	Loopback test	Loopback test
COM2	Loopback test	Loopback test	N/A
USB	loopback test (all ports)	loopback test (all ports)	loopback test (all ports)
OS	Windows 10 Pro 64 Bit	Windows 10 Pro 64 Bit	Windows 10 Pro 64 Bit
BIOS Version	A048	A048	A048

Config 1 Low HX310		
Power Consumption	8V (avg W)	24V (avg W)
Windows Idle	6.4	6.7
CPU / system Stress	10.6	11.2
CPU / System & Graphics Stress	13.5	13.8
S3	2.82	2.95
S5	0.80	0.86
Deep S5	0.05	0.17

Config 2 Mid HX310		
Power Consumption	8V (avg W)	24V (avg W)
Windows Idle	10.3	10.7
CPU / system Stress	21.6	22.3
CPU / System & Graphics Stress	25.0	25.6
S3	3.55	3.70
S5	0.75	0.81
Deep S5	0.05	0.17

Config 3 High HX330		
Power Consumption	8V (avg W)	24V (avg W)
Windows Idle	11.0	11.7
CPU / system Stress	21.4	21.3
CPU / System & Graphics Stress	23.7	25.2
S3	3.79	3.85
S5	0.81	0.86
Deep S5	0.05	0.17

6.2 - Appendix B: Isolated DIO guide

Additional information for the Isolated DIO can be found on the OnLogic support site. Please refer to the link below for additional information.

<https://www.onlogic.com/support/documentation/hx300-technical-resources>

6.3 - Appendix C: BIOS manual

For a detailed overview of the BIOS screens and individual settings, please refer to the OnLogic support site. Instructions for updating the BIOS can also be found on the support site. Please refer to the link below for detailed instructions.

<https://www.onlogic.com/support/documentation/hx300-technical-resources>

6.4 - Appendix D: CAN user guide

Additional information for using the on-board CAN transceiver can be found on the OnLogic support site. Please refer to the link below for additional information.

<https://www.onlogic.com/support/documentation/hx300-technical-resources>

6.5 - Appendix E: System thermal results

The thermal performance of the Helix platform was validated by fully loading system components while the test system was exposed to the limits of its rated environment (0C-50C). CPU clock speeds and core temperatures were measured for the duration of the test. The results were analyzed by comparing the average clock speed over the duration of the test to the rated base clock speed. A passing result was defined by an average clock speed no less than 20% of the rated base clock and operation below the CPU Max temperature limit.

HX300 -Elkhart Lake SKU 3 1800mhz base clock 50C-0C Thermal Testing Graph - The image below shows the thermal test results from an HX300 in a thermal chamber over the course of 20 hours at a workload of 100%. After 17 Hours the 50C thermal chamber was brought down to 0C.

50C Ambient Performance

Item Tested	Pass	Test Result	Delta [%]
CPU Temp.	<100 C	95 C	5C
Restarted	<1 times	0 Times	100%

Avg. CPU Frequency	>1400 Mhz	1648 MHz	9%
--------------------	-----------	----------	----

0C Ambient Performance

Item Tested	Pass	Test Result	Delta [%]
CPU Temp.	<100 C	49.9 C	50.1C
Restarted	<1 times	0 Times	100%
Avg. CPU Frequency	>1400 Mhz	1596 MHz	11.1%

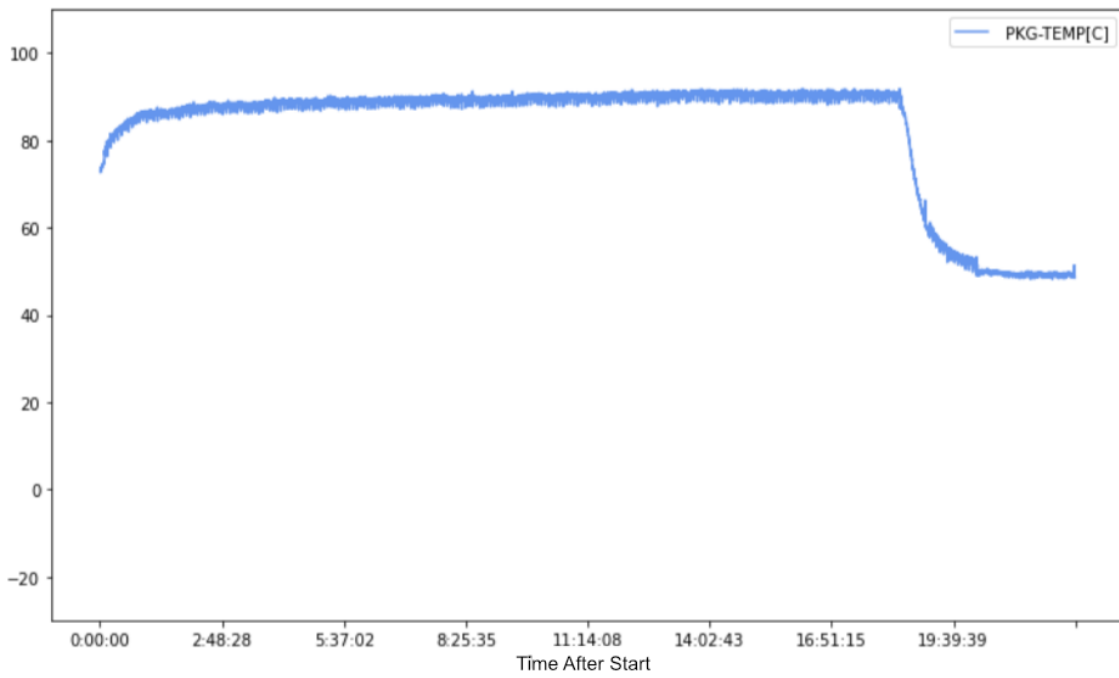

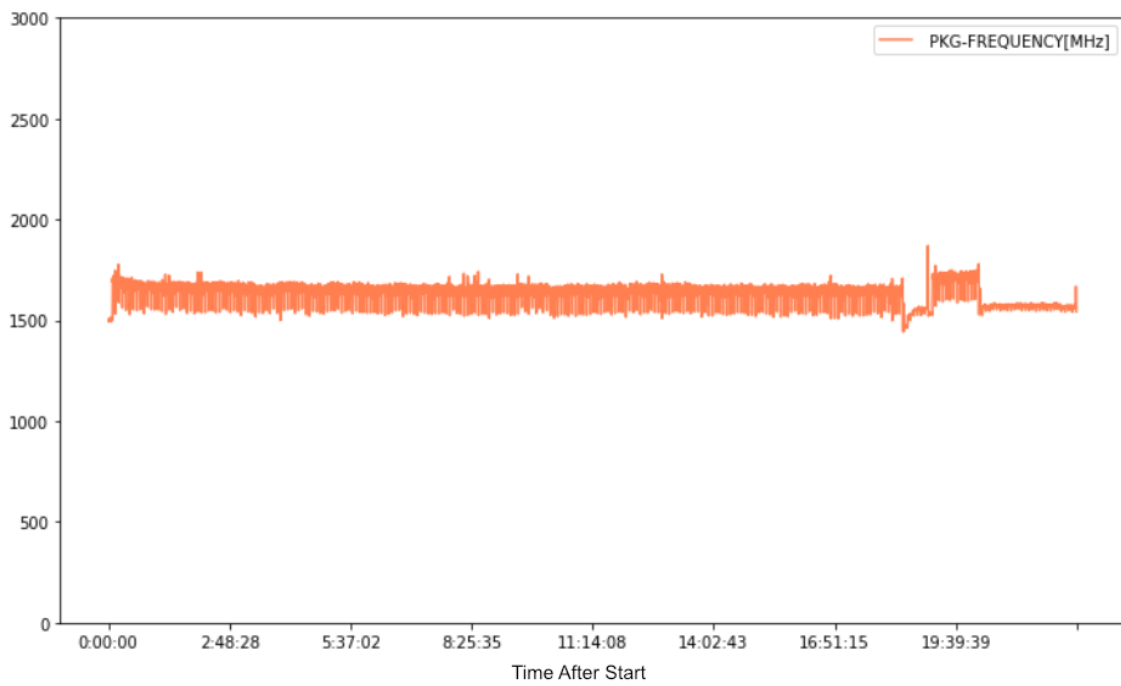
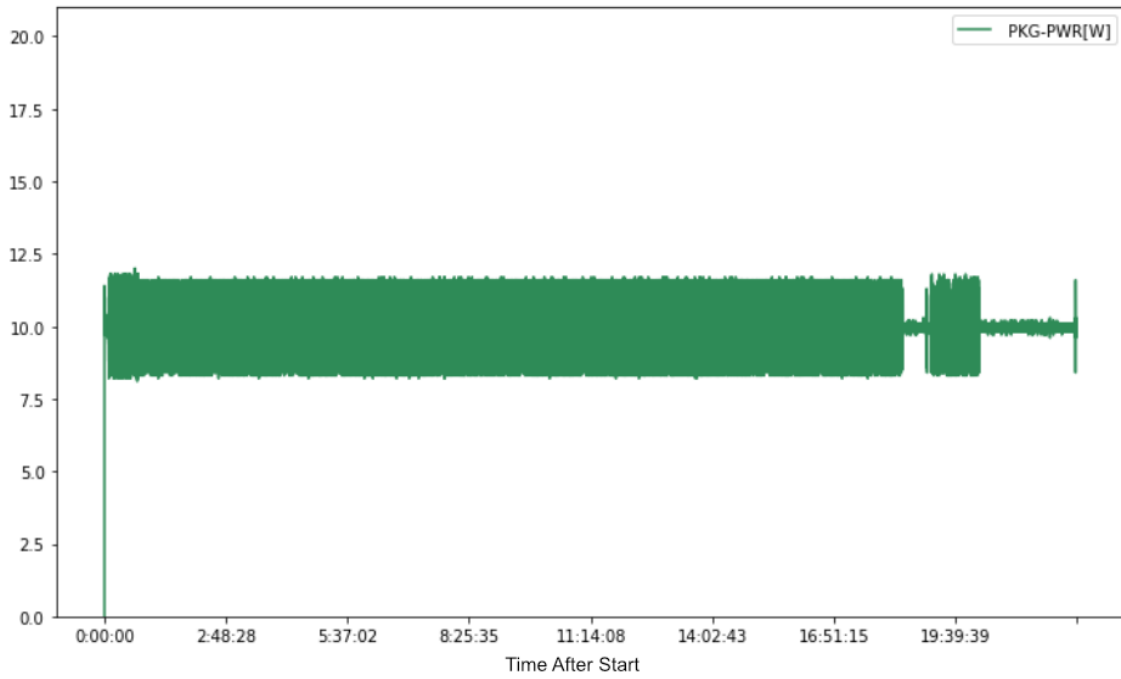

6.6 - Appendix F: Expansion port pinout

6.6.1 - M.2 B-Key

Pin	Function	Function	Pin
1	CONFIG_3	3.3V	2
3	GND	3.3V	4
5	GND	FULL_CARD_POWER_OFF#	6
7	USB 2.0 D+	W_DISABLE1#	8
9	USB 2.0 D-	NC	10
11	GND	KEY	
	KEY	KEY	
	KEY	KEY	
	KEY	KEY	
	KEY	NC	20
21	CONFIG_0	NC	22
23	NC	NC	24
25	NC	GPIO_10/W_DISABLE2#	26
27	GND	NC	28
29	PERn1/USB3.1-Rx-	UIM-RESET	30
31	PERp1/USB3.1-Rx+	UIM_CLK	32
33	GND	UIM_DATA	34
35	PETn1/USB3.1-Tx-	UIM_PWR	36
37	PETp1/USB3.1-Tx+	NC	38
39	GND	NC	40
41	PERn0/SATA-B+	NC	42
43	PERp0/SATA-B-	NC	44
45	GND	NC	46
47	PETn0/SATA-A-	NC	48
49	PETp0/SATA-A+	PERST#	50
51	GND	CLKREQ#	52
53	REFCLKn	PEWAKE#	54
55	REFCLKp	NC	56
57	GND	NC	58
59	NC	NC	60
61	NC	NC	62

63	NC	NC	64
65	NC	SIM_DETECT	66
67	RESET_N	SUSCLK	68
69	CONFIG_1	3.3V	70
71	GND	3.3V	72
73	GND	3.3V	74
75	CONFIG_2		

6.6.2 - M.2 E-Key

Pin	Function	Function	Pin
1	GND	3.3 V	2
3	USB_D+	3.3 V	4
5	USB_D-	NC	6
7	GND	PCM_CLK	8
9	RESERVED	CNV_RF_RESET#_R	10
11	RESERVED	BT_PCMIN	12
13	GND	BT_PCMOUT	14
15	RESERVED	NC	16
17	RESERVED	GND	18
19	GND	NC	20
21	RESERVED	RESERVED	22
23	RESERVED	KEY	
	KEY	KEY	
	KEY	KEY	
	KEY	KEY	
	KEY	RESERVED	32
33	GND	RESERVED	34
35	PETp0	RESERVED	36
37	PETn0	RESERVED	38
39	GND	RESERVED	40
41	PERp0	RESERVED	42
43	PERn0	RESERVED	44
45	GND	RESERVED	46
47	REFCLKp0	RESERVED	48
49	REFCLKn0	SUSCLK(32kHz)	50

51	GND	PERST0#	52
53	CLKREQ0#	W_DISABLE2#	54
55	PEWAKE0#	W_DISABLE1#	56
57	GND	NC	58
59	RESERVED	NC	60
61	RESERVED	NC	62
63	GND	RESERVED	64
65	RESERVED	NC	66
67	RESERVED	NC	68
69	GND	NC	70
71	RESERVED	3.3V	72
73	RESERVED	3.3V	74
75	GND		

6.6.3 - M.2 M-Key

Pin	Function	Function	Pin
1	GND	3.3 V	2
3	GND	3.3 V	4
5	PERn3	NC	6
7	PERp3	NC	8
9	GND	DAS/DSS (I/O)/LED_1# (I)(0/3.3V)	10
11	PETn3	3.3 V	12
13	PETp3	3.3 V	14
15	GND	3.3 V	16
17	PERn2	3.3 V	18
19	PERp2	NC	20
21	GND	NC	22
23	PETn2	NC	24
25	PETp2	NC	26
27	GND	NC	28
29	PERn1	NC	30
31	PERp1	NC	32
33	GND	NC	34
35	PETn1	NC	36
37	PETp1	DEVSLP (O)	38

39	GND	SMB_CLK (I/O)(0/1.8V)	40
41	PERn0/SATA-B+	SMB_DATA (I/O) (0/1.8V)	42
43	PERp0/SATA-B-	ALERT# (I) (0/1.8V)	44
45	GND	NC	46
47	PETn0/SATA-A-	NC	48
49	PETp0/SATA-A+	PERST# (O)(0/3.3V) or NC	50
51	GND	CLKREQ# (I/O)(0/3.3V) or NC	52
53	REFCLKn	PEWAKE# (I/O)(0/3.3V) or NC	54
55	REFCLKp	NC	56
57	GND	NC	58
	CONNECTOR Key M	CONNECTOR Key M	
	CONNECTOR Key M	CONNECTOR Key M	
	CONNECTOR Key M	CONNECTOR Key M	
	CONNECTOR Key M	CONNECTOR Key M	
67	NC	SUSCLK(32kHz) (O)(0/3.3V)	68
69	PEDET (NC-PCIe/GND-SATA)	3.3 V	70
71	GND	3.3 V	72
73	GND	3.3 V	74
75	GND		

6.7 - Appendix G: Safety Information

Do not open or modify the device. Modification of the device may void these certifications.

6.7.1 Safe use and installation instructions

1. Install the device securely. Be careful handling the device to prevent injury and do not drop.
2. To protect against excessive RF exposure, maintain at least 20cm from any user and the RF antennas. Only use provided dual band PIFA antennas with 2dBi/2dBi gain (2.4 and 5Ghz) for Wifi/BT.
3. Wall or ceiling mounting device requires use of a mounting plate or bracket. The plate or bracket must be of metal construction and have a minimum thickness of 1mm.
4. Use M3x0.5mm Flat Head screws to attach mounting plate or mounting brackets to threaded holes on bottom or rear of chassis. Screws should be a minimum length of 4mm. Add 1mm of screw length for every mm of additional thickness of plate or bracket beyond 1.5mm.
5. Ambient operating temperature must be between 0 °C to 50 °C with a non-condensing relative humidity of 10-90%.
6. The device can be stored at temperatures between -10 °C to 85 °C.
7. Keep the device away from liquids and flammable materials.
8. Do not clean the device with liquids. The chassis can be cleaned with a cloth.
9. Allow at least 2 inches of space around all sides of the device for proper cooling. If the device is mounted to a vertical surface then recommended device orientation is so that heatsink fins allow air to rise unobstructed. Alternative orientations may result in reduced operational

temperature range.

10. This device is intended for indoor operation only.
11. Use only the UL ITE Listed external power supplies provided. DC input of 9-24Vdc allowable when provided from a recognized ITE Listed power source of 5A minimum.
12. Install the device only with shielded network cables.
13. The installer should be experienced in aftermarket installation and familiar with general practices for installing electronics.
14. Service and repair of the device must be done by qualified service personnel. This includes, but is not limited to, replacement of the CMOS battery. Replacement CMOS battery must be UL recognized and of a similar type as the original.
15. Proper disposal of CMOS battery must comply with local governance.
16. Radio device is not intended for emergency service use.



WARNING: There is danger of explosion if the CMOS battery is replaced incorrectly. Disposal of battery into fire or a hot oven, or mechanically crushing or cutting of a battery can result in an explosion.

6.7.2 Précautions et guide d'installation

1. Ne pas ouvrir ou modifier l'appareil. L'appareil utilise des composants conformes aux réglementations FCC et EC. La modification de l'appareil peut annuler ces certifications.
2. Installez l'appareil en toute sécurité. Soyez prudent lors de la manipulation de l'appareil pour éviter les blessures et ne pas faire tomber.
3. Le montage au mur ou au plafond nécessite l'utilisation d'une plaque de montage ou d'un support. La plaque ou le support doit être en métal et doit avoir une épaisseur minimale de 1 mm.
4. Utilisez des vis à tête plate M3x0,5mm pour fixer la plaque de montage ou les supports aux trous filetés situés au bas ou à l'arrière du châssis. Les vis doivent avoir une longueur minimale de 4 mm. Ajoutez 1 mm de longueur de vis pour chaque mm d'épaisseur supplémentaire de plaque ou de support dépassant 1,5 mm.
5. La plage de températures de fonctionnement doit être de 0 °C à 50 °C avec une humidité relative de 10 à 90% sans condensation. La température de fonctionnement dépend du choix du composant, y compris de l'adaptateur d'alimentation. Voir le tableau 1 ci-dessous pour le déclassement.
6. La plage de températures de stockage doit être de -10 °C à 85 °C.
7. Gardez l'appareil à l'écart des liquides et des matières inflammables.
8. Ne nettoyez pas l'appareil avec des liquides. Le châssis peut être nettoyé avec un chiffon.
9. Laissez au moins 5 cm d'espace autour de tous les côtés de l'appareil pour un refroidissement correct. Si l'appareil est monté sur une surface verticale, l'orientation recommandée est telle que les ailettes du dissipateur de chaleur permettent à l'air de monter sans obstruction. Les orientations alternatives peuvent entraîner une réduction de la plage de température de fonctionnement.
10. Cet appareil est conçu uniquement pour une utilisation en intérieur.
11. Utilisez une alimentation externe listée UL avec une sortie nominale de 9-24Vdc.
12. Installez l'appareil uniquement avec des câbles réseau blindés.
13. L'entretien et la réparation de l'appareil doivent être effectués par du personnel qualifié. Cela inclut, sans toutefois s'y limiter, le remplacement de la batterie CMOS. La batterie CMOS de remplacement doit être du même type que l'originale.
14. La mise au rebut des batteries usagées doit être réalisée conformément aux réglementations environnementales.



ATTENTION: Il existe un risque d'explosion si la pile CMOS n'est pas remplacée correctement. La mise au rebut de la batterie au feu ou dans un four chaud, ou l'écrasement ou la coupure mécanique d'une batterie peut entraîner une explosion.

6.8 - Appendix H: Errata

6.8.1 IP-1: RS422 and RS485 Require SerCx2

Overview

Category:	Software / Drivers
SKU(s) Affected:	HX310, HX330
Revision(s) Affected:	All release hardware
Revision Resolved:	None
Severity:	Low

Description

Setting the HX300 to use RS422 or RS485 serial modes on Windows requires using the SerCx2.sys driver framework. Most existing serial utilities only support the Serial.sys driver framework, requiring the use of [Windows APIs](#) to use the RS422/485 serial device.

RS232 serial mode uses the Serial.sys driver framework.

Workaround

A UART Sub-Device driver is [available for download](#), and provides a mapping layer to the Serial.sys driver framework. This driver does not support setting the DTR/DTS hardware lines, which may result in compatibility issues with some software packages, including PuTTY.

Resolution

There are no planned changes to the serial framework.

6.8.2 IP-2: System May Power On After Power Interruption

Overview

Category:	Hardware
SKU(s) Affected:	HX310, HX330
Revision(s) Affected:	All release hardware
Revision Resolved:	Unresolved
Severity:	Low

Description

In some cases, after an input power glitch, the system may power on. Brownouts, or other power events, may result in a previously off system powering on to the BIOS or operating system.

Workaround

None

Resolution

Investigating

6.8.3 IP-3: Wake-On-LAN Does Not Function

Overview

Category:	Hardware
SKU(s) Affected:	HX310, HX330
Revision(s) Affected:	All release hardware
Revision Resolved:	Unresolved
Severity:	Low

Description

The Wake-On-LAN feature does not wake the system from any power states

Workaround

None

Resolution

Investigating