

# HX401 Industrial Computer

## Product Manual

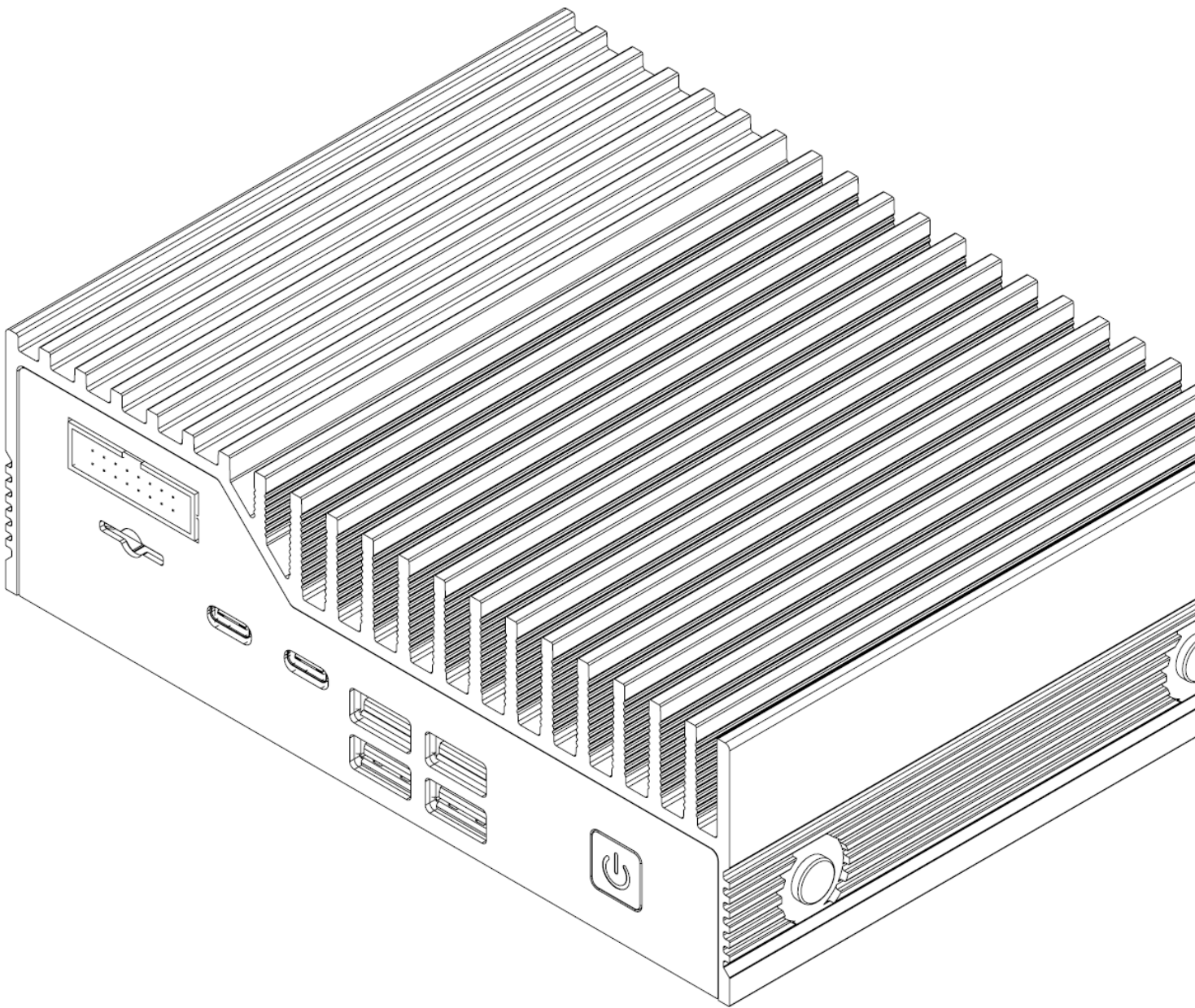

# Revision History

Revision History	Date
Initial Release	03/06/2023
Revision 1.1 - minor updates	03/31/2023
Revision 2.0 - Addition of Thunderbolt 4	06/14/2023

# Table of Contents

Safety Precautions, Safeguards & Information	4
<b>1 - System Overview</b>	<b>8</b>
1.1 - System Introduction	8
1.2 - Accessories	8
1.3 - Product Specifications	9
1.4 - Exterior Features and Dimensions	11
1.4.1 - Front I/O	11
1.4.2 - Back I/O	11
1.4.3 - Helix 401 Dimensions	12
1.5 - System Block Diagram	13
<b>2 - I/O Definitions</b>	<b>14</b>
2.1 - Front I/O Definition	14
2.2 - Rear I/O definition	16
2.3 - Motherboard Connectors	21
2.4 CPU	26
<b>3 - Mounting Instructions</b>	<b>26</b>
3.1 - Wall Mount & DIN Rail Mounting	26
3.2 - VESA Mounting	27
<b>4 - Power Management</b>	<b>28</b>
4.1 - Wake-Up Events	28
4.2 - Protection Circuitry	29



<b>5 - Regulatory Compliance</b>	<b>29</b>
5.1 - CE	29
5.2 - FCC Statement	29
5.3 - ISED (Innovation, Science and Economic Development Canada)	29
5.4 - UKCA	30
5.5 - VCCI	30
<b>6 - Appendices</b>	<b>30</b>
6.1 - Appendix A: Power consumption	30
6.2 - Appendix B: Isolated DIO guide	33
6.3 - Appendix C: BIOS manual	33
6.4 - Appendix D: CAN user guide	33
6.5 - Appendix E: System thermal results	33
6.5.1 Test Conditions	33
6.5.2 Test Results	34
6.5.3 Test Result Summary	34
6.6 - Appendix F: Expansion port pinout	34
6.6.1 - M.2 B-Key	34
6.6.2 - M.2 E-Key	35
6.6.3 - M.2 M-Key	37

## Safety Precautions, Safeguards & Information

Do not open and modify the device! The device complies with various national and international Safety, EMC and Environmental requirements per various standards.

Modification of the device may void certifications, warranty and/or cause possible injury to the user.

### Safe use and installation instructions

1. Care must be taken handling the device to prevent injury to self or possibility of damaging the unit.
2. Read the entire manual before using the product.
3. Install the device securely per users manual instructions.
4. Wall or ceiling mounting device requires use of OnLogic mounting plate or bracket.
5. Use M3x0.5mm Flat Head screws to attach mounting plate or mounting brackets to threaded holes on bottom or rear of chassis. Screws should be a minimum length of 4mm. Add 1mm of screw length for every mm of additional thickness of plate or bracket beyond 1.5mm.
-  6. **Caution, Hot Surface!** It is normal for the unit to heat up and be hot to touch. **Do not touch the heatsink area or enclosure during operation and 30 minutes after shutdown allowing the unit to cool down.**
7. Ambient operating temperature must be between 0 °C to 50 °C with a non-condensing relative humidity of 10-85%.
8. The device can be stored at temperatures between -10 °C to 85 °C. Note: Unit must be stabilized within operating temperature before use, minimum 3HR.
9. Keep the device away from liquids and flammable materials. Not to be installed in a hazardous environment.
10. Do not clean the device with liquids. The chassis can be cleaned with a dry cloth or duster only. To prevent injury to self and/or damage to the device the unit must be powered down and all connecting power and other peripherals shall be disconnected prior to cleaning.
11. Allow adequate space around all sides of the device for proper cooling and to not exceed its maximum operating temperature limit. If the device is mounted to a vertical surface then recommended device orientation is such that heatsink fins allow air to rise unobstructed. Alternative orientations may result in reduced operational temperature range.
-  12. This device is intended for indoor operation only.
13. **Caution, Risk of Electric Shock!** Unit is powered by low voltage DC (Direct Current) only! Do not connect AC (Alternating Current) into the device!
14. To power the device use only UL ITE Listed external power supplies with DC output of 12-24VDC, see specs for details.
15. Install the device only with shielded network cables.
16. The installer should be experienced in aftermarket installation and familiar with general practices for installing electronics.
17. Service and repair of the device must be done by qualified skilled service personnel. This includes, but is not limited to, replacement of the CMOS battery. Replacement CMOS battery must be UL recognized and of a similar type as the original.

18. Proper disposal of the CMOS battery must comply with local governance.
19. Radio device is not intended for emergency service use.
20. To protect against excessive RF exposure, maintain at least 20cm from any user and the RF antennas. Only use provided dual band PIFA antennas with 2dBi/2dBi gain (2.4 and 5Ghz) for Wifi/BT.
21. This equipment is not suitable for use in locations where children are likely to be present.





**WARNING:** There is danger of explosion if the CMOS battery is replaced incorrectly. Disposal of battery into fire or a hot oven, or mechanically crushing or cutting of a battery can result in an explosion.

## Précautions de sécurité, sauvegardes et informations

Ne pas ouvrir et modifier l'appareil ! L'appareil est conforme à diverses exigences nationales et internationales en matière de sécurité, de CEM et d'environnement selon diverses normes.

La modification de l'appareil peut annuler les certifications, la garantie et/ou causer des blessures à l'utilisateur.

### Instructions d'utilisation et d'installation en toute sécurité

1. Des précautions doivent être prises lors de la manipulation de l'appareil pour éviter de se blesser ou d'endommager l'appareil.
2. Lisez l'intégralité du manuel avant d'utiliser le produit.
3. Installez l'appareil en toute sécurité selon les instructions du manuel de l'utilisateur.
4. Le dispositif de montage au mur ou au plafond nécessite l'utilisation d'une plaque de montage ou d'un support OnLogic.
5. Utilisez des vis à tête plate M3x0,5 mm pour fixer la plaque de montage ou les supports de montage aux trous filetés au bas ou à l'arrière du châssis. Les vis doivent avoir une longueur minimale de 4 mm. Ajoutez 1 mm de longueur de vis pour chaque mm d'épaisseur supplémentaire de plaque ou de support au-delà de 1,5 mm.
-  6. **Attention, surface chaude!** Il est normal pour les unités de se réchauffer et de devenir chaude au toucher. Évitez de toucher les surfaces de dissipation de chaleur ou le boîtier pendant l'utilisation ou jusqu'à 30 minutes après l'arrêt pour permettre à l'unité de se refroidir.
7. La température ambiante de fonctionnement doit être comprise entre 0 °C et 50 °C avec une humidité relative sans condensation de 10 à 85 %.
8. L'appareil peut être stocké à des températures comprises entre -10 °C et 85 °C. Remarque : L'unité doit être stabilisée à la température de fonctionnement avant utilisation, minimum 3 heures.
9. Gardez l'appareil à l'écart des liquides et des matériaux inflammables. Ne pas installer dans un environnement dangereux.
10. Ne nettoyez pas l'appareil avec des liquides. Le châssis peut être nettoyé uniquement avec un chiffon sec ou un plumeau. Pour éviter de se blesser et/ou d'endommager l'appareil, l'appareil doit être éteint et toutes les alimentations et autres périphériques doivent être déconnectés avant le nettoyage.
11. Prévoyez un espace suffisant autour de tous les côtés de l'appareil pour un refroidissement correct et pour ne pas dépasser sa limite de température de fonctionnement maximale. Si l'appareil est installé sur une surface verticale, l'orientation recommandée de l'appareil est telle que les ailettes du dissipateur thermique permettent à l'air de monter sans obstruction. Des orientations alternatives peuvent entraîner une plage de températures de fonctionnement réduite.
-  12. Cet appareil est destiné à une utilisation en intérieur uniquement
13. **Avertissement! Risque de choc électrique !** L'unité est alimentée uniquement par une basse tension CC (courant continu) ! Ne connectez pas le courant alternatif (courant alternatif) à l'appareil !

14. Pour alimenter l'appareil, utilisez uniquement des alimentations externes répertoriées UL ITE avec un puissance de sortie CC de 12-24 VCC, voir les spécifications pour plus de détails.
15. Installez l'appareil uniquement avec des câbles réseau blindés.
16. L'installateur doit avoir de l'expérience dans l'installation du marché secondaire et être familiarisé avec les pratiques générales d'installation de l'électronique.
17. L'entretien et la réparation de l'appareil doivent être effectués par un personnel d'entretien qualifié et qualifié. Cela inclut, mais sans s'y limiter, le remplacement de la batterie CMOS. La batterie CMOS de remplacement doit être reconnue UL et d'un type similaire à l'original.
18. L'élimination appropriée de la batterie CMOS doit être conforme à la gouvernance locale
19. L'appareil radio n'est pas destiné aux services d'urgence..
20. Pour vous protéger contre une exposition RF excessive, maintenez au moins 20 cm de tout utilisateur et des antennes RF. Utilisez uniquement les antennes PIFA double bande fournies avec un gain de 2 dBi/2 dBi (2,4 et 5 Ghz) pour le Wifi/BT.
21. Cet équipement n'est pas adapté à une utilisation dans des endroits où des enfants sont susceptibles d'être présents.



**AVERTISSEMENT** : Il existe un risque d'explosion si la pile CMOS n'est pas remplacée correctement. L'élimination de la batterie dans le feu ou dans un four chaud, ou l'écrasement ou le découpage mécanique d'une batterie peut entraîner une explosion.



# 1 - System Overview

## 1.1 - System Introduction

The Helix 401 (HX401) harnesses the enhanced power and capabilities of Intel “Alder Lake P” Core and Celeron processors in a low profile fanless system built for the challenges of the IoT edge. With support for four independent 4K displays, a 0°C to 50°C operating temperature range, and a wealth of configuration options, the Helix 401 was engineered with versatility in mind. The systems also feature compliance testing for IT Equipment EMC and Safety and pre-compliance testing for IEC 60601-1-2 (4th edition) medical immunity.

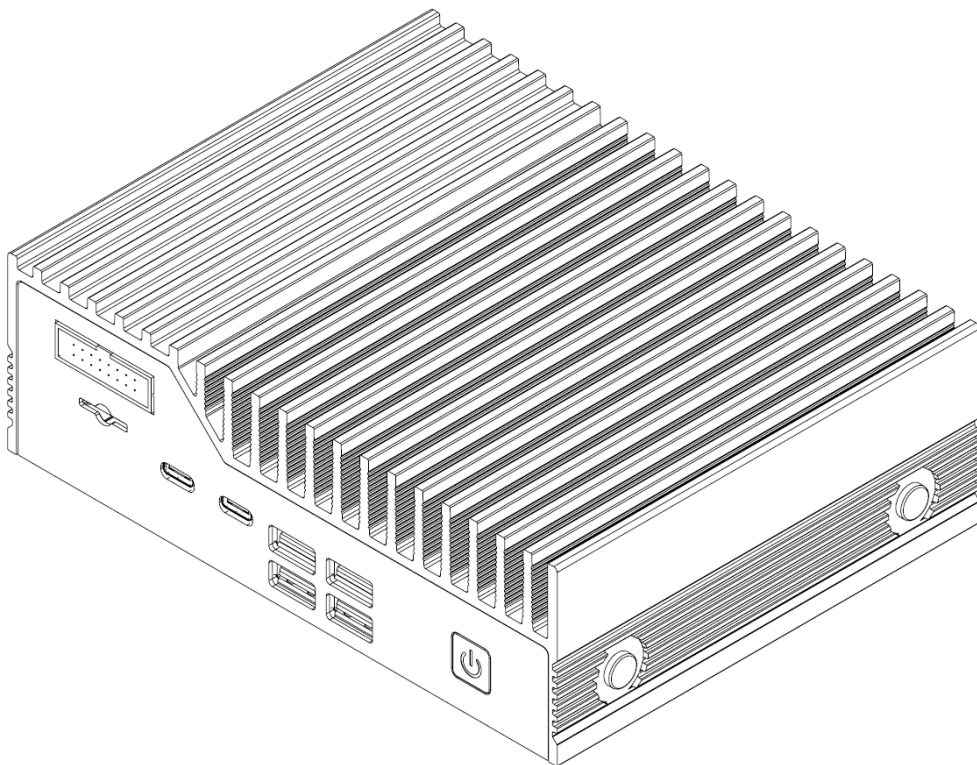

## 1.2 - Accessories

If you purchased additional items such as mounting brackets, power supplies or terminal block connectors, they will be located in the system box or within the outer shipping carton.

All drivers and product guides can be found on the corresponding product page. For more information on accessories and additional features, visit the Helix Product pages.

Helix 401 Product Page: <https://www.onlogic.com/hx401/>



## 1.3 - Product Specifications

OnLogic HX400 Series	
<b>Processor</b>	Intel 12th Gen Alder Lake-P Celeron 7305E Core i3 - 1220 PE Core i5 - 1250PE Core i7 - 1270PE
<b>Memory</b>	2x DD5-4800 SO-DIMM up to 64GB total (non-ECC)
<b>Integrated Graphics</b>	Intel® UHD Graphics for 12th Gen Intel® Processors (7305E, i3-1220PE) Intel® Iris® Xe (i5-1250PE, i7-1270PE) - Dual Channel DDR5 memory required
<b>Front I/O</b>	1x Power Button (LED Backlit) 4x USB 3.2 Gen 2 2x Thunderbolt 4, USB Type C (40 Gb/s) 3FF-Sim slot (Mapped to the B-Key) 1x DIO port Punch out
<b>Back I/O</b>	2x Full size DisplayPort 1.4a 2x Gb LAN Terminal Block Option - Punch out 2x Antenna punch outs 1x Serial/CAN Punch out Barrel Jack with 19~24 V input
<b>Expansion &amp; Storage</b>	1x M.2 2280/60/3042 B-Key (PCIe Gen 3 x1, USB 3.0, SATA III) 1x M.2 2230 E-key (Wi-Fi) (PCIe x1/ USB 2.0) 1x M.2 2280 M-key (PCIe Gen 4 x 4, SATA III)
<b>Onboard Headers &amp; Connectors</b>	1x Battery on a cable 1x Serial Header, RS 232/422/485 2x USB 2.0 (1x4 header) 16 Pin input for Terminal Block Power
<b>Special Features</b>	Watchdog timer RTC Onboard TPM - Infineon SLB9672 BIOS option for auto power-on
<b>Optional Add On Module</b>	4G, CAN Bus, COM (RS-232/422/485), DIO (x4/x4), Terminal Block
<b>Operating Systems</b>	Windows 11 Pro 64 Bit* Windows 10 IoT Enterprise 2021 LSC Value (Celeron/i3/i5) / High End (i7) Ubuntu 22.04 Desktop / Server IOT *Limited support - Refer to <a href="https://support.onlogic.com/documentation/onlogic-and-intel-collaboration/">support.onlogic.com/documentation/onlogic-and-intel-collaboration/</a>
<b>LAN controller</b>	1x Intel I219 and 1x Intel I210
<b>Voltage Input</b>	rated input: 19~24V via DC jack or 12~24V via Terminal Block, +/- 10% tolerance

<b>Power Input</b>	Barrel Jack with optional 4-pin Terminal Block (support for remote switch, Barrel Jack covered when not in use.)
<b>Power Protections</b>	TVS for power input protection Moderate disturbance protection with a TVS LC filter. Alternate DC supplies should be IT equipment rated when possible.
<b>Dimensions</b>	160 x 123 x 50 mm
<b>Weight</b>	~1.20 kg / 2.65 lbs (System Only)
<b>Motherboard Dimensions</b>	142 x 117 x 24mm max
<b>Mounting Options</b>	DIN Wall VESA
<b>Thermal Standards, Subject to Change through RFI and RFQ steps</b>	System Operating Temperature: 0-50C Board Operating Temperature: 0-65C Storage Temperature: -10-85C Operating Humidity: 0% - 90%
<b>Radio Specifications when equipped with INT-9260 Wifi/BT (device for indoor use)</b>	
<b>Frequency Bands</b>	2.4GHz and 5GHz bands
<b>Operating Frequency</b>	2400 - 2485 MHz 5150 - 5250 MHz, 5250 - 5350 MHz 5470 - 5725 MHz, 5725 - 5878 MHz
<b>Channel spacing / Bandwidth</b>	2.4GHz: 802.11b/g/n; 5 MHz / BT: 1MHz Bandwidth: 20 MHz / 40 MHz 5 GHz: 802.11a/n/ac: 20, 40, 80, 160 MHz
<b>RF output power</b>	20dBm (2400-2485 MHz) IEEE 802.11b/g/n& BT 10dBm (2400-2485 MHz) BLE 23dBm (5150-5725 MHz) IEEE 802.11a/n/ac 13.98 dBm (5725-5875MHz) IEEE 802.11a/n/ac
<b>Type of Modulation</b>	2.4GHz: DSSS/OFDM/FHSS 5 GHz: OFDM
<b>Antenna Specifications</b>	ANT200 - PIFA type with 2dBi/2dBi gain on 2.4 & 5 GHz
<b>Modes of operation</b>	Duplex (Tx/Rx)
<b>Duty cycle (access protocol)</b>	As In: IEEE 802.11 a/b/g/n/ac
<b>Version of firmware /software</b>	Software Intel PROSet/Wireless WiFi Software 20..x and following versions for WIFI/BT

## 1.4 - Exterior Features and Dimensions

### 1.4.1 - Front I/O

The HX401 is pictured with the optional DIO module installed.

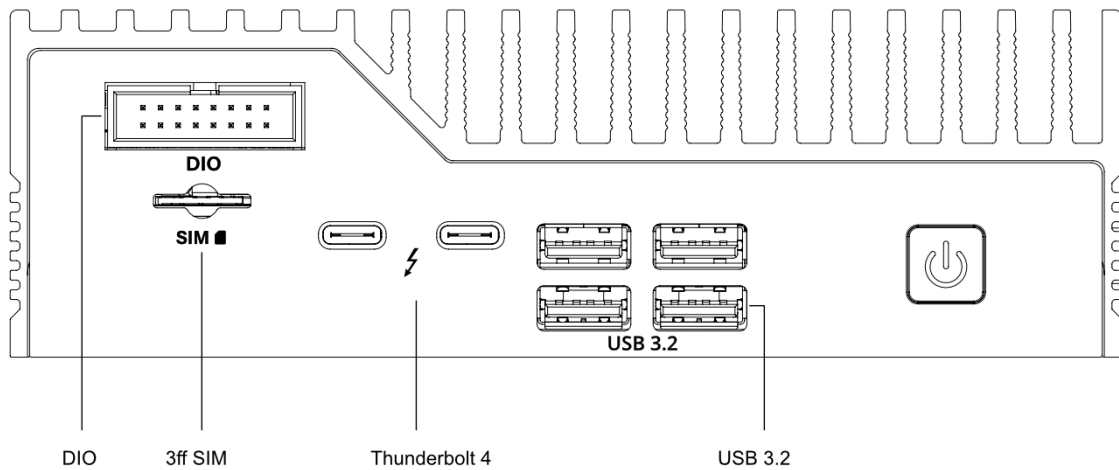

### 1.4.2 - Back I/O

The HX401 is pictured with the optional CAN module and optional terminal block connector shown alongside the DC Barrel.

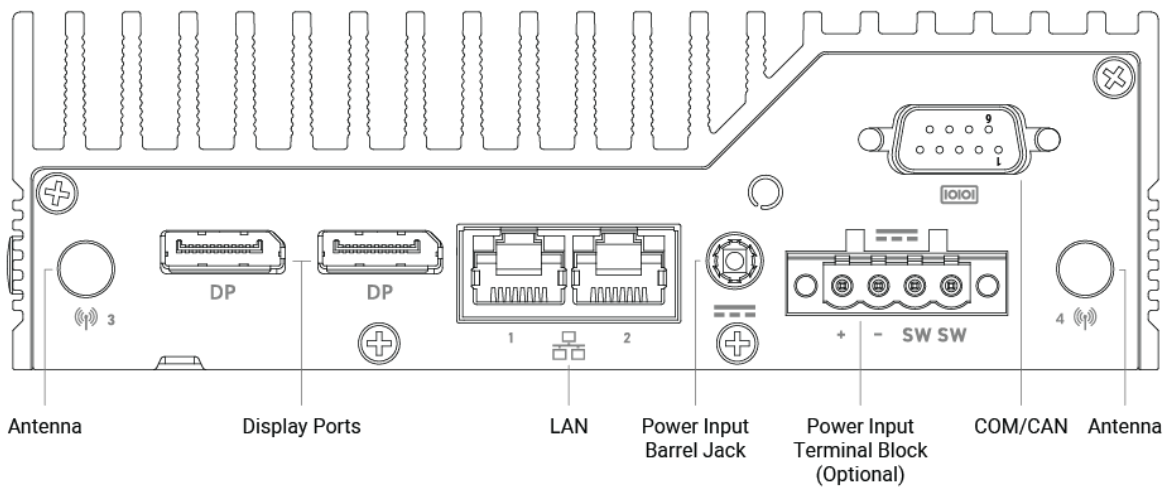

### 1.4.3 - Helix 401 Dimensions

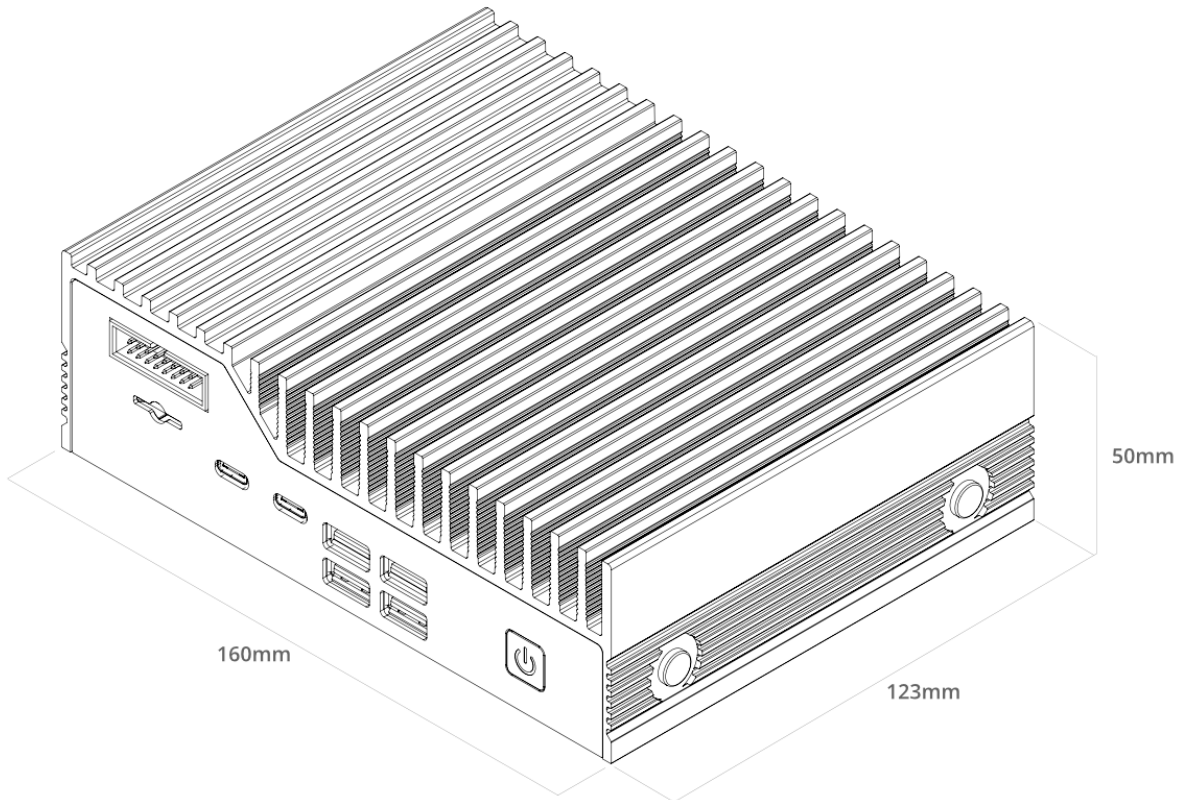

# 1.5 - System Block Diagram

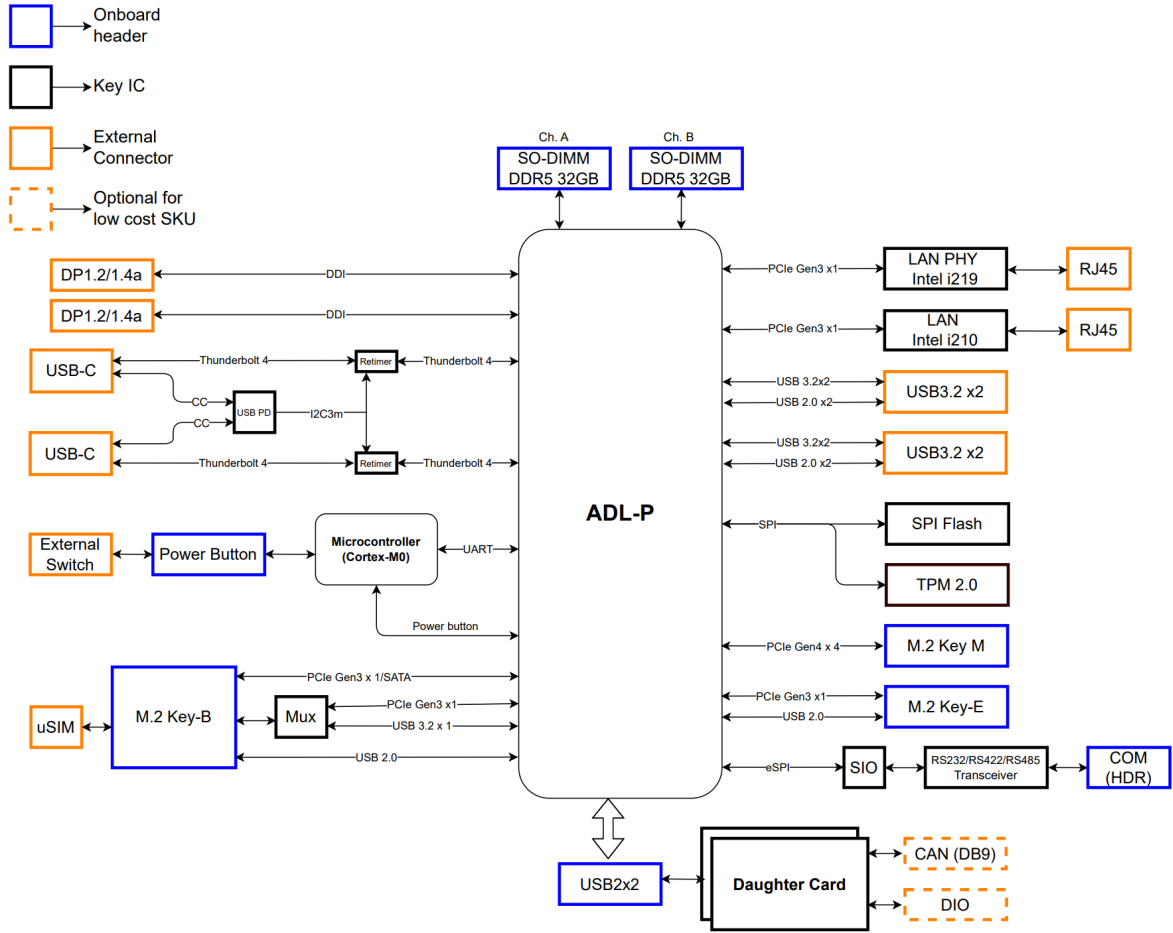

## 2 - I/O Definitions

### 2.1 - Front I/O Definition

The HX401 with the DIO option is pictured.

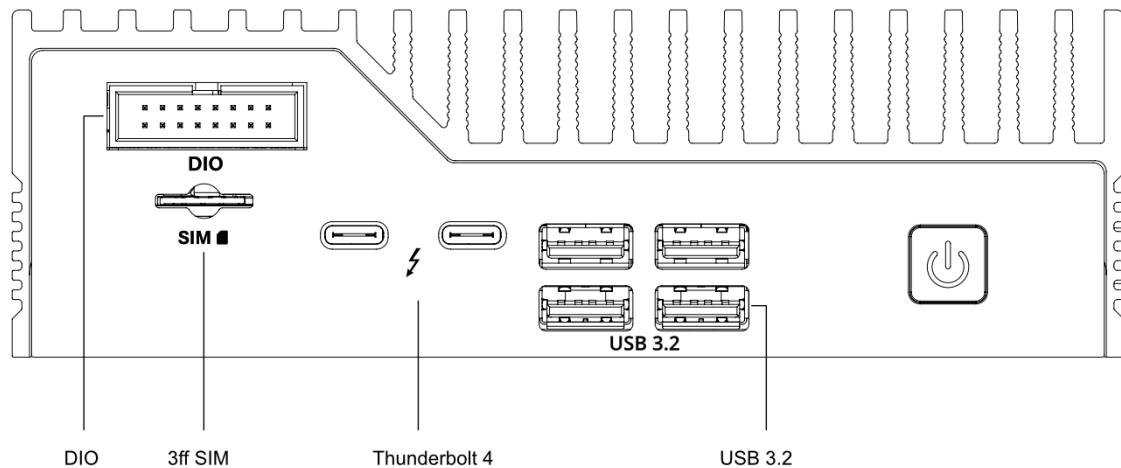

### Power Button / Power LED

The front power button can be used to turn on and off the Helix system. The power button is a momentary contact button with a blue LED backlight used to display the status of the system. A single press while the system is on will initiate a graceful shutdown operation from the OS. Pressing and holding the button for 4 seconds while the system is running will cause a hard reset of the system. The system can be woken by a single press of the power button from any state.

The LED backlight will indicate the system status. A solid blue light indicates that the system is powered in the S0 state. A flashing blue light indicates the system is in the sleep state. The LED is off in S5 and deep sleep states.

### SIM Card

A 3FF Subscriber Identity Module (SIM) card slot is present on the front panel of the HX401 allowing native support for OnLogic 4G LTE modules. The SIM signals are connected to the M.2 B-Key internal expansion slot.

The SIM slot is a Push-Push type receptacle. To insert or remove the SIM card from the front panel of the Helix platform, please use a small implement to push the card into the slot until it clicks. To remove the card, push with a small implement until the card clicks, then pull on the free end of the card to remove it.

## Thunderbolt 4 (Type C USB port)

There are two Thunderbolt 4 ports on the front panel of the HX401 that support total power up to 22.5 Watts. This port is capable of linking up to 40Gb/s transfer rates.

- USB Type C connector
- Power output up to 5V/3A for the first port and 5V/1.5A for the second port. Power will be allocated on a first-come first-serve basis between the first and second ports.
- Up to 40 Gbps data transfer rate
- DisplayPort 1.4 compliant in DisplayPort Alt Mode
- Supports SuperSpeed USB 10 Gbps; backwards compatible with SuperSpeed USB 5 Gbps and USB 2.0.

*Note: Type-C power sink mode is not supported on Helix 401.*

## USB 3.2

There are two dual stack USB 3.2 Gen 2 ports on the front panel of the Helix mainboard. Each port is capable of linking at 10Gb/s transfer rates.

## USB 2.0

There are two USB 2.0 headers on the Helix 401 mainboard. This port is capable of linking at 480 Mb/s transfer rates.

## DIO option

The Helix platform supports an optional Isolated Digital I/O add-in card (OnLogic ADP120). This option allows for integration of the Helix platform with existing PLC integrations or other digital logic applications. For a complete explanation of features, operating voltages, and safety information, please refer to the DIO expansion manual on the OnLogic support site.

<https://www.onlogic.com/support/documentation/adp102-dio/>

## 2.2 - Rear I/O definition

The HX401 with optional CAN installed. Additionally, the DC power barrel and terminal block power input options are both shown.



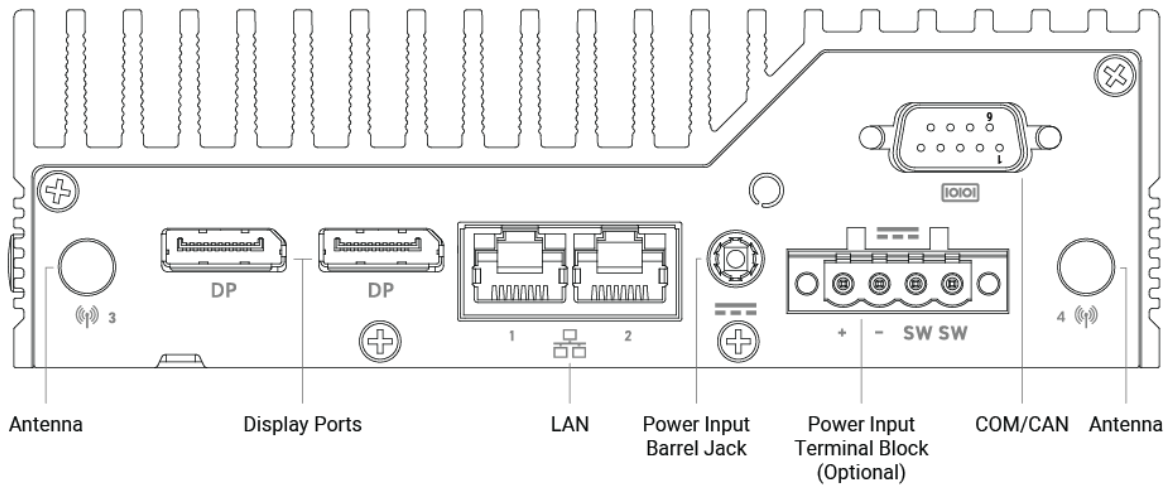

## Barrel Jack Power Connector

Mainboard power is applied to the Helix platform by way of a female barrel jack connector (OD: 5.5mm ID: 2.5mm. 12mm length ). The system is operational from 19V~24V. The maximum rated current of the connector is 7A. Use a wire gauge that is rated for the operational current. See below for on-board connector pinout.



Center Positive

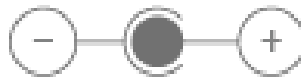

Barrel Jack power pinout

*Note: Located above the power barrel is a sheet metal punch-out for the plastic cable retention clamp. To use this feature the sheet metal tab needs to be removed with the backplate uninstalled to ensure the tab does not break off into the system.*

## DisplayPort 1.4a

Helix utilizes Intel's Integrated Gen 12 processor graphics that power the onboard DisplayPorts 1.4a. This means resolutions up to 4096x2160 @ 60Hz are supported on both outputs simultaneously. All ports support Multi-Stream Transport (MST).

## LAN1(vPRO) - Intel I219-LM

The Intel I219 LAN Port on Helix supports up to 1Gbps link speeds over standard shielded CAT5e or CAT6 cables. The connector is the industry standard RJ45 connector. This port also features Intel's vPro(R) technology enabling remote out-of-band management and security features (requires Intel Core i5 or higher). The LAN link state is shown by the two LEDs enclosed in the port. The description is included below.

## LAN2 - Intel I210-IT

The second LAN Port on Helix supports up to 1Gbps link speeds over standard shielded CAT5e or CAT6 cables. The connector is the industry standard RJ45 connector. The LAN link state is shown by the two LEDs enclosed in the port. The description is included below.

	LED	State	Function
<p>The diagram shows a top-down view of an RJ45 port. On the left side, there is a green LED labeled 'LED 1'. On the right side, there is a multi-colored LED labeled 'LED 2', which is primarily orange with a green section at the bottom.</p>	LED1	Blinking Green	1Gb/s activity
	LED2	Blinking Orange	100 Mb/s activity
Blinking Green		10 Mb/s activity	

LAN activity light description

## COM DB9 Option

The serial port mode and voltage between Off/5V on Pin 9 on Helix can be selected in the BIOS configuration. The serial ports support RS-232, RS-422, and RS-485 configurations. Refer to the BIOS manual in Appendix C for configuration instructions.

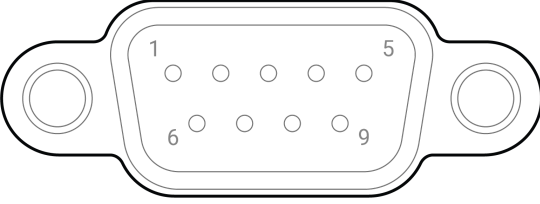
	Pin	RS-232	RS-422	RS-485
	1	DCD	<b>TX-</b>	<b>TX-/RX-</b>
	2	RX	<b>TX+</b>	<b>TX+/RX+</b>
	3	TX	<b>RX+</b>	<b>NC</b>
	4	DTR	<b>RX-</b>	<b>NC</b>
	5	GND	<b>NC</b>	<b>NC</b>
	6	DSR	<b>NC</b>	<b>NC</b>
	7	RTS	<b>NC</b>	<b>NC</b>
	8	CTS	<b>NC</b>	<b>NC</b>
	9	RI/PWR	NC/PWR	NC/PWR

COM DB9 pinout

## CAN DB9 option

The CAN port on Helix 401 supports CAN2.0 A/B at baud rates from 100-1000 kbaud. The system CAN port is not internally terminated, and a properly terminated (120 Ohms, typical) cable should be used. The communication protocol used to send and receive messages is detailed on the [support website](#).

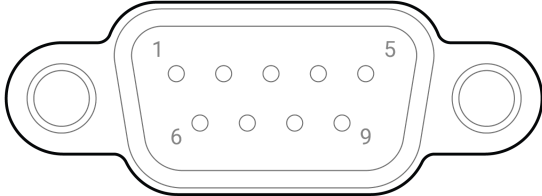
	Pin	Signal
	1	CAN_2_L
	2	CAN_1_L
	3	GND
	4	NC
	5	NC
	6	GND
	7	CAN_1_H
	8	CAN_2_H
9	NC	

COM DB9 pinout

### Terminal block power option

If the terminal block power option is selected, mainboard power is applied to the Helix platform through a 4-pin terminal block connector (Mating part: Dinkle #2ESDVM-04P-BK or equivalent).

The system is operational from 12V~24V (HX401) [see section 4.3 for input voltage qualifications]. The maximum rated current of the connector is 15A per pin. Use a wire gauge that is rated for the

operational current. Cables should be properly terminated with wire ferrules. Do not use the terminal block with tinned wire ends or solid core wire. See below for the connector pinout which is also indicated on the terminal block mounting panel adjacent to the connector. Installation of DC Mains connection shall only be performed by skilled personnel and in accordance with your local and national electrical code (Example: NEC, CEC).

When using the remote switch connections with the terminal block option, mating power switch cables should be a twisted-pair wire with floating shield to assure proper immunity to EMI/RFI. It is recommended to keep wires at less than 3 meters in length. Switches should be momentary contact type only.

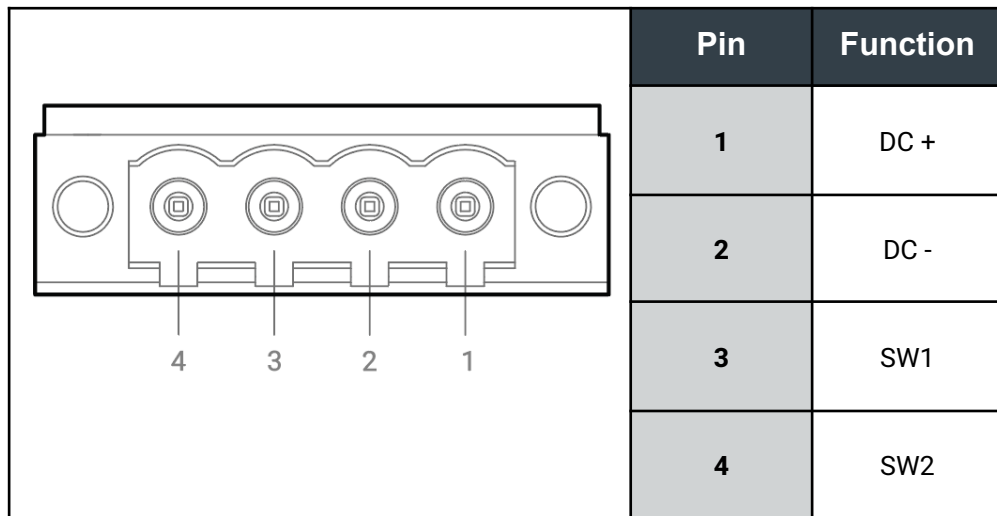

Terminal block power pinout

## 2.3 - Motherboard Connectors

The motherboard top and bottom view for HX401 is as below.

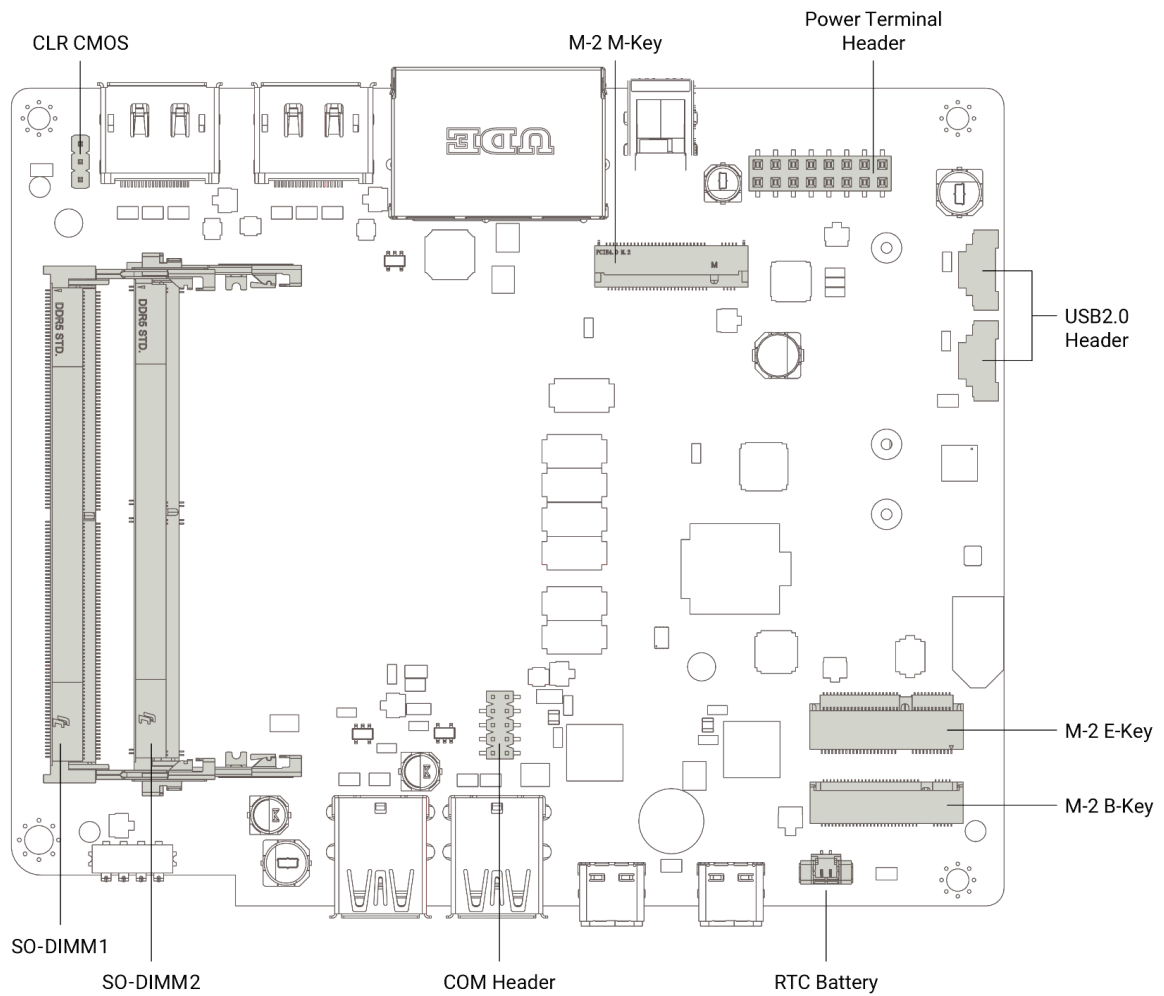

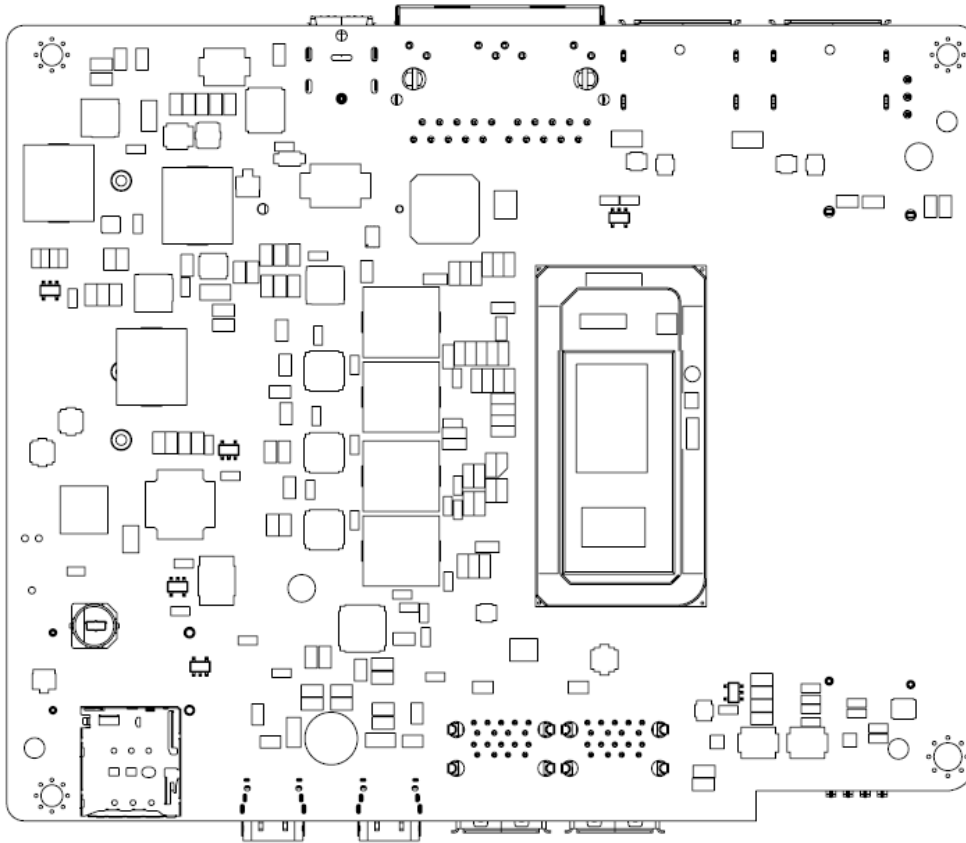

## M.2 B-Key

An M.2 B-Key port is present on the Helix motherboard to allow support for B-Key form-factor expansion cards. Supported cards include 3042, 2242, 3052, 2280 form-factors. The B-Key connector on the Helix platform supports PCIe Gen 3 x2, USB 3.2 10Gb/s, USB 2.0, SATA Gen I (1.5Gbps), SATA Gen II (3.0Gbps), and SATA Gen III (6.0Gbps) devices.

The 3FF Micro SIM card slot is available for OnLogic 4G Extrovert modules.

A full pinout table for this expansion slot is provided in **Appendix F**.

## M.2 E-Key

An M.2 E-Key port is present on the Helix motherboard to allow support for E-Key form-factor wireless expansion cards. Only 2230 form-factor cards are supported. The E-Key connector on the Helix platform supports PCIe Gen 3 x1 and USB 2.0.

A full pinout table for this expansion slot is provided in **Appendix F**.



## M.2 M-Key

An M.2 M-Key port is present on the Helix motherboard to allow support for M-Key form-factor expansion cards. Only 2280 form-factor cards are supported. The M-Key connector on the Helix platform includes support for PCIe Gen4x4 or Gen 3 x4.

A full pinout table for this expansion slot is provided in **Appendix F**

## SO-DIMM1 & SO-DIMM2

The Helix platform has two onboard DDR5 SO-DIMM Slots. Below find the specifications of the two SO-DIMM Slots:

- Maximum Capacity: DDR5-4800 64GB with two 32GB SO-DIMM Modules
- Channel configuration: 1DIMM Per Channel (DPC) - 2 Channels
- No ECC Support

## COM1

The two on-board COM headers utilize standard 9-pin 2.00mm pitch male pin headers with the pin configuration in the chart below. These serial ports support RS-232, RS-422 Full-Duplex, and RS-485 half-Duplex configurations. The serial port communication mode can be selected in the BIOS configuration. In addition, 5V power can be enabled on pin 9 in the same BIOS menu. Pin 9 is rated to provide 150mA of current. Refer to the BIOS manual (**Appendix C**) for configuration instructions.

Pin	RS-232	RS-422	RS-485
1	DCD	TX-	TX-/RX-
2	RX	TX+	TX+/RX+
3	TX	RX+	NC
4	DTR	RX-	NC
5	GND	NC	NC
6	DSR	NC	NC
7	RTS	NC	NC
8	CTS	NC	NC
9	RI/PWR	NC/PWR	NC/PWR
10	(KEY)	(KEY)	(KEY)

Motherboard Serial header pinout

## BIOS EEPROM

If the BIOS needs to be updated, please refer to **Appendix C** for reflashing instructions.

## ATX (Auto Power ON)

Auto Power ON selection made via BIOS Menu

## CMOS Jumper Header

A 2.54mm pin header and jumpers are used to clear the CMOS settings of the Helix platform.

The system CMOS settings can be cleared with the pin jumper. To clear the CMOS the following steps shall be followed:

1. Disconnect system power.
2. Place jumper in the “clear” position.
3. Wait 10 seconds.
4. Remove jumper from the “clear” position and return to default position

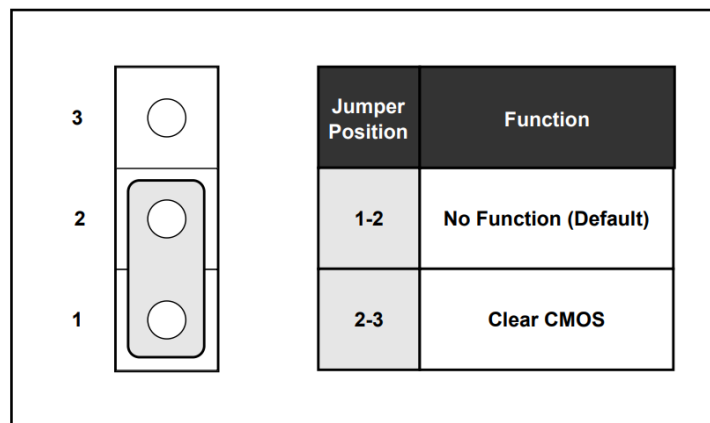

CMOS header pinout

## RTC battery header

The RTC battery on the Helix platform is used to retain BIOS CMOS settings and maintain the real-time clock for the system. If the RTC battery is low, CMOS settings will not be retained and you may receive an alert in the operating system. The cabled RTC battery should be replaced with a Maxell CR2032-WK11 (or UL listed equivalent). An equivalent battery shall use a Hirose DF13-2S-1.25c connector to mate with the on-board connector.

## USB 2.0 Header

The on-board USB 2.0 header provides a single USB 2.0 signal. It utilizes a WR-WTB 4-pin 1.25mm pitch male pin connector with the pin configuration in the chart below. The 5V power pin (Pin 1) can provide up to 1A of current.

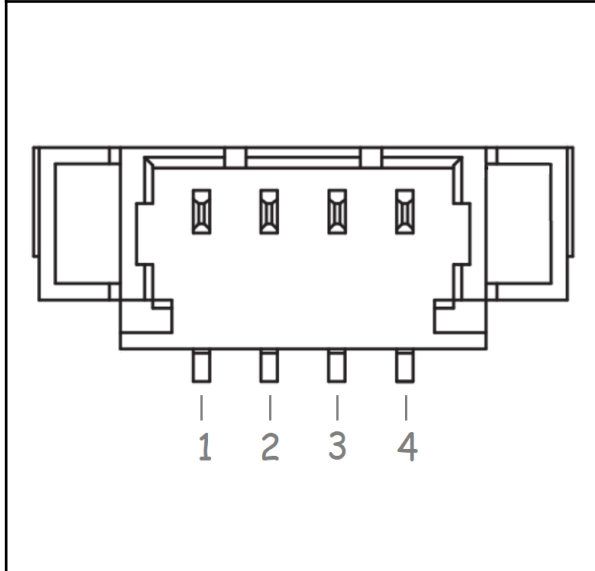
	Pin	Function
	1	5V
	2	D0-
	3	D0+
4	GND	

USB 2.0 header pinout

## Power Input Header

Mainboard power can be applied to the Helix platform by way of OnLogic ADP124 Power Terminal Card. The system is operational from 12V~24V. The maximum rated current of the connector is 3A per pin with a pitch of 2.54mm. Use the Onlogic ADP124 Power Terminal Card with validated functionality and the operational current. See below for connector pinout.

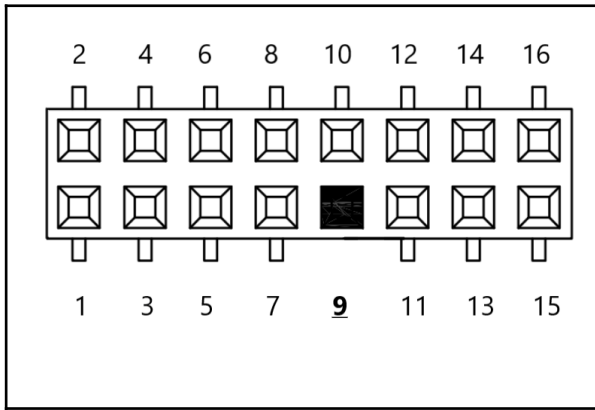
	Pin	Function
1,3,4,5,6,7,8	DC -	
10,11,12,13,14,15,16	DC +	
2	SW+	
9	(Key)	

Motherboard power input pinout

## 2.4 CPU

Four Gen12 CPU options are available for the HX401.

CPU	Onlogic SKU	CPU configuration
Celeron 7305E	HX401-A01-P	5 Core: 1P+4E & 48EU
i3-1220PE	HX401-B01-P	8 Core: 4P+4E & 48EU
i5-1250PE	HX401-C01-P	12 Core: 4P+8E & 80EU
i7-1270PE	HX401-D01-P	12 Core: 4P+8E & 96EU

## 3 - Mounting Instructions

### 3.1 - Wall Mount & DIN Rail Mounting

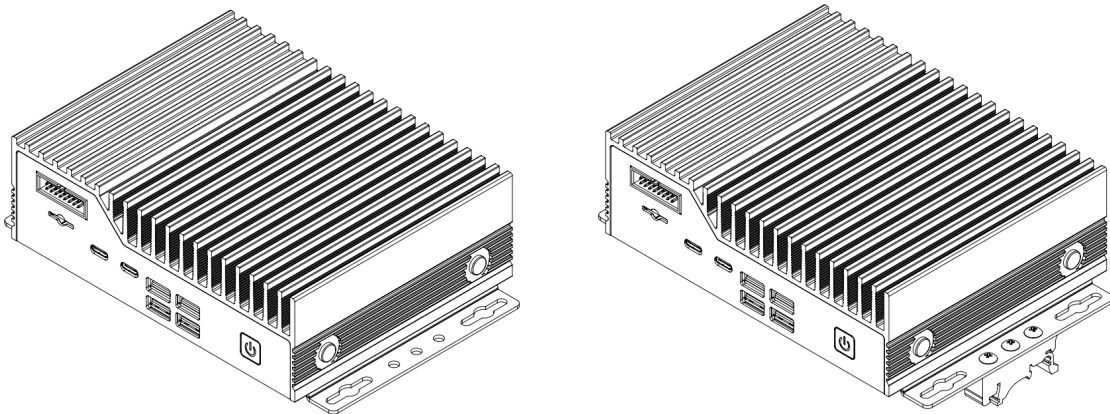

**Step 1:** Align the four screw holes on the bottom of the system with the respective holes on the mounting brackets.

**Step 2:** Attach wall mounting brackets (MTW101) or DIN mount Bracket (MTW101-K), to the system using the supplied M3 screws (M3X0.5 Flathead Screw, 4mm Long)

**Step 3 (Wall Mount only):** Install system to surface using keyhole slots on wall mount brackets and appropriate hardware for the surface (not provided).

**Step 4 (DIN Bracket only):** Align the mounting holes of the din clip bracket to the three mounting holes on the wall mount bracket.

**Step 5 (DIN Bracket only):** Install the din clips to the wall mount brackets using supplied screws and a Phillips head screwdriver.

**Step 6 (DIN Bracket):** Mount system onto the DIN rail.

*Note: The mounting brackets are required to support 4x the hanging weight of the system. The mating surface and hardware must be capable of supporting the same load.*

## 3.2 - VESA Mounting

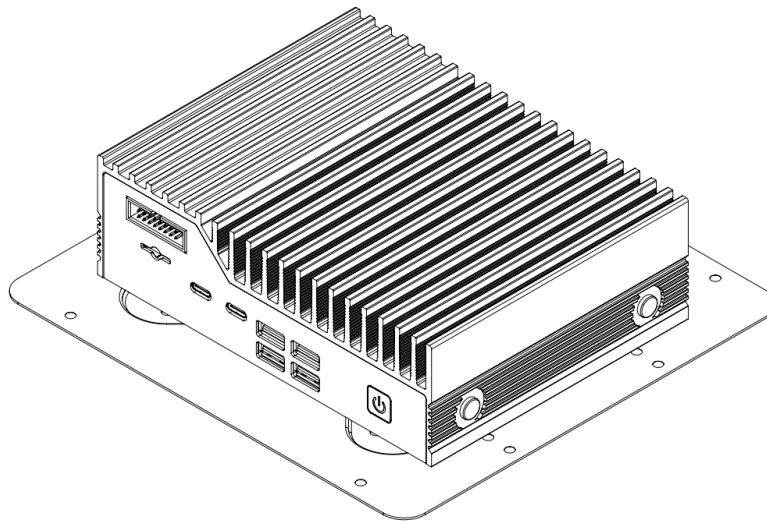

**Step 1:** Align the four screw holes on the bottom of the system with the respective holes on the mounting bracket.

**Step 2:** Attach VESA Mount Plate, to the system using the supplied M3 screws (M3X0.5 Flathead Screw, 4mm Long)

**Step 3:** Install the system to VESA 75 or VESA 100 mounting pattern using provided VESA Mount screws.

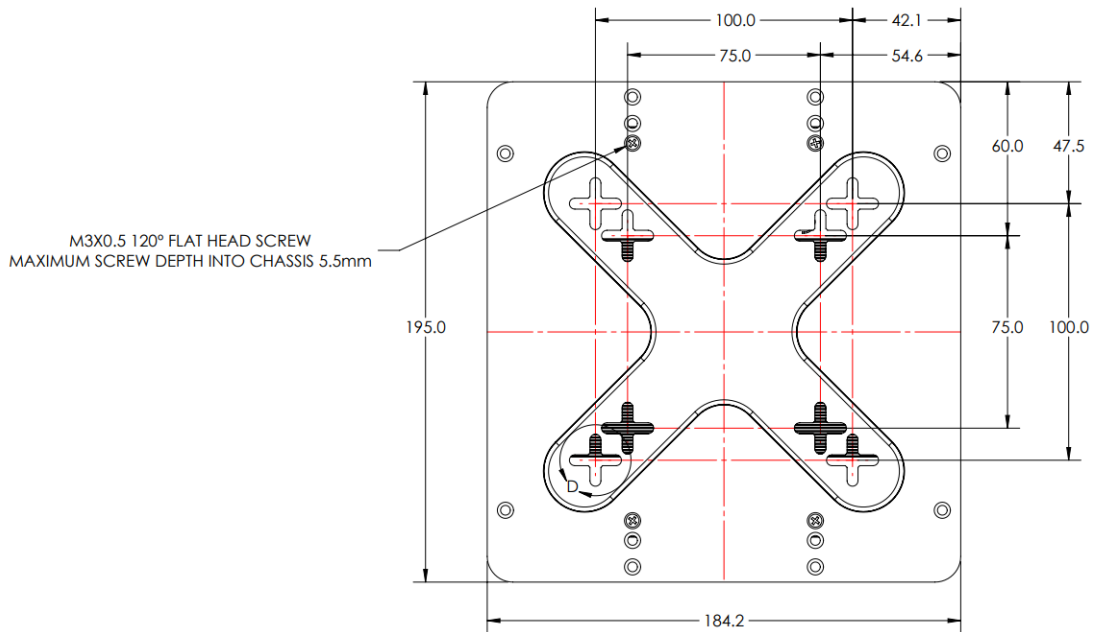

## 4 - Power Management

### 4.1 - Wake-Up Events

The Helix platform supports multiple power states. The wake-up events can be configured in the BIOS. This section describes the supported power management functions and gives information on protection circuitry for power adapters. Low power shutdown is an additional option in the BIOS. See **Appendix C** for more information.

Wake-Up Event	From ACPI State	Comments
Power Button	Low Power shutdown, S5, S3	
LAN	S5, S3	Must be enabled in BIOS
USB	S3	
RTC Wake set by BIOS	S5	Must be enabled in BIOS
RTC Wake set by OS	S3	

## 4.2 - Protection Circuitry

Parameter	Value
<b>Nominal operating voltage (Rated DC value of input)</b>	<b>12~24V (+/-10%)</b>

These DC levels specified are the absolute max values for the pins for function and safety of the system. The protection circuitry allows for brief transient voltages above these levels without the system turning off or being damaged. A transient voltage suppressor on the power input allows momentary excursions above stated limits. For input power consumption and current see **Appendix A**.

## 5 - Regulatory Compliance

### 5.1 - CE

This device has been tested to the relevant EMC and Safety standards. Modifications by the user may invalidate certifications. Testing included EN 55032, EN 55035, EN 60601-1-2, EN 62368-1, and IEC 60945 Ed. 4.

### 5.2 - FCC Statement

This device complies with part 15 of the FCC rules as a Class A device. Operation is subject to the following two conditions: (1) this device may not cause harmful interference and (2) this device must accept any interference received, including interference that may cause undesired operation.

### 5.3 - ISED (Innovation, Science and Economic Development Canada)

This device complies with Industry Canada license-exempt RSS standard(s). Operation is subject to the following two conditions: (1) this device may not cause interference, and (2) this device must accept any interference, including interference that may cause undesired operation of the device.

Le présent appareil est conforme aux CNR d'Industrie Canada applicables aux appareils radio exempts de licence. L'exploitation est autorisée aux deux conditions suivantes : (1) l'appareil ne doit pas produire de brouillage, et (2) l'utilisateur de l'appareil doit accepter tout brouillage radioélectrique subi, même si le brouillage est susceptible d'en compromettre le fonctionnement.

**CAN ICES-003(A) / NMB-003(A)**



## 5.4 - UKCA

The computer system was evaluated for medical, IT equipment, automotive, maritime and railway EMC standards as a class A device. The computer complies with the relevant IT equipment directives for the UKCA mark.

## 5.5 - VCCI

This is a Class A product based on the standard of the Voluntary Control Council for Interference (VCCI). If this equipment is used in a domestic environment, radio interference may occur, in which case the user may be required to take corrective actions.

この装置は、クラス A 情報技術装置です。この装置を家庭環境で使用すると電波妨害を引き起こすことがあります。この場合には使用者が適切な対策を講ずるよう要求されることがあります。 VCCI-A

## 6 - Appendices

### 6.1 - Appendix A: Power consumption

The power consumption of the HX4010 system was measured for various system configurations, workloads, and power states at both 12V and 24V system input voltages. Tests were performed using Burnintest v9.0 build 1012 to stress system components with and without graphics enabled. The build configurations and power consumption are listed in the tables below.

\*The configurations below are using representative samples of internal devices, the specific components mentioned below may vary from the devices provided by OnLogic. The power consumption for each system configuration is record below

System Component	Config 1 Ultra- Low HX401	Config 2 Low HX401	Config 3 Medium HX401	Config 4 High HX401
CPU	Celeron 7305E 5 Core: 1P+4E & 48EU	i3-1220PE 8 Core: 4P+4E & 48EU	i5-1250PE 12 Core: 4P+8E & 80EU	i7-1270PE 12 Core: 4P+8E & 96EU
Memory	8GB DDR5 So-DIMM 1x TS1GSA64V8G Transcend	16GB DDR5 So-DIMM 1x TS2GSA64V8E Transcend	32GB DDR5 So-DIMM 1x TS4GSA64V8E Transcend	64GB DDR5 So-DIMM 2x TS4GSA64V8E Transcend
LAN	1x Intel I219	1x Intel I219	1x Intel I219 1x Intel I210	1x Intel I219 1x Intel I210

Storage #1 M.2 M-Key	Western Digital 500GB Gen4 NVMe SSD	Western Digital 500GB Gen4 NVMe SSD	Western Digital 500GB Gen4 NVMe SSD	Western Digital 500GB Gen4 NVMe SSD
M.2 B-Key	-	-	Samsung 128GB Gen3 NVMe SSD	Samsung 128GB Gen3 NVMe SSD
M.2 E key	-	-	-	Intel 9260
COM1	Idle	Idle	Idle	Idle
CAN	-	-	Plugged-in	Plugged-in
USB	Port 1: N/A Port 2: N/A Port 3: WiFi Dongle Port 4: Wireless Mouse & Keyboard	Port 1: N/A Port 2: N/A Port 3: N/A Port 4: Mouse & Keyboard	Port 1: N/A Port 2: N/A Port 3: WiFi Dongle Port 4: Wireless Mouse & Keyboard	Port 1: N/A Port 2: N/A Port 3: WiFi Dongle Port 4: Wireless Mouse & Keyboard
USB C	Port 1: N/A Port 2: N/A	Port 1: N/A Port 2: N/A	Port 1: USB C Dock Port 2: N/A	Port 1: USB C Dock Port 2: N/A
Display	One Monitor	One Monitor	Two Monitors	Two Monitors
OS	Windows 10 Pro 64 Bit	Windows 10 Pro 64 Bit	Windows 10 Pro 64 Bit	Windows 10 Pro 64 Bit
Power Plan	Balanced	Balanced	Balanced	Balanced
BIOS Version	1.49	1.49	1.49	1.49

<b>Config 1 Ultra-Low HX401</b>		
<b>Power Consumption</b>	<b>12V (avg W)</b>	<b>24V (avg W)</b>
Pseudo G3	0.1	0.1
Deep S5	0.3	0.4
S5	2.4	3.3
S3	2.7	3.6
Windows Idle	5.3	6.2
CPU Stress	16.1	16.4
CPU Stress with graphics	25.2	25.8

<b>Config 2 Low HX401</b>		
<b>Power Consumption</b>	<b>12V (avg W)</b>	<b>24V (avg W)</b>
Pseudo G3	0.1	0.1
Deep S5	0.3	0.4
S5	2.4	3.3
S3	2.7	3.6
Windows Idle	5.5	6.3
CPU Stress	48.9	49.4
CPU Stress with graphics	47.6	47.8

<b>Config 3 Med HX401</b>		
<b>Power Consumption</b>	<b>12V (avg W)</b>	<b>24V (avg W)</b>
Pseudo G3	0.1	0.1
Deep S5	0.4	0.7
S5	2.3	3.1
S3	3.2	4.0
Windows Idle	8.6	10.1
CPU Stress	46.1	47.0
CPU Stress with graphics	51.2	53.4

<b>Config 4 High HX401</b>		
<b>Power Consumption</b>	<b>12V (avg W)</b>	<b>24V (avg W)</b>
Pseudo G3	0.1	0.1
Deep S5	0.3	0.4
S5	2.5	3.4
S3	4.2	4.9
Windows Idle	9.3	10.7
CPU Stress	46.3	47.1
CPU Stress with graphics	53.6	57.3

## 6.2 - Appendix B: Isolated DIO guide

Additional information for the Isolated DIO can be found on the OnLogic support site. Please refer to the link below for additional information.

[ADP102 / ADP120 Isolated DIO module - OnLogic Support](#)

## 6.3 - Appendix C: BIOS manual

For a detailed overview of the BIOS screens and individual settings, please refer to the OnLogic support site. Instructions for updating the BIOS can also be found on the support site. Please refer to the link below for detailed instructions.

<https://static.onlogic.com/resources/manuals/OnLogic-HX401-BIOS-Manual-1.49-v1.pdf>

## 6.4 - Appendix D: CAN user guide

Additional information for using the on-board CAN transceiver can be found on the OnLogic support site. Please refer to the link below for additional information.

<https://www.onlogic.com/support/documentation/hx400-technical-resources>

## 6.5 - Appendix E: System thermal results

### 6.5.1 Test Conditions

- Temperature Range: 0°C to 50°C
- Step size: 10°C
- i7 Processor, 1TB PCIe Gen3 x4 SSD, and 64GB RAM loaded @ 80% with BurnInTest 9.2

## 6.5.2 Test Results

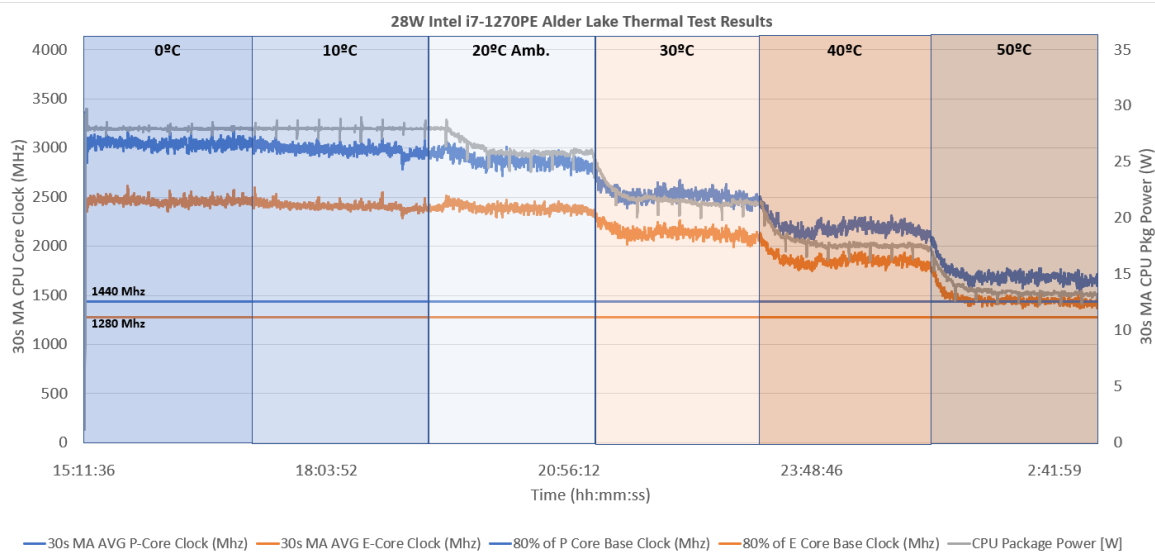

## 6.5.3 Test Result Summary

The HX401 with i7-1270PE operated upwards of 80% of its rated base clock speeds on performance and efficiency cores while sustaining significant processor, memory and storage stress loads in an ambient temperature of 50°C.

## 6.6 - Appendix F: Expansion port pinout

### 6.6.1 - M.2 B-Key

Pin	Function	Function	Pin
1	CONFIG_3	3.3V	2
3	GND	3.3V	4
5	GND	FULL_CARD_POWER_OFF#	6
7	USB 2.0 D+	W_DISABLE1#	8
9	USB 2.0 D-	NC	10
11	GND	KEY	
	KEY	KEY	
	KEY	KEY	
	KEY	KEY	
	KEY	NC	20
21	CONFIG_0	NC	22

23	NC	NC	24
25	NC	GPIO_10/W_DISABLE2#	26
27	GND	NC	28
29	PERn1/USB3.1-Rx-	UIM-RESET	30
31	PERp1/USB3.1-Rx+	UIM_CLK	32
33	GND	UIM_DATA	34
35	PETn1/USB3.1-Tx-	UIM_PWR	36
37	PETp1/USB3.1-Tx+	NC	38
39	GND	NC	40
41	PERn0/SATA-B+	NC	42
43	PERp0/SATA-B-	NC	44
45	GND	NC	46
47	PETn0/SATA-A-	NC	48
49	PETp0/SATA-A+	PERST#	50
51	GND	CLKREQ#	52
53	REFCLKn	PEWAKE#	54
55	REFCLKp	NC	56
57	GND	NC	58
59	NC	NC	60
61	NC	NC	62
63	NC	NC	64
65	NC	SIM_DETECT	66
67	RESET_N	SUSCLK	68
69	CONFIG_1	3.3V	70
71	GND	3.3V	72
73	GND	3.3V	74
75	CONFIG_2		

### 6.6.2 - M.2 E-Key

Pin	Function	Function	Pin
1	GND	3.3 V	2
3	USB_D+	3.3 V	4
5	USB_D-	NC	6
7	GND	NC	8

9	RESERVED	NC	10
11	RESERVED	NC	12
13	RESERVED	NC	14
15	RESERVED	NC	16
17	RESERVED	GND	18
19	RESERVED	NC	20
21	RESERVED	NC	22
23	RESERVED	KEY	
	KEY	KEY	
	KEY	KEY	
	KEY	KEY	
	KEY	RESERVED	32
33	GND	RESERVED	34
35	PETp0	RESERVED	36
37	PETn0	RESERVED	38
39	GND	RESERVED	40
41	PERp0	RESERVED	42
43	PERn0	RESERVED	44
45	GND	RESERVED	46
47	REFCLKp0	RESERVED	48
49	REFCLKn0	SUSCLK(32kHz)	50
51	GND	PERST0#	52
53	CLKREQ0#	W_DISABLE2#	54
55	PEWAKE0#	W_DISABLE1#	56
57	GND	NC	58
59	RESERVED	NC	60
61	RESERVED	NC	62
63	GND	RESERVED	64
65	RESERVED	NC	66
67	RESERVED	NC	68
69	GND	NC	70
71	RESERVED	3.3V	72
73	RESERVED	3.3V	74
75	GND		

### 6.6.3 - M.2 M-Key

Pin	Function	Function	Pin
1	GND	3.3 V	2
3	GND	3.3 V	4
5	PERn3	NC	6
7	PERp3	NC	8
9	GND	NC	10
11	PETn3	3.3 V	12
13	PETp3	3.3 V	14
15	GND	3.3 V	16
17	PERn2	3.3 V	18
19	PERp2	NC	20
21	GND	NC	22
23	PETn2	NC	24
25	PETp2	NC	26
27	GND	NC	28
29	PERn1	NC	30
31	PERp1	NC	32
33	GND	NC	34
35	PETn1	NC	36
37	PETp1	NC	38
39	GND	NC	40
41	PERn0/SATA-B+	NC	42
43	PERp0/SATA-B-	NC	44
45	GND	NC	46
47	PETn0/SATA-A-	NC	48
49	PETp0/SATA-A+	PERST# (O)(0/3.3V) or NC	50
51	GND	CLKREQ# (I/O)(0/3.3V) or NC	52
53	REFCLKn	PEWAKE# (I/O)(0/3.3V) or NC	54
55	REFCLKp	NC	56
57	GND	NC	58
	CONNECTOR Key M	CONNECTOR Key M	
	CONNECTOR Key M	CONNECTOR Key M	
	CONNECTOR Key M	CONNECTOR Key M	



	CONNECTOR Key M	CONNECTOR Key M	
67	NC	SUSCLK(32kHz) (O)(0/3.3V)	68
69	PEDET (NC-PCIe/GND-SATA)	3.3 V	70
71	GND	3.3 V	72
73	GND	3.3 V	74
75	GND		