

# MC510-55/MC610-55 Manual

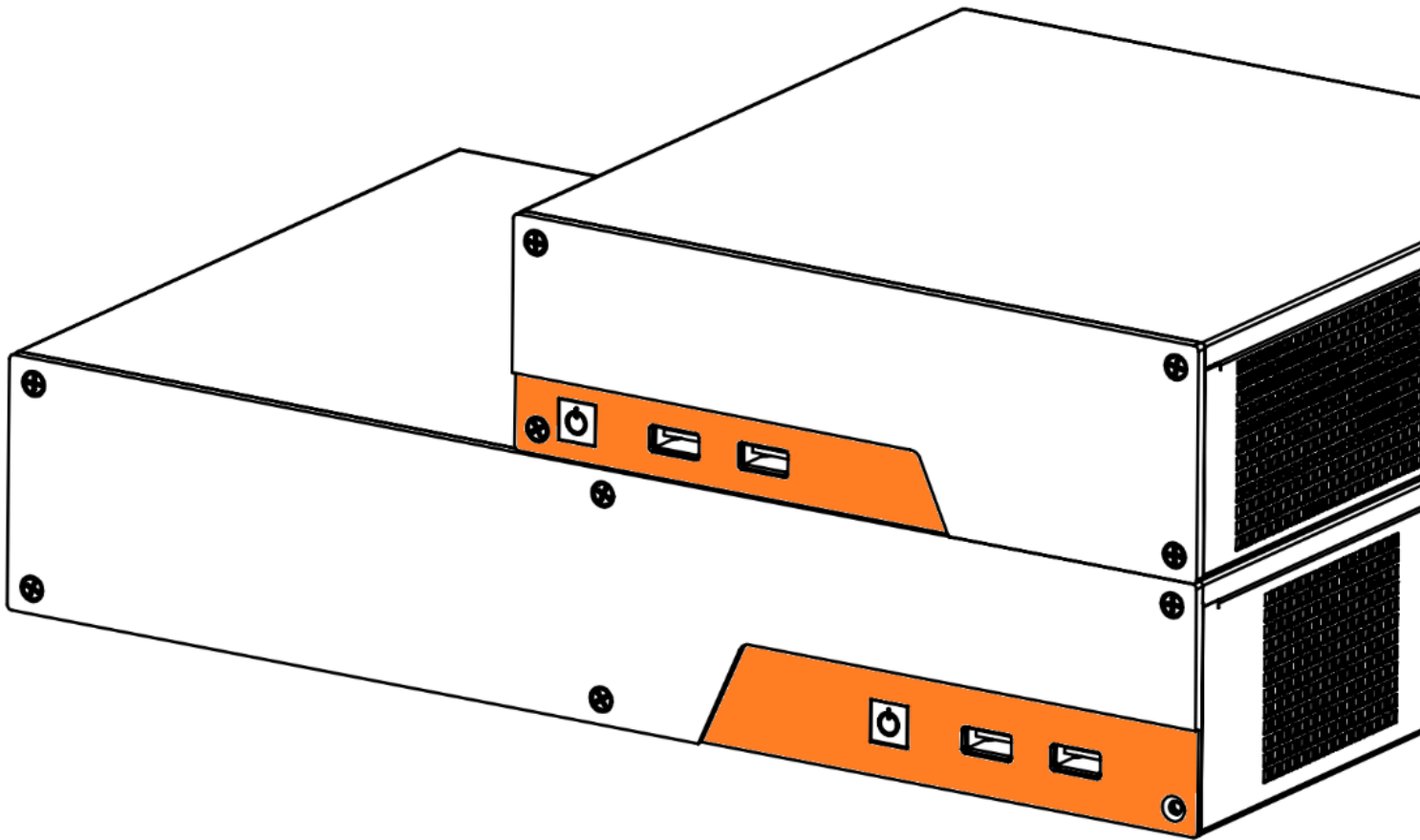

# Revision History

Revision History	Date

## Table of Contents

<b>1 - System Overview</b>	<b>4</b>
1.1 System Introduction	4
1.2- In-box Accessories	4
1.3 - Product Specifications	5
1.4 - Exterior Features and Dimensions	8
1.4.1 - Front I/O - MC510-55	8
1.4.2 - Back I/O - MC510-55	8
1.4.3 - Front I/O - MC610-55	9
1.4.4 - Back I/O - MC610-55	9
1.4.5 - MC510-55 Dimensions	9
1.4.6 - MC610-55 Dimensions	10
1.5 - System Block Diagram	12
<b>2 - I/O Definitions</b>	<b>13</b>
2.1 - Front I/O definition	13
2.2 - Rear I/O definition	14
2.3 - Motherboard Connectors	17
<b>3 - Mounting Instructions</b>	<b>19</b>
3.1 - Wall Mount & DIN Rail Mounting	19
3.2 - VESA Mounting	20
<b>4 - Power Management</b>	<b>21</b>
4.1 - Wake-Up Events	21
4.2 - Protection Circuitry	21
<b>5. Appendices</b>	<b>22</b>
5.1 - Appendix A: Power consumption	22
5.3 - Appendix B: BIOS manual and Drivers	24
5.4 - Appendix C: System Thermal Results	24
5.4.1 Test Conditions	24
5.4.2 Test Methodology	24

5.4.3 Test Results	25
5.4.4 Test Result Summary	25
5.5 Appendix E: Regulatory Compliance	25
5.5.1 CE	25
5.5.2 FCC Statement	26
5.5.3 ISED	26
5.5.4 UKCA	26
5.5.5 VCCI	26
5.6 Appendix F: Safety Precautions, Safeguards & Information	26
5.6.1 Safe use and installation instructions	26
5.6.2 Précautions et guide d'installation	28
5.7 Appendix G: Errata	30

# 1 - System Overview

## 1.1 System Introduction

The MC510-55 and MC610-55 deliver reliable industrial computing using Intel® 12th Generation, or 13th Generation performance hybrid processing.

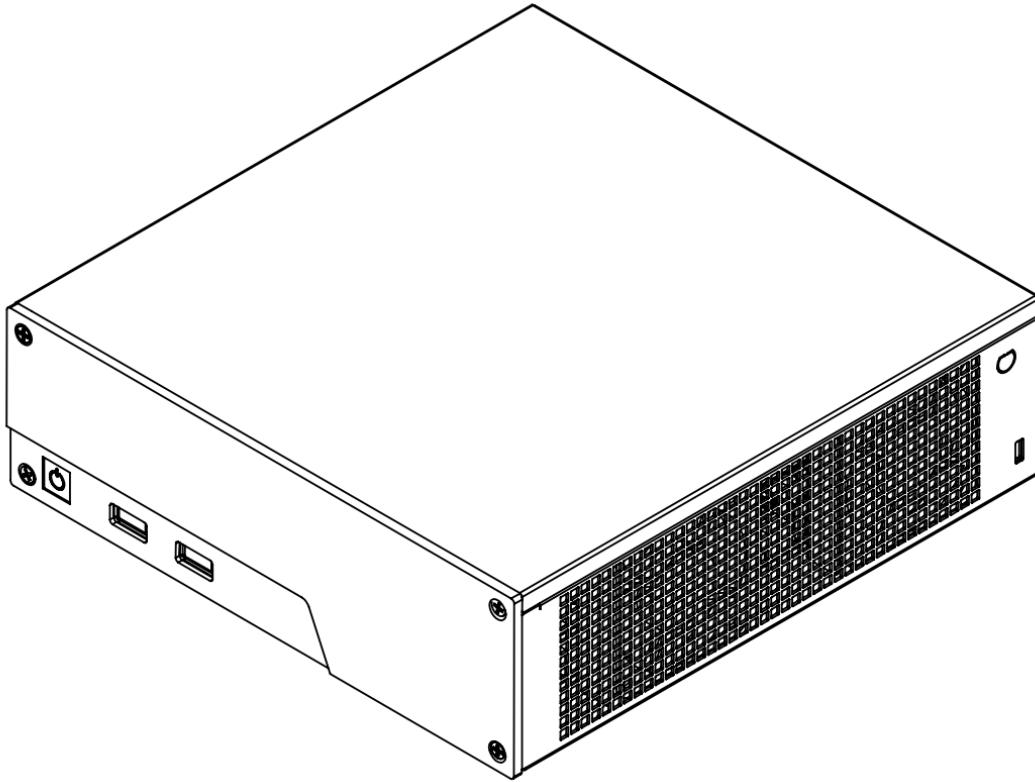

The system is ideal for real-time decision making in automation applications, with support for up to four simultaneous serial connections.

## 1.2- In-box Accessories

- 4x Rubber Feet
- Power cable retention - MC510-55 only
- Power Supply
- Extra Screws







If you purchased additional items such as mounting brackets, power supplies or terminal block connectors, they will be located in the system box or within the outer shipping carton.

All drivers and product guides can be found on the corresponding product page. For more information on accessories and additional features, visit the MC510-55 or MC610-55 product page:

- <https://www.onlogic.com/mc510-55/>
- <https://www.onlogic.com/mc610-55/>

## 1.3 - Product Specifications

Model	MC510-55	MC610-55
<b>System Dimensions</b>	155.2mm x 162.5mm x 48.5mm	162mm x 271.6mm x 52mm
<b>System Weight</b>	6.2lbs	9.8lbs
<b>Board Dimensions</b>	6.7" x 6.7" 170 mm x 170 mm	
<b>CPU</b>	Socket LGA 1700 - Raptor/Alder Lake S	
<b>PCH</b>	Intel H610	
<b>Memory</b>	2 x SO-DIMM DDR4 (2 x 32GB max Dual Channel) 64 GB Total	
<b>LAN Controller</b>	2x Intel i225-LM/i225V (vPro not supported)	
<b>Expansion</b>	1 x M.2 (Key M, 2242/2260/2280) with PCIe Gen3 x4 for SSD 1 x M.2 (Key E, 2230) with PCIe x1, USB 2.0 and CNVi for Wireless 1 x M.2 (Key B, 3042/3052) with PCIe x1, USB 3.2 Gen1, USB 2.0 and SIM for 4G/5G	1 x M.2 (Key M, 2242/2260/2280) with PCIe Gen3 x4 for SSD 1 x M.2 (Key E, 2230) with PCIe x1, USB 2.0 and CNVi for Wireless 1 x M.2 (Key B, 3042/3052) with PCIe x1, USB 3.2 Gen1, USB 2.0 and SIM for 4G/5G 1 x PCIe x16 (Gen4)
<b>Back I/O</b>	2x Full size DisplayPort 1.4a++ 1x HDMI 2.0b 2x 2.5Gb LAN (2 x Intel) 2x USB 3.2 (Gen2) 2x USB 2.0 2x Audio (Mic-in, Line-out) Optional 4x COM (2x RS-232/422/485, 2x RS-232) DC-In	2x Full size DisplayPort 1.4a++ 1x HDMI 2.0b 2x 2.5Gb LAN (2 x Intel) 2x USB 3.2 (Gen2) 2x USB 2.0 2x Audio (Mic-in, Line-out) Optional 3x COM (2x RS-232/422/485, 1x RS-232) DC-In
<b>Front I/O</b>	1x Power button with LED indicator 2x USB 2.0	
<b>Onboard Headers &amp; Connectors</b>	1x Battery on a cable 1x LVDS Panel Connector - eDP Connector (on the Backside of PCB)	
<b>aVoltage Input</b>	12~28V	12~28V

<b>Power Input</b>	DC Jack(Screw type)	4-pin terminal block
<b>BIOS</b>	AMI SPI 256 Mbit	AMI SPI 256 Mbit
<b>Operating Systems</b>	Windows 10 IOT 2021 LTSC, Windows 10 IOT 2019 LTSC, Ubuntu 22.04 LTS, Window 11	Windows 10 IOT 2021 LTSC, Windows 10 IOT 2019 LTSC, Ubuntu 22.04 LTS, Window 11
<b>Special Features</b>	Watchdog Timer PTT in BIOS On-board TPM 2.0 Support for 4G LTE and GPS expansion cards	Watchdog timer PTT in BIOS On-board TPM 2.0 Support for 4G LTE and GPS expansion cards
<b>Thermal Standards (Subject to change through RFI and RFQ steps)</b>	System Operating Temperature: 0-50C Storage Temperature: -10-70C Operating Humidity: 0% - 90% (non-condensing)	System Operating Temperature: 0-50C Storage Temperature: -10-70C Operating Humidity: 0% - 90% (non-condensing)
<b>Extra Chassis Features</b>	6 Antenna holes Wall Mount DIN Rail Mount VESA Mount	8 Antenna holes Wall Mount DIN Rail Mount VESA Mount
<b>Regulatory Certifications</b>	 FCC 47 CFR Part 15 Subpart B (Class A)  EN 63268-1 CISPR 32/EN 55032 CISPR 35/EN 55035 Radio Equipment Directive (2014/53/EU)  WEEE Directive (2012/19/EU)  RoHS 3 (2015/863/EU)  IEC 60601-1-2, 4th ed. - EMC Ready  IEC/UL/EN 62368-1	

<b>Radio Specifications when equipped with Intel AC 9260 Wi-Fi (device for indoor use)</b>	
<b>Frequency Bands</b>	2.4 GHz and 5 GHz bands
<b>Operating Frequency</b>	2400 - 2485 MHz 5150 - 5250 MHz, 5250 - 5350 MHz 5470 - 5725 MHz, 5725 - 5878 MHz
<b>Channel Spacing / Bandwidth</b>	2.4GHz: 802.11b/g/n; 5 MHz / BT: 1MHz Bandwidth: 20 MHz / 40 MHz

	5 GHz: 802.11a/n/ac: 20, 40, 80, 160 MHz
<b>RF Output Power</b>	20 dBm (2400-2485 MHz) IEEE 802.11b/g/n & BT 10 dBm (2400-2485 MHz) BLE 23 dBm (5150-5725 MHz) IEEE 802.11a/n/ac 13.98 dBm (5725-5875 MHz) IEEE 802.11a/n/ac
<b>Type of Modulation</b>	2.4 GHz: DSSS/OFDM/FHSS 5 GHz: OFDM
<b>Type of Antenna</b>	Reference antenna is PIFA type (2 dBi/2 dBi gain)
<b>Modes of Operation</b>	Duplex (Tx/Rx)
<b>Duty Cycle (Access Protocol)</b>	As In: IEEE 802.11a/b/g/n/ac

<b>Radio specifications when equipped with Amit MDG100 (EU)</b>	
<b>GPS Receiver</b>	Operating frequency range: 1559 - 1610 MHz
<b>GLONASS Receiver</b>	Operating frequency range: 1559 - 1610 MHz
<b>BDS Receiver</b>	Operating frequency range: 1559 - 1610 MHz
<b>Galileo Receiver</b>	Operating frequency range: 1559 - 1610 MHz
<b>QZSS Receiver</b>	Operating frequency range: 1559 - 1610 MHz
<b>GSM 900</b>	Operating frequency range: 880 - 915 MHz, 925 - 960 MHz Maximum output power: 33dBm rated
<b>GSM 1800</b>	Operating frequency range: 1710 - 1785 MHz, 1805 - 1880 MHz Maximum output power: 30dBm rated
<b>WCDMA Band 1</b>	Operating frequency range: 1920 - 1980 MHz, 2110 - 2170 MHz Maximum output power: 24dBm rated
<b>WCDMA Band 8</b>	Operating frequency range: 880 - 915 MHz, 925 - 960 MHz Maximum output power: 24dBm rated
<b>LTE FDD Band 1</b>	Operating frequency range: 1920 - 1980 MHz, 2110 - 2170 MHz Maximum output power: 23dBm rated
<b>LTE FDD Band 3</b>	Operating frequency range: 1710 - 1785 MHz, 1805 - 1880 MHz Maximum output power: 23dBm rated
<b>LTE FDD Band 7</b>	Operating frequency range: 2500 - 2570 MHz, 2620 - 2690 MHz Maximum output power: 23dBm rated
<b>LTE FDD Band 8</b>	Operating frequency range: 880 - 915 MHz, 925 - 960 MHz Maximum output power: 23dBm rated
<b>LTE FDD Band 20</b>	Operating frequency range: 832 - 862 MHz, 791 - 821 MHz Maximum output power: 23dBm rated
<b>LTE FDD Band 28A</b>	Operating frequency range: 703 - 733 MHz, 758 - 788 MHz Maximum output power: 23dBm rated

<b>LTE FDD Band 38</b>	Operating frequency range: 2570 - 2620 MHz Maximum output power: 23dBm rated
<b>LTE FDD Band 40</b>	Operating frequency range: 2300 - 2400 MHz Maximum output power: 23dBm rated
<b>E-GSM</b>	Operating frequency range: 880 - 915 MHz Maximum output power: 33dBm rated
<b>DCS</b>	Operating frequency range: 1710 - 1785 MHz Maximum output power: 30dBm rated

## 1.4 - Exterior Features and Dimensions

### 1.4.1 - Front I/O - MC510-55

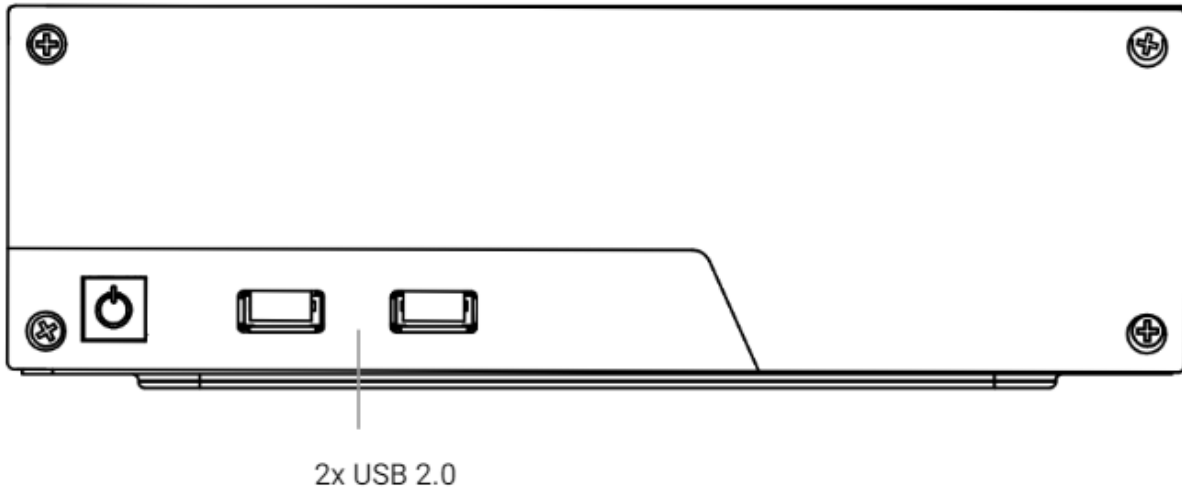



### 1.4.2 - Back I/O - MC510-55

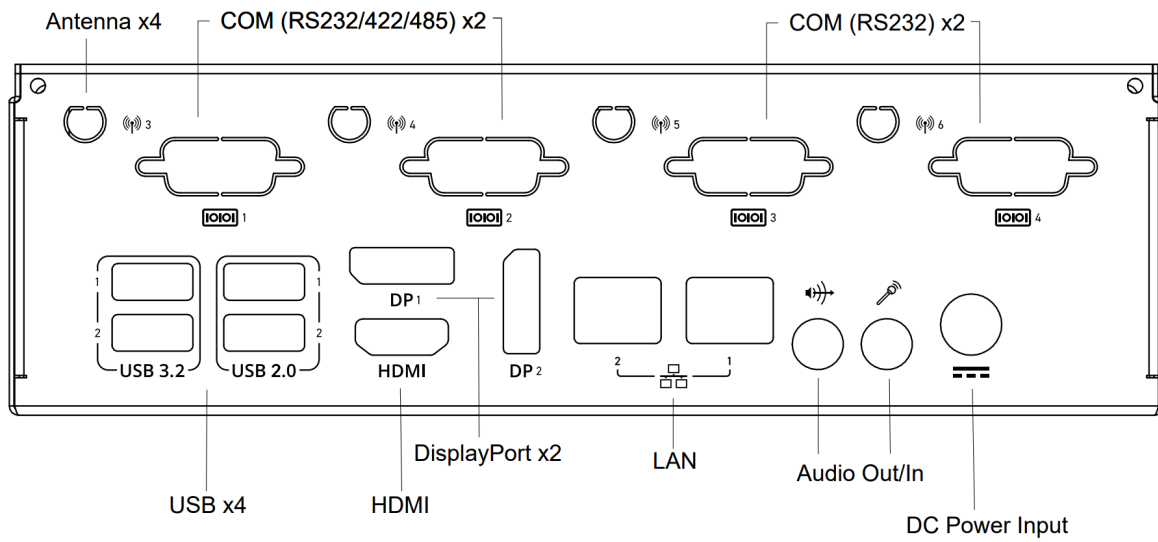

### 1.4.3 - Front I/O - MC610-55

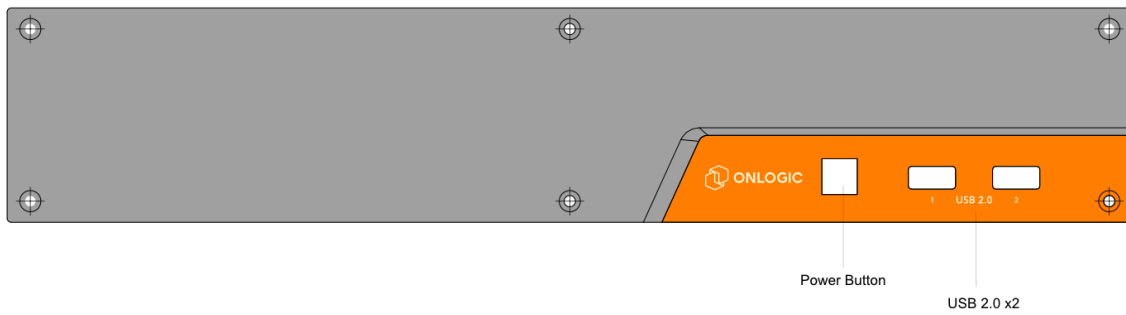

### 1.4.4 - Back I/O - MC610-55

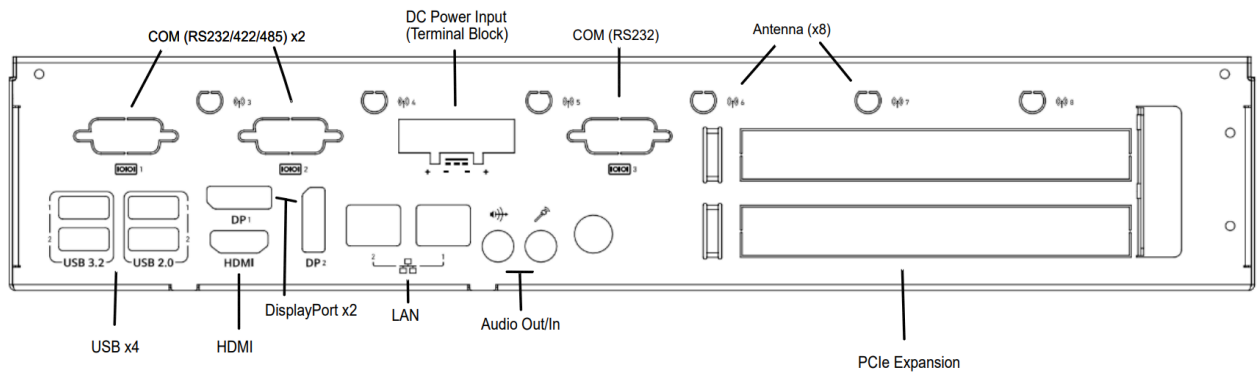

### 1.4.5 - MC510-55 Dimensions

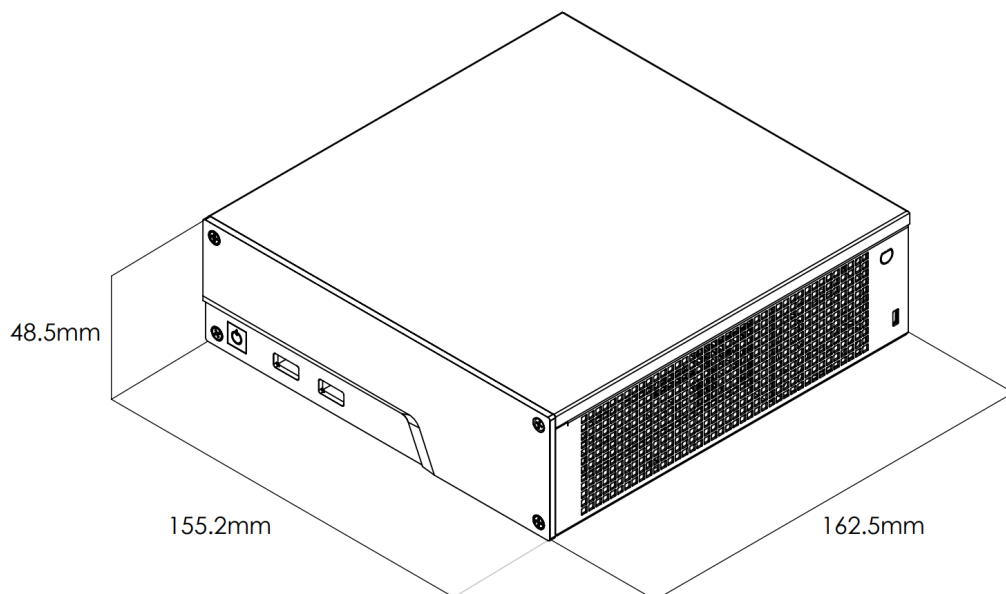

### 1.4.6 - MC610-55 Dimensions

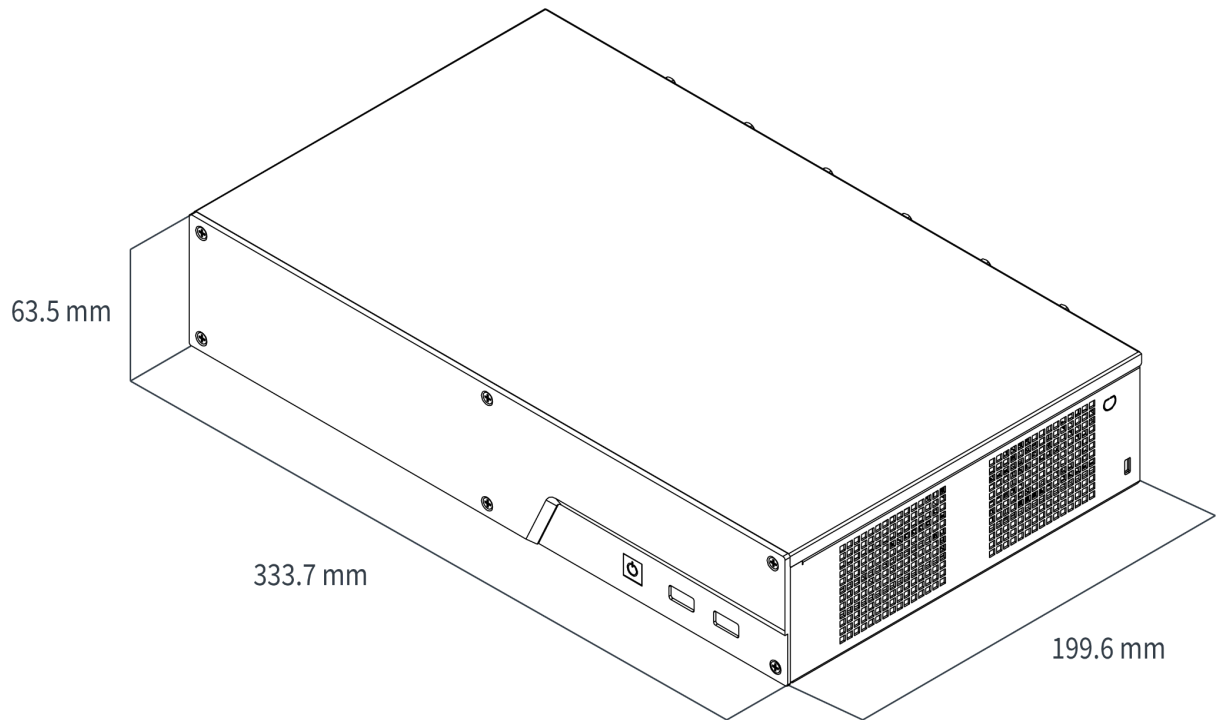

# 1.5 - System Block Diagram

## Color Key

Signal Colors	Connector Colors
Red - PCIe	Orange - External
Brown - SATA	Blue - Internal
Blue - USB	
Yellow - UART	
Grey - Misc	

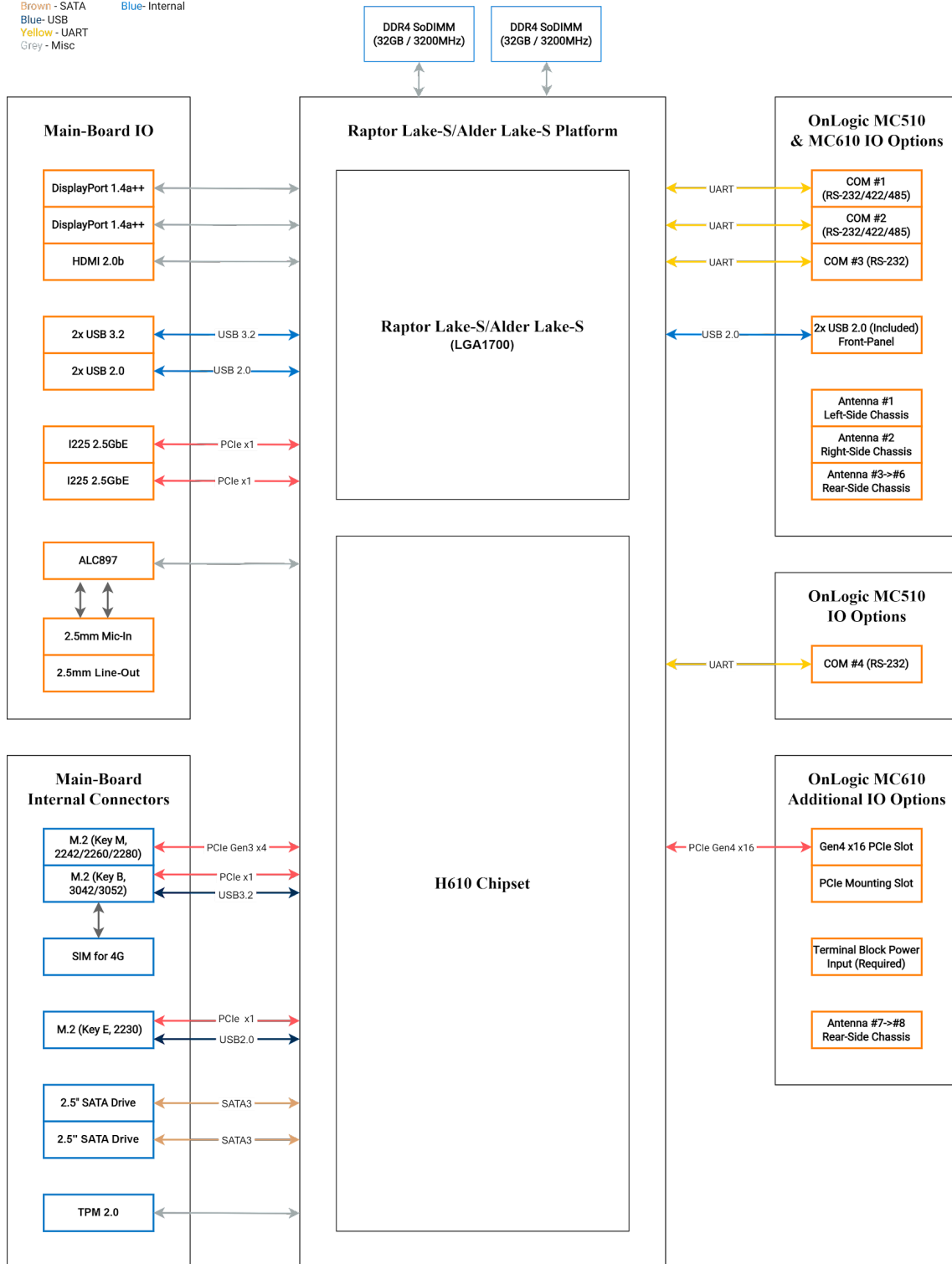

## 2 - I/O Definitions

### 2.1 - Front I/O Definition

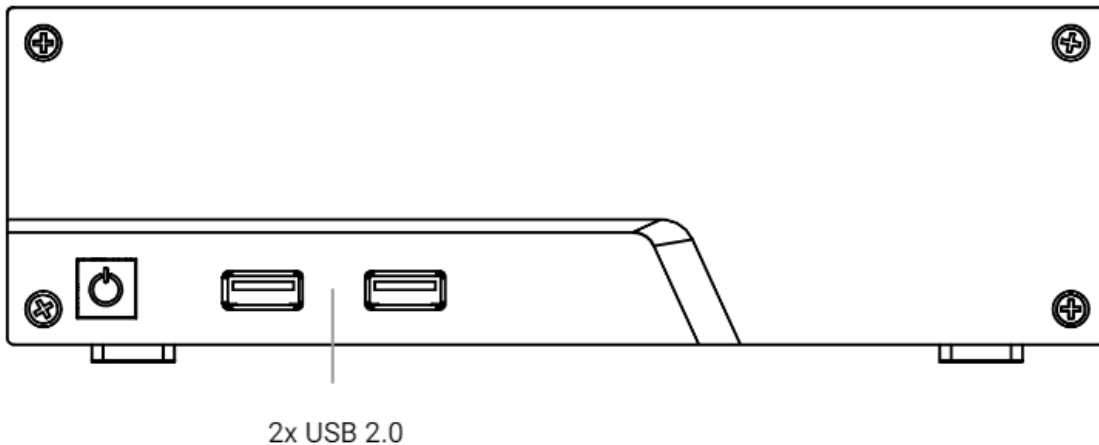

#### Power Button / Power LED

The front power button can be used to turn on and off the system. The power button is a momentary contact button with a blue LED backlight used to display the status of the system. A single press while the system is on will initiate a graceful shutdown operation from the OS. Pressing and holding the button for 4 seconds while the system is running will cause a hard reset of the system. The system can be woken by a single press of the power button from any state.

The LED backlight will indicate the system status. A solid blue light indicates that the system is powered in the S0 state. A flashing blue light indicates the system is in the sleep state. The LED is off in S5 and deep sleep states.

#### USB 2.0

There are two USB 2.0 ports on the front panel of the system. These ports are capable of linking at 0.48Gb/s transfer rates.

## 2.2 Rear I/O Definition

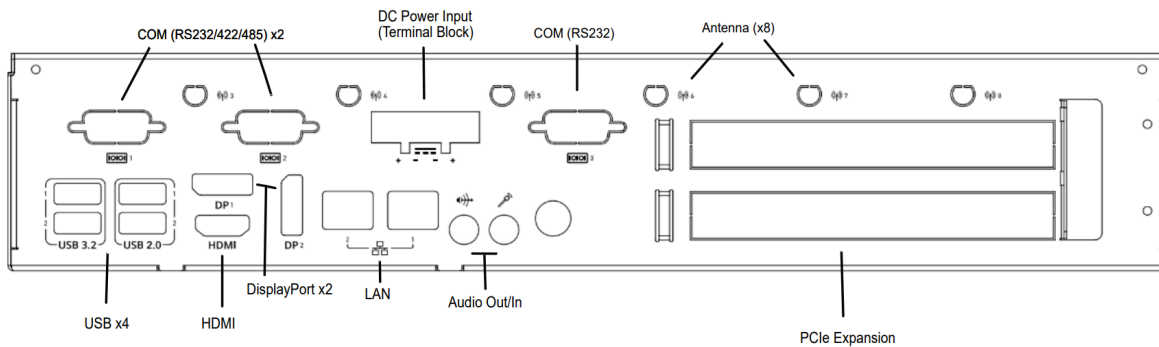
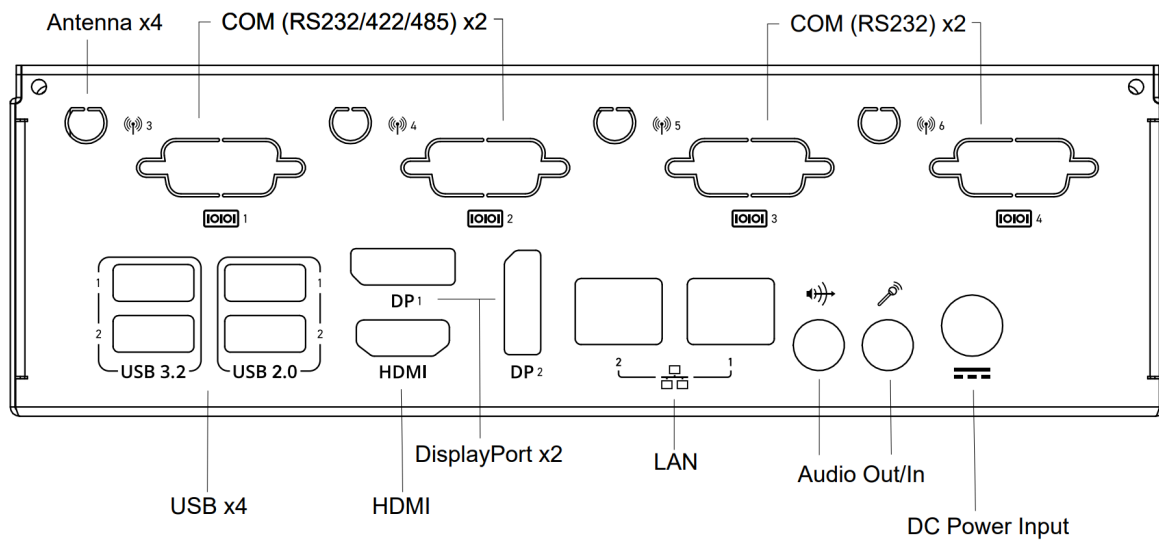

### DisplayPort 1 & 2

The MC510-55/MC610-55 utilizes Intel® Integrated processor graphics that power the onboard DisplayPorts. This means resolutions up to 4096x2304 @ 60Hz are supported on both outputs simultaneously. All ports support Multi-Stream Transport (MST).

### HDMI Port

There is one HDMI 2.0b located on the system that can support resolutions up to 4096x2304 @ 60Hz.

### LAN1/LAN2 - Intel I225-LM

The Intel I225 LAN Port supports up to 2.5Gbps link speeds over standard shielded CAT5e or CAT6 cables. The connector is the industry standard RJ45 connector. The H610 chipset in this system does

not support AMT/VPro regardless of the SKU of the onboard NIC. The LAN link state is shown by the two LEDs enclosed in the port. The description is included below.

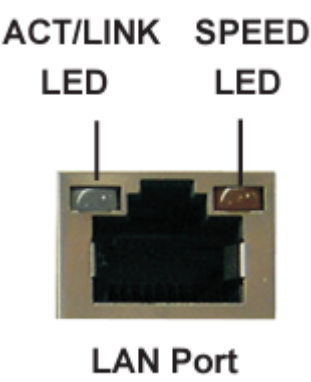
	LED	Color	State	Function
	Link	-	Off	LAN link is not established
		Green	On	LAN link is established
			Blinking	LAN activity occurring
Speed	-	Off	10 Mb/s data rate	
	Orange	On	100 Mb/s / 1 Gb/s data rate	
	Green	On	2.5 Gb/s data rate	

LAN activity light description

## USB 3.2

The dual stack USB 3.2 ports on the rear panel are USB 3.2 Gen 2 ports, capable of linking at 10Gb/s transfer rates.

## USB 2.0

There are two USB 2.0 ports on the rear panel of the system. These ports are capable of linking at 0.48Gb/s transfer rates.

## Audio (Line out / Microphone)

Using Realtek ALC897 the system can provide high-performance multi-channel High Definition Audio Codec with Realtek proprietary lossless content protection technology that protects pre-recorded content while still allowing full-rate audio enjoyment.

## COM DB9 option

The serial ports support RS-232, RS-422, and RS-485 configurations depending on the COM port used. Refer to the BIOS manual in Appendix C for configuration instructions.

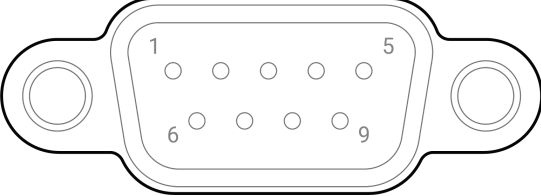
	Pin	RS-232	RS-422	RS-485
	1	DCD	TX-	TX-/RX-
	2	RX	TX+	TX+/RX+
	3	TX	RX+	NC
	4	DTR	RX-	NC
	5	GND	NC	NC
	6	DSR	NC	NC
	7	RTS	NC	NC
	8	CTS	NC	NC
9	RI/PWR	NC/PWR	NC/PWR	

COM DB9 pinout

### Terminal block power option

For the MC610, a terminal block is used in place of the barrel-jack to provide 24V capability up to 330W (Mating part: Dinkle 2ESDAM-04P or equivalent).

The system is operational from 12V~24V. The maximum rated current of the connector is 15A per pin. Use a wire gauge that is rated for the operational current. Cables should be properly terminated with wire ferrules. Do not use the terminal block with tinned wire ends or solid core wire. See below for connector pinout.

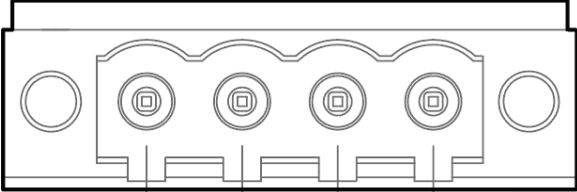
	Pin	Function
	1	DC +
	2	DC -
	3	DC -
4	DC +	

Terminal block power pinout



## 2.3 - Motherboard Connectors

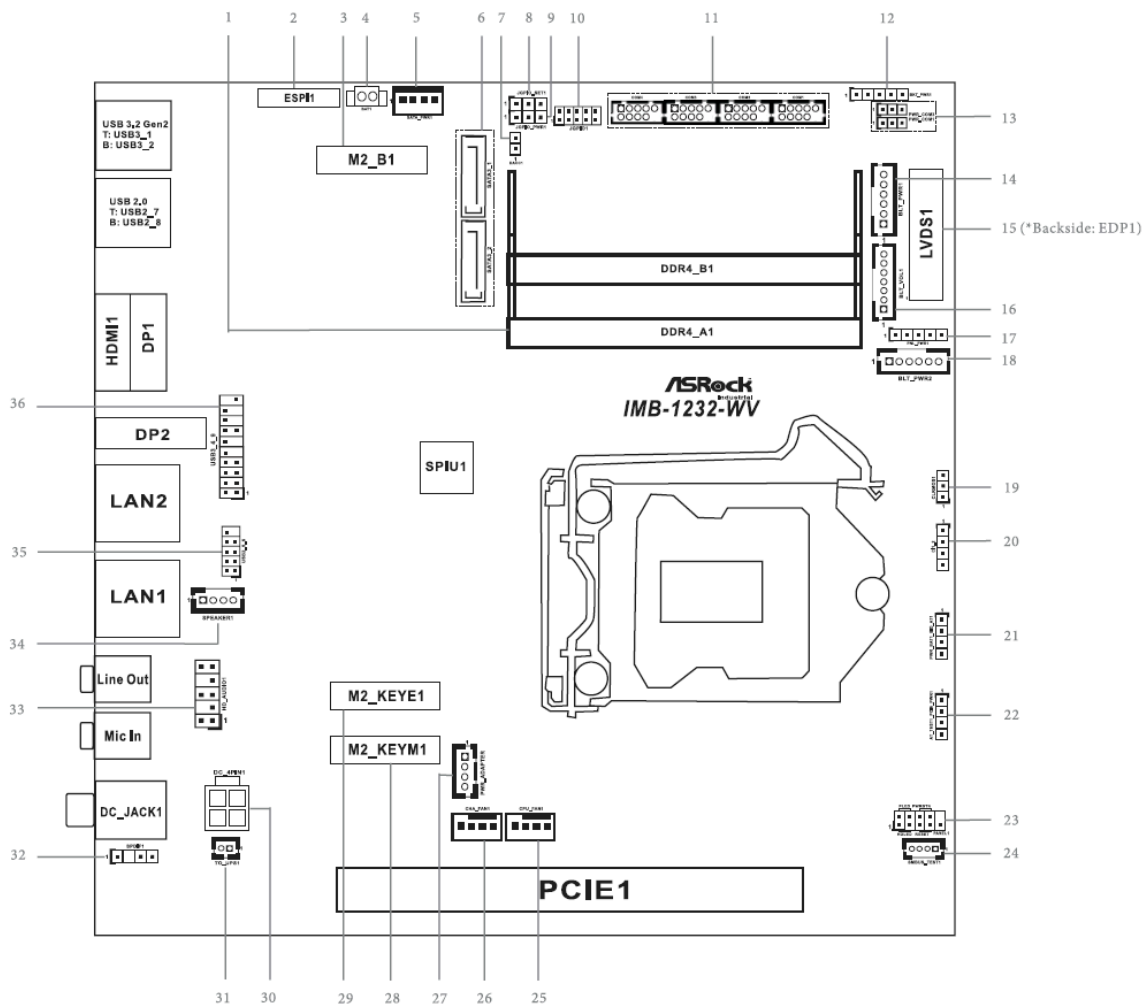

1 : DDR4 SO-DIMM Sockets	18 : Inverter Power Control Wafer (BLT_PWR2)
2 : ESPI Header (ESPI1)	19 : Clear CMOS Header (CLRMOSt1)
3 : M.2 Key-B Socket (M2_B1)	20 : Chassis Intrusion Header (CI1_2)
4 : Battery Connector	21 : PWR_BAT1_SIO_AT1
5 : SATA Power Output Connector	22 : AT_TEST1_PCIE_PWR1
6 : SATA3 Connectors (SATA3_1, SATA3_2)	23 : System Panel Header
7 : DACC1	24 : SMBUS_TEST1
8 : Digital Input / Output Default Value Setting (JGPIO_SET1)	25 : CPU FAN Connector (+12V)
9 : Digital Input / Output Power Select (JGPIO_PWR1)	26 : Chassis FAN Connector (+12V)
10 : Digital Input/Output Pin Header (JGPIO1)	27 : Power Adapter
11 : COM Port Headers (COM1, 2, 3, 4)	28 : M.2 Key-M Socket (M2_KEYM1)
12 : Backlight Power Select (LCD_BLT_VCC) (BKT_PWR1)	29 : M.2 Key-E Socket (M2_KEYE1)
13 : COM Port PWR Setting Jumpers PWR_COM3 (For COM Port3) PWR_COM1 (For COM Port1)	30 : 4-pin ATX PWR Connector
14 : Inverter Power Control Wafer (BLT_PWR1)	31 : 2-pin UPS Module Power Input Connector
	32 : SPDIF Header
	33 : Front Panel Audio Header
	34 : 3W Audio AMP Output Wafer
	35 : USB2.0 Header (USB2_5_6)
	36 : USB3.2 Gen1 Header (USB3_4_9)

15 : LVDS Panel Connector* * eDP Connector (on the Backside of PCB) 16 : Backlight Volume Control (BLT_VOL1) 17 : Panel Power Select (LCD_VCC) (PNL_PWR1)	Back Side : SIM Card Socket (SIM1)eDP Connector (EDP1, refer to No. 15)
---	---

## M.2 B-Key

An M.2 B-Key port is present on the motherboard to allow support for B-Key form-factor expansion cards. Supported cards include 3042 and 3052 form-factors. The B-Key connector supports PCIe x1, USB 3.2 10Gb/s, and USB 2.0 devices.

The 3FF Micro SIM card slot is connected to the M.2 B-Key.

## M.2 E-Key

An M.2 E-Key port is present on the motherboard to allow support for E-Key form-factor wireless expansion cards. Only 2230 form-factor cards are supported. The E-Key connector supports PCIe x1, CNVi for wireless, and USB 2.0.

## M.2 M-Key

An M.2 M-Key port is present on the motherboard to allow support for M-Key form-factor expansion cards. 2242, 2260, and 2280 form-factor cards are supported. The M-Key connector includes support for PCIe Gen 3 x4 devices.

## SO-DIMM1 & SO-DIMM2

The motherboard has two onboard DDR4 SO-DIMM slots with the following specifications:

- Maximum Capacity: DDR4-2300 64GB with two 32GB SO-DIMM Modules
- Channel configuration: 1 DIMM Per Channel (DPC) - 2 Channels
- No ECC Support

## BIOS EEPROM

If the BIOS needs to be updated, please refer to **Appendix B** for the document instructing reflashing instructions.

## CPU socket

The LGA1700 CPU socket on the motherboard supports all 12th and 13th Gen Intel series processors up to 35W base TDP.

## 3 - Mounting Instructions

### 3.1 - Wall Mount & DIN Rail Mounting

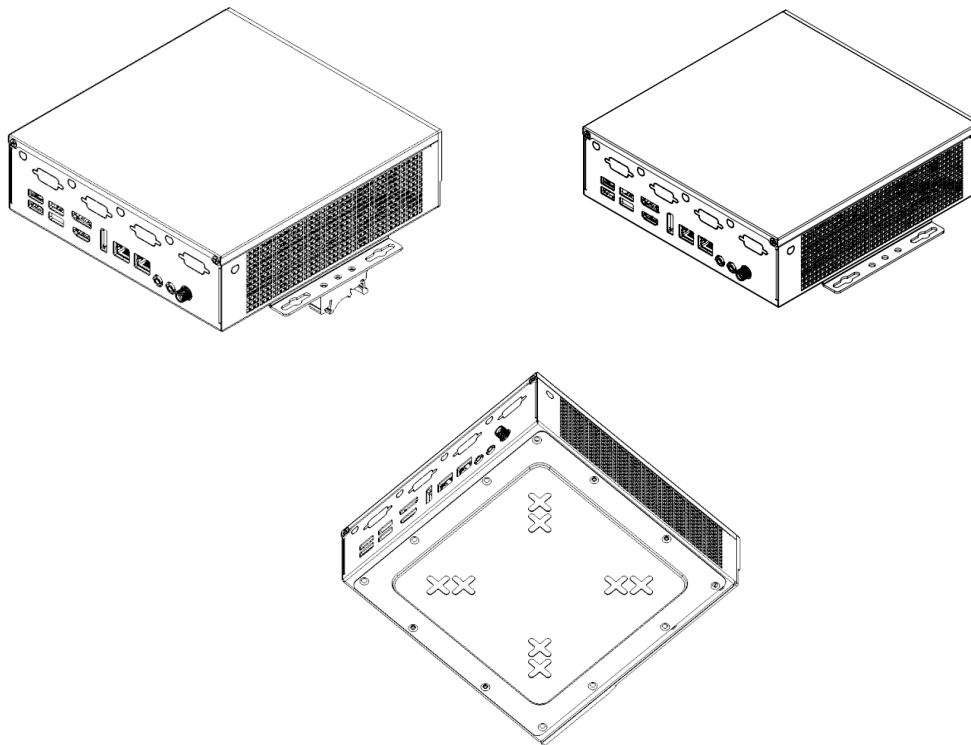

The MC510-55 and MC610-55 have optional Wall Mount brackets (SKU : MTW101 for the MC510-55, and MTW102 for the MC610-55) and DIN Rail mounting brackets (SKU : MTW101-K), and VESA Mounts (SKU: VMPL-1041 for the MC610-55, and VMP-1041 for the MC510-55) available for purchase.

#### **For Wall Mounting, follow steps below :**

**Step 1:** Align the four screw holes on the bottom of the system with the respective holes on the mounting brackets.

**Step 2:** Attach wall mounting brackets (MTW101) to the system using the supplied M3 screws (M3X0.5 Flathead Screw, 4mm Long). Use a torque of at least 18 in-lbs to attach brackets.

**Step 3 :** Install system to surface using keyhole slots on wall mount brackets and appropriate hardware for the surface (not provided).

#### **For DIN Rail Mounting, follow the below steps:**

**Step 1:** Follow steps 1-2 from the Wall Mounting section.

**Step 2:** Align the mounting holes of the din clip bracket to the three mounting holes on the wall mount bracket.

**Step 3:** Install the din clips to the wall mount brackets using supplied screws and a Phillips head screwdriver.

**Step 6:** Mount system onto the DIN rail.

*Note: The mounting brackets are required to support 3x the hanging weight of the system (14.82lbs / 6.72 kgs). The mating surface and hardware must be capable of supporting the same load.*

## 3.2 - VESA Mounting

The MC510-55 has an optional VESA mounting bracket (SKU : VMPL-2022-K) available for purchase. Follow the steps below for mounting.

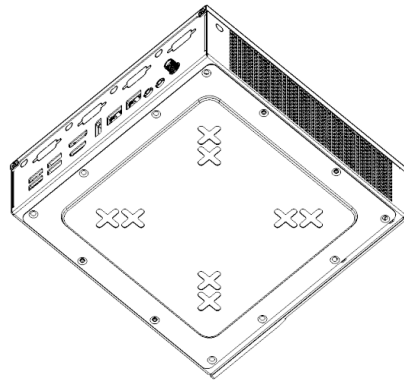

**Step 1:** Align the four screw holes on the bottom of the system with the respective holes on the mounting bracket.

**Step 2:** Attach VESA Mount Plate to the system using the supplied M3 screws (M3X0.5 Flathead Screw, 4mm Long) Use a torque of at least 18 in-lbs to attach brackets.

**Step 3:** Install the system to VESA 75 or VESA 100 mounting pattern using provided VESA Mount screws.

The mounting bracket systems are required to secure 3x the hanging weight of the computer system (14.82lbs / 6.72 kgs). The mating substrate must be capable of maintaining the same rating.

## 4 - Power Management

### 4.1 - Wake-Up Events

This platform supports multiple power states. The wake-up events can be configured in the BIOS. This section describes the supported power management functions and gives information on protection circuitry for power adapters.

Wake-Up Event	From ACPI State	Comments
Power Button	Deep S5, S5, S3	
LAN	S5, S3	Must be enabled in BIOS
USB	S3	
RTC Wake set by BIOS	Deep S5, S5	Must be enabled in BIOS
RTC Wake set by Linux	S3	Controlled by rtcwake command
RTC Wake set by Windows	s3	Controlled by task scheduler

### 4.2 - Protection Circuitry

Parameter	Value
Nominal operating voltage (Rated DC value of input)	12~24V
Undervoltage protection trip DC level (system turns off)	6.5V
Maximum safe DC voltage (system not damaged)	28.4V

These DC levels specified are the absolute max values for the pins for function and safety of the system. The protection circuitry allows for brief transient voltages above these levels without the system turning off or being damaged. A transient voltage suppressor on the power input allows momentary excursions above stated limits. For input power consumption and current see **Appendix A**.

## 5. Appendices

### 5.1 - Appendix A: Power

#### 5.1.1 - Average Power Consumption

The power consumption of the MC510-55 & MC610-55 was measured for various system configurations, workloads, and power states at both 12V and 24V system input voltages. Tests were performed using Prime 95, Furmark, and Burnintest v10 to stress system components. These tests were performed with Intel Turbo Boost Enabled. The build configurations and power consumption are listed in the tables below. The power consumption listed below is the **average** power draw over a 5 minute window from the test starting. The non-idle tests include a brief period of PL2 power consumption (previously Intel turbo Boost) where the power consumption is up to 71W more than the listed average.

\*The configurations below are using representative samples of internal devices, the specific components mentioned below may vary from the devices provided by OnLogic.

System Component	Config 1 Low (MC510-55)	Config 2 Medium (MC510-55)	Config 3 High (MC610-55)
CPU	Intel Celeron G6900E (Alder Lake) 3.0 GHz 2-Core Processor	Intel Core i9-13900TE Processor	Intel Core i9-13900TE Processor
Memory	1 x 4GB DDR4 SO-DIMM 2133MT/S Innodisk M4S0-4GSSNCRG	2 x 32GB DDR4 SO-DIMM 3200MT/S Transcend TS4GSH64V2E	2 x 32GB DDR4 SO-DIMM 3200MT/S Transcend TS4GSH64V2E
LAN	[1 port linked at full speed]	[2 ports linked at full speed]	[2 ports linked at full speed]
Storage #1 M.2 M-Key	Transcend MTE662T2 1TB Gen3 NVMe SSD	Transcend MTE662T2 1TB Gen3 NVMe SSD	Transcend MTE662T2 1TB Gen3 NVMe SSD
Additional Storage		2 x Transcend SSD470K 2TB 2.5" SSD	2 x Transcend SSD470K 2TB 2.5" SSD
M.2 B-Key		AMIT 4GLTE MDG200	AMIT 4GLTE MDG200
M.2 E key		Intel 9260NGW	Intel 9260NGW
Serial port		4xCOM	3xCOM
Expansion Port			NVidia RTX A4000 20GB GDDR6 ECC GPU

USB	Port 1: N/A Port 2: N/A Port 3: N/A Port 4: Mouse & Keyboard	Port 1: N/A Port 2: N/A Port 3: N/A Port 4: Wireless Mouse & Keyboard	Port 1: N/A Port 2: N/A Port 3: N/A Port 4: Wireless Mouse & Keyboard
Display	One Monitor	One Monitor	One Monitor
OS	Windows 11 Pro 64 Bit	Windows 11 Pro 64 Bit	Windows 11 Pro 64 Bit
OS Power Plan	Balanced	Balanced	Balanced
BIOS Version	1.30	1.30	1.30

The average power consumption for each system configuration is recorded below.  
See section "5.1.2 - Recommended Power Supply" for recommended power supplies

Low Config Measurements		
Power Consumption	12V Avg [W]	24V Avg [W]
Deep S5	0.8	2.8
S5	2	5
S3	2.3	5.4
OS Idle	21.4	24.1
CPU / System stress	32.7	25.5
CPU + GPU / System stress	38.2	40.2
Medium Config Measurements		
Power Consumption	12V Avg [W]	24V Avg [W]
Deep S5	0.9	3
S5	3.6	7.4
S3	3.8	7.8
OS Idle	30.1	33.9
CPU / System stress	68.2	70.7
CPU + GPU / System stress	70.3	71.9
High Config Measurements		
Power Consumption	12V Avg [W]	24V Avg [W]
Deep S5	N/A	3.3
S5	N/A	5.8
S3	N/A	6.8
OS Idle	N/A	48
CPU / System stress	N/A	82.8
CPU + GPU / System stress	N/A	159.3

## 5.1.2 - Recommended Power Supply

### MC610-55

The MC610-55 is sold with a 330W power supply

### MC510-55

This recommendation takes into account the maximum peak power usage of each component, along with an additional overhead for safety. The optimal approach for determining the appropriate power supply size involves precise measurements using the actual hardware and specific applications.

			RAM			
			4GB / 8GB	16GB	32GB	64GB
CPU	Turbo*	G6900E	120W	120W	230W	230W
		i3-13100TE	230W	230W	230W	230W
		i3-12100TE	230W	230W	230W	230W
		i5-13500TE	230W	230W	230W	230W
		i7-13700TE / i9-13900TE	230W	230W	230W	230W
	Turbo disabled	G6900E	120W	120W	230W	230W
		i3-13100TE	100W**	120W	120W	230W
		i3-12100TE	100W**	120W	120W	230W
		i5-13500TE	100W**	120W	120W	230W
		i7-13700TE / i9-13900TE	100W**	120W	120W	230W

\*Turbo comes default in all systems unless modified in the BIOS

\*\*100W PSU may not be possible when built with max drive config

## 5.3 - Appendix B: BIOS manual and Drivers

For a detailed overview of the BIOS screens and individual settings, as well as instructions for updating the BIOS, please refer to the ASRock IMB-1232 manual section 3 at the link below.

<https://download.asrock.com/IPC/Manual/IMB-1232-WV.pdf>



## 5.4 - Appendix C: System Thermal Results

### 5.4.1 Test Conditions

- Temperature Range: 0°C to 50°C
- Step size: 10°C
- i9-13900TE Processor loaded with Intel XTU
- SSD, DDR4 RAM, and A4000 SFF GPU loaded @ 80% with BurnInTest 10.1

### 5.4.2 Test Methodology

Thermal testing of the MC510-55 and MC610-55 was completed using a thermal chamber to control ambient environmental temperature across the rated temperature range of the system. Throughout testing, the system and its components were being stressed by various softwares to simulate a rigorous constant workload. Stress testing occurred for two hours in each temperature range. Components were monitored during testing via their internal sensors. Some components, and ambient air were monitored externally via thermocouples.

### 5.4.3 Test Results

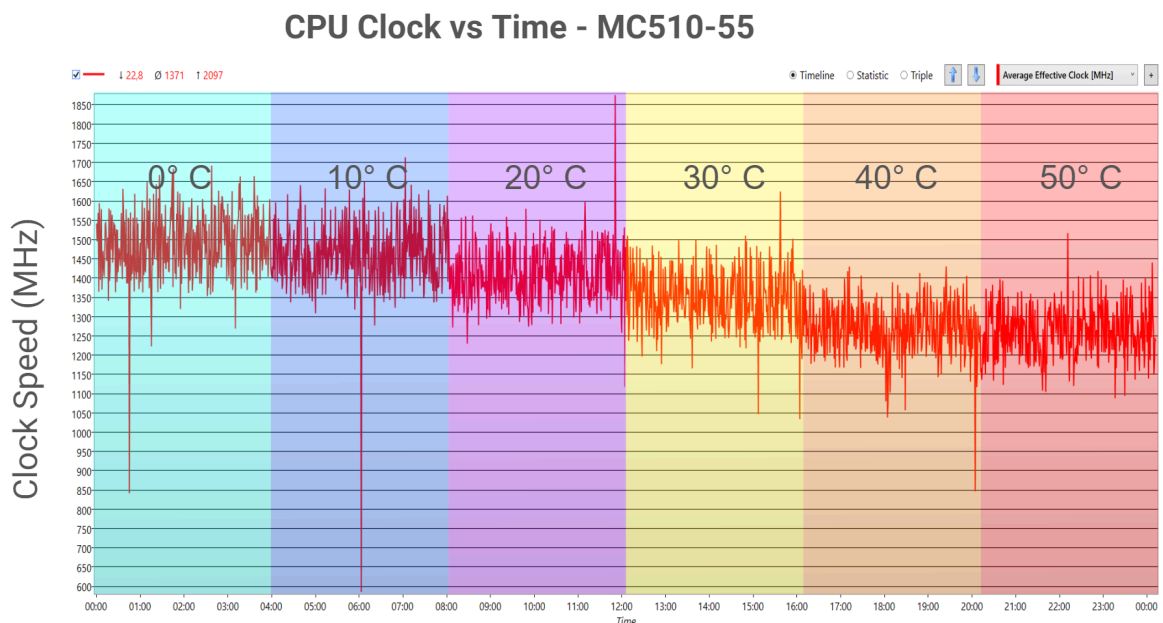

### CPU Temperature vs Time - MC510-55

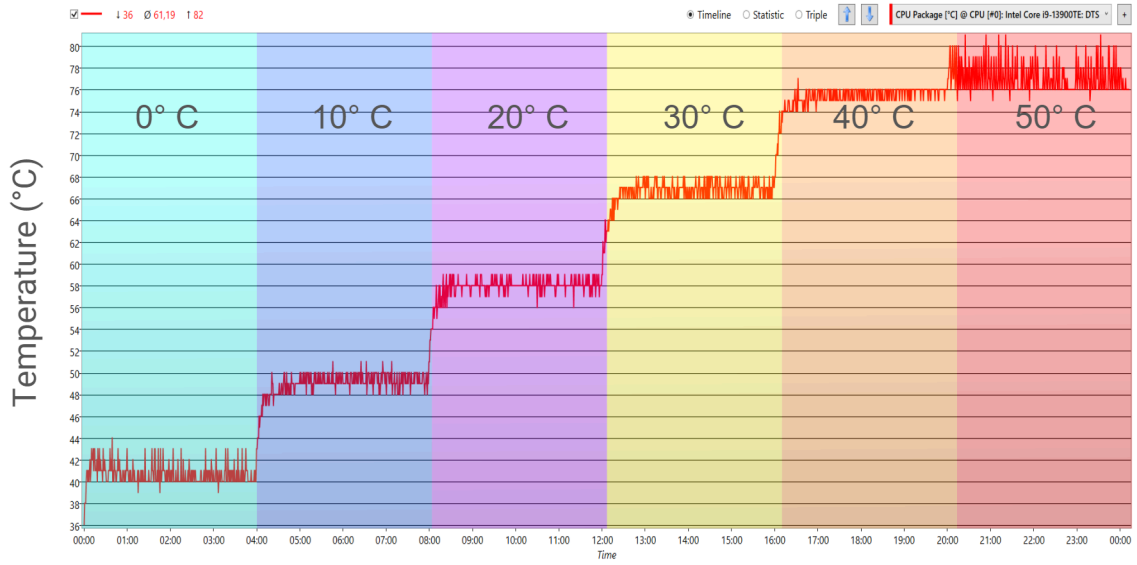

### CPU Clock vs Time - MC610-55

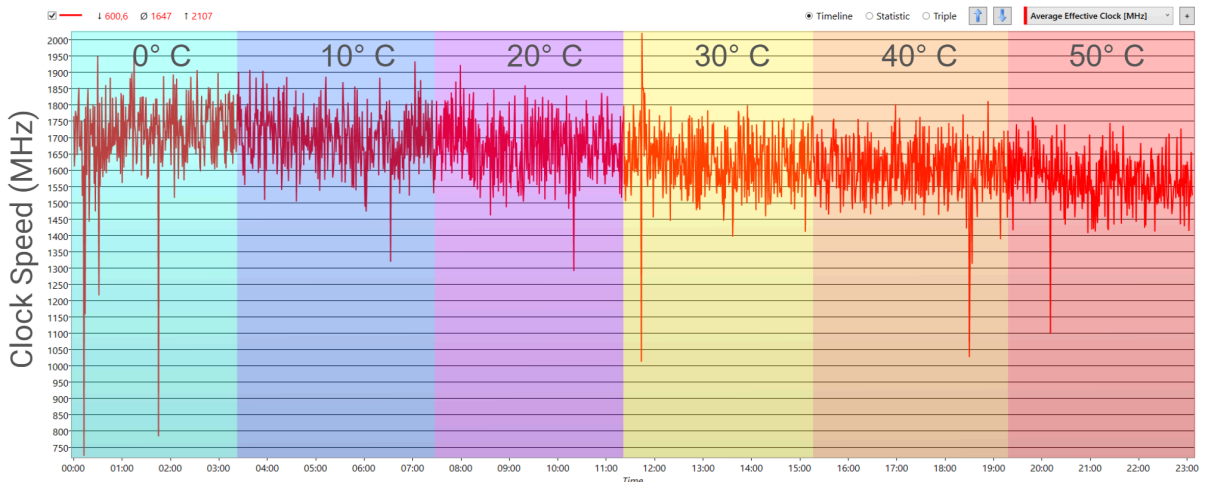

## CPU Temperature vs Time - MC610-55

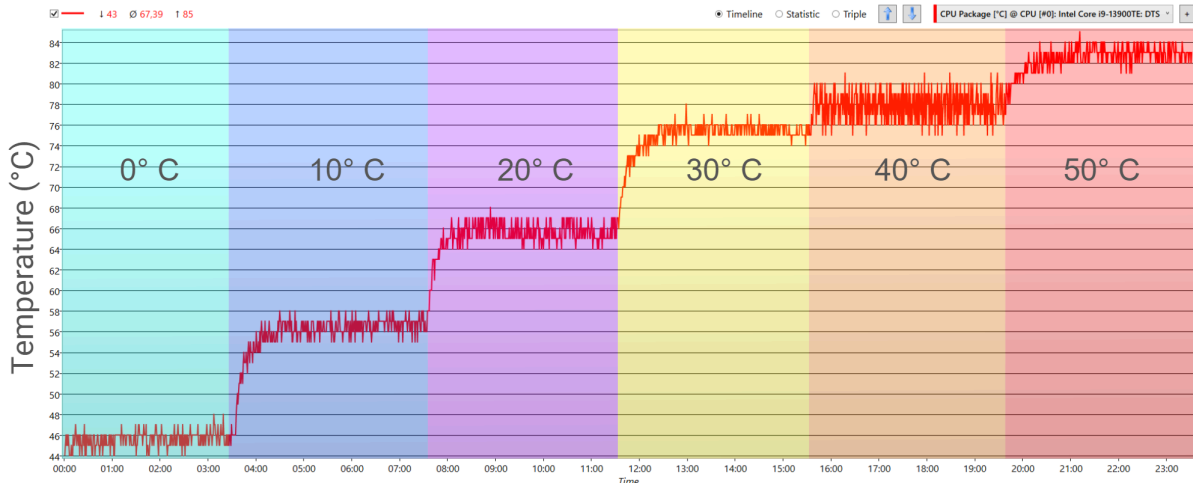

### 5.4.4 Test Result Summary

The MC510-55 with the i9-13900TE sustained significant processor, memory, and storage loads through a temperature range of 0-50°C without any significant performance drop in either performance or efficiency core clock speed. Neither the efficiency nor performance clocks dip below their rated base clock.

The MC610-55 with the i9-13900TE sustained significant processor, memory, and storage loads through a temperature range of 0-50°C without any significant performance drop in either performance or efficiency core clock speed. Clock speeds remained saturated upwards of each core type's respective rated base clocks.

## 5.5 Appendix E: Regulatory Compliance

### 5.5.1 CE

The computer system was evaluated for medical, IT equipment. The computer complies with the relevant IT equipment directives for the CE mark. Modification of the system may void the certifications. Testing includes: EN 55032, EN 55035, IEC 60601-1 and EN 62368-1. Product safety was evaluated to IEC 62368-1.

### 5.5.2 FCC Statement

This device complies with part 15 of the FCC rules as a Class A device. Operation is subject to the following two conditions: (1) this device may not cause harmful interference and (2) this device must accept any interference received, including interference that may cause undesired operation.

### 5.5.3 ISED

This device complies with Industry Canada license-exempt RSS standard(s). Operation is subject to the following two conditions: (1) this device may not cause interference, and (2) this device must accept any interference, including interference that may cause undesired operation of the device.

Le présent appareil est conforme aux CNR d'Industrie Canada applicables aux appareils radio exempts de licence. L'exploitation est autorisée aux deux conditions suivantes: (1) l'appareil ne doit pas produire de brouillage, et (2) l'utilisateur de l'appareil doit accepter tout brouillage radioélectrique subi, même si le brouillage est susceptible d'en compromettre le fonctionnement.

**CAN ICES-003(A) / NMB-003(A)**

### 5.5.4 UKCA

The computer system was evaluated for medical, IT equipment, automotive, maritime and railway EMC standards as a class A device. The computer complies with the relevant IT equipment directives for the UKCA mark.

### 5.5.5 VCCI

This is a Class A product based on the standard of the Voluntary Control Council for Interference (VCCI). If this equipment is used in a domestic environment, radio interference may occur, in which case the user may be required to take corrective actions.

この装置は、クラス A 情報技術装置です。この装置を家庭環境で使用すると電波妨害を引き起こすことがあります。この場合には使用者が適切な対策を講ずるよう要求されることがあります。 VCCI-A

## 5.6 Appendix F: Safety Precautions, Safeguards & Information

**Do not open and modify the device! The device complies with various national and international Safety, EMC and Environmental requirements per various standards.**

**Modification of the device may void certifications, warranty and/or cause possible injury to the user.**

### 5.6.1 Safe use and installation instructions

1. Care must be taken handling the device to prevent injury to self or possibility of damaging the unit.
2. Read the entire manual before using the product.
3. Install the device securely per users manual instructions.
4. To protect against excessive RF exposure, maintain at least 20cm from any user and the RF antennas. Only use provided dual band antennas of 2dBi/2dBi gain.
5. Wall or ceiling mounting device requires use of OnLogic mounting plate or bracket.
6. Use M3x0.5mm Flat Head screws to attach mounting plate or mounting brackets to threaded holes on bottom of chassis. Screws should be a minimum length of 4mm. Add 1mm of screw



length for every mm of additional thickness of plate or bracket beyond 1.5mm.

7. **Caution, Hot Surface!** It is normal for the unit to heat up and be hot to touch. **Do not touch** the heatsink area or enclosure during operation and 30 minutes after shutdown allowing the unit to cool down.
8. Ambient operating temperature must be between 0 °C to 40 °C with a non-condensing relative humidity of 10-85%.
9. The device can be stored at temperatures between -10 °C to 85 °C. Note: Unit must be stabilized within operating temperature before use, minimum 3HR.
10. Keep the device away from liquids and flammable materials. Not to be installed in a hazardous environment.
11. Do not clean the device with liquids. The chassis can be cleaned with a dry cloth or duster only. To prevent injury to self and/or damage to the device the unit must be powered down and all connecting power and other peripherals shall be disconnected prior to cleaning.
12. Allow adequate space around all sides of the device for proper cooling and to not exceed its maximum operating temperature limit. If the device is mounted to a vertical surface then recommended device orientation is such that heatsink fins allow air to rise unobstructed. Alternative orientations may result in reduced operational temperature range.
13. This device is intended for indoor operation only.
14. **Caution, Risk of Electric Shock!** Unit is powered by low voltage DC (Direct Current) only! Do not connect AC (Alternating Current) into the device!
15. To power the device use only UL ITE Listed external power supplies with DC output of 12-24VDC, see specs for details.
16. Wiring methods used for the connection of the equipment to the mains supply shall be in accordance with the National Electrical Code, NFPA 70, and the Canadian Electrical Code, Part I, CSA C22.1.
17. Allow ample space for terminal block wiring connections such that the wires do not bend and are protected from accidental damage.
18. Install the device only with shielded network cables.
19. The installer should be experienced in aftermarket installation and familiar with general practices for installing electronics.
20. Radio device is not intended for emergency service use.
21. Service and repair of the device must be done by qualified service personnel. This includes, but is not limited to, replacement of the CMOS battery. Replacement CMOS battery must be of the same type as the original.
22. Proper disposal of CMOS battery must comply with local governance.
23. Product must only be connected to a certified router, switch or similar network equipment
24. Product is intended for indoor use only.
25. Product cannot be connected to the public network.
26. This equipment is not suitable for use in locations where children are likely to be present.





**WARNING:** There is danger of explosion if the CMOS battery is replaced incorrectly. Disposal of battery into fire or a hot oven, or mechanically crushing or cutting of a battery can result in an explosion.

## 5.6.2 Précautions et guide d'installation

**Ne pas ouvrir et modifier l'appareil ! L'appareil est conforme à diverses exigences nationales et internationales en matière de sécurité, de CEM et d'environnement selon diverses normes.**

La modification de l'appareil peut annuler les certifications, la garantie et/ou causer des blessures à l'utilisateur.

1. Des précautions doivent être prises lors de la manipulation de l'appareil pour éviter de se blesser ou d'endommager l'appareil.
2. Lisez l'intégralité du manuel avant d'utiliser le produit.
3. Installez l'appareil en toute sécurité selon les instructions du manuel de l'utilisateur.
4. Pour vous protéger contre une exposition RF excessive, maintenez au moins 20 cm de tout utilisateur et des antennes RF. Utilisez uniquement les antennes double bande fournies avec un gain de 2 dBi/2 dBi.
5. Le dispositif de montage mural ou au plafond nécessite l'utilisation d'une plaque ou d'un support de montage. La plaque ou le support doit être en métal et avoir une épaisseur minimale de 1 mm.
6. Utilisez des vis à tête plate M4x0,5 mm pour fixer la plaque de montage ou les supports de montage aux trous filetés au bas ou à l'arrière du châssis. Les vis doivent avoir une longueur minimale de 4 mm. Ajoutez 1 mm de longueur de vis pour chaque mm d'épaisseur supplémentaire de plaque ou de support au-delà de 1,5 mm.
-  7. **Attention surface chaude!** Il est normal que l'appareil chauffe et soit chaud au toucher. Ne touchez pas la zone du dissipateur thermique ou le boîtier pendant le fonctionnement et 30 minutes après l'arrêt pour permettre à l'unité de refroidir.
8. La température ambiante de fonctionnement doit être comprise entre 0 °C et 40 °C avec une humidité relative sans condensation de 10 à 85 %.
9. L'appareil peut être stocké à des températures comprises entre -10 °C et 85 °C. Remarque : L'unité doit être stabilisée à la température de fonctionnement avant utilisation, minimum 3 heures.
10. Gardez l'appareil à l'écart des liquides et des matériaux inflammables. Ne pas installer dans un environnement dangereux.
11. Ne nettoyez pas l'appareil avec des liquides. Le châssis peut être nettoyé uniquement avec un chiffon sec ou un plumeau. Pour éviter de se blesser et/ou d'endommager l'appareil, l'appareil doit être éteint et toutes les alimentations et autres périphériques doivent être déconnectés avant le nettoyage.
12. Prévoyez un espace suffisant autour de tous les côtés de l'appareil pour un refroidissement correct et pour ne pas dépasser sa limite de température de fonctionnement maximale. Si l'appareil est monté sur une surface verticale, l'orientation recommandée de l'appareil est telle que les ailettes du dissipateur thermique permettent à l'air de monter sans obstruction. Des orientations alternatives peuvent entraîner une plage de températures de fonctionnement réduite.
-  13. Cet appareil est destiné à une utilisation en intérieur uniquement.
14. **Attention, risque de choc électrique !** L'unité est alimentée uniquement par une basse tension CC (courant continu) ! Ne connectez pas le courant alternatif (courant alternatif) à l'appareil !
15. Pour alimenter l'appareil, utilisez uniquement des alimentations externes répertoriées UL ITE avec une sortie CC de 12-24 VCC, voir les spécifications pour plus de détails.
16. Les méthodes de câblage utilisées pour le raccordement de l'équipement à l'alimentation secteur doivent être conformes au Code national de l'électricité, NFPA 70, et au Code canadien de l'électricité, Partie I, CSA C22.1.
17. Prévoyez suffisamment d'espace pour les connexions de câblage du bornier afin que les fils ne se plient pas et soient protégés contre les dommages accidentels.
18. Installez l'appareil uniquement avec des câbles réseau blindés.
19. L'installateur doit avoir de l'expérience dans l'installation de pièces de rechange et être familiarisé avec les pratiques générales d'installation de composants électroniques.
20. L'appareil radio n'est pas destiné aux services d'urgence.
21. L'entretien et la réparation de l'appareil doivent être effectués par un personnel qualifié. Cela inclut, mais sans s'y limiter, le remplacement de la batterie CMOS. La batterie CMOS de remplacement doit être du même type que celle d'origine.
22. L'élimination appropriée de la batterie CMOS doit être conforme à la gouvernance locale.
23. Le produit doit uniquement être connecté à un routeur, un commutateur ou un équipement

réseau similaire certifié

24. Le produit est destiné à une utilisation en intérieur uniquement.
25. Le produit ne peut pas être connecté au réseau public.
26. Cet équipement n'est pas adapté à une utilisation dans des endroits où des enfants sont susceptibles d'être présents.



**ATTENTION:** Il existe un risque d'explosion si la pile CMOS n'est pas remplacée correctement. L'élimination de la batterie dans le feu ou dans un four chaud, ou l'écrasement ou le découpage mécanique d'une batterie peut entraîner une explosion.

## 5.7 Appendix G: Errata

The MC610-55 only supports a standard 900mA regulated 5V output to power USB3 devices via each port on the PCIe-USB381F Neosys 8-Port USB 3.1 Gen1 Frame Grabber.